

Geda Paulsen

# Causation and Dominance

A study of Finnish Causative Verbs  
Expressing Social Dominance





## **Geda Paulsen**

Born 1973 in Valga, Estonia

M.A. Åbo Akademi University, Finland, 2004

Doctoral student, Åbo Akademi University, Finland

Cover: Tove Ahlbäck

Photo: Helga Paulsen

Åbo Akademi University Press  
Biskopsgatan 13, FI-20500 ÅBO, Finland  
Tel. int. +358-20-786-1468  
E-mail: [forlaget@abo.fi](mailto:forlaget@abo.fi)  
<http://www.abo.fi/stiftelsen/forlag/>

Distribution: Oy Tibo-Trading Ab  
P.O.Box 33, FI-21601 PARGAS, Finland  
Tel. int. +358-2-454 9200  
Fax int. +358-2-454 9220  
E-mail: [tibo@tibo.net](mailto:tibo@tibo.net)  
<http://www.tibo.net>



## CAUSATION AND DOMINANCE



# Causation and Dominance

A Study of Finnish Causative Verbs  
Expressing Social Dominance

Geda Paulsen

ÅBO 2011

---

ÅBO AKADEMIS FÖRLAG – ÅBO AKADEMI UNIVERSITY PRESS

**CIP Cataloguing in Publication**

**Paulsen, Geda.**

Causation and dominance : a study of  
Finnish causative verbs expressing  
social dominance / Geda Paulsen. -  
Åbo : Åbo Akademi University Press,  
2011.

Diss.: Åbo Akademi University.

ISBN 978-951-765-556-9

ISBN 978-951-765-556-9  
ISBN 978-951-765-557-6 (digital)  
Oy Nord Print Ab  
Helsingfors 2011

*To Helga and Hugo*





# Contents

<b>Acknowledgments</b>	<b>9</b>
<b>1 Introduction</b>	<b>11</b>
1.1 Topic and aims	11
1.2 Defining a derivational group – causative verbs of social dominance in the twilight zone between grammar and lexicon	15
<b>2 Theory and methods</b>	<b>30</b>
2.1 Theoretical background: conceptual semantics	30
2.2 Basic tools of conceptual semantics	39
2.2.1 Tiers and zones in the conceptual structure	39
2.2.2. Linking of syntactic, semantic and morphological arguments	47
2.2.3 Architecture of the tiernet model	52
2.3 Material and methods	56
2.3.1 Structured vs. non-structured language corpora	56
2.3.2 Verbs selected for examination	65
2.4 Prototypes and the lexical analysis	73
2.4.1 Classical and prototype-based categorization	73
2.4.2 Defining CSD prototypes	76
2.5 Causation and transitivity	80
<b>3 Syntactico-lexical linking and the argument structure of CSDs</b>	<b>89</b>
3.1 Syntactic analysis. The transitivity effect of the root verb on derivatives	90
3.1.1 Discussion of the Finnish object	90
3.1.2 Aessive adjunct and argument fusion	93
3.1.3 Test of the syntactic behaviour of CSDs	95
3.1.4 Language instinct test	104
3.1.4.1 Results of <i>ompeluttaa</i> ‘make s.o. sew’	109
3.1.4.2 Results of <i>syötättää</i> ‘make s.o. eat’	114
3.1.4.3 Results of <i>jonotuttaa</i> ‘make s.o. queue’	121
3.1.4.4 Language instinct test summarized	127
3.2 Linking from LCS to syntactic arguments	136
3.3 Lexical conceptual analysis of test verbs	139
3.3.1 High transitivity verbs	140
3.3.2 Medium transitivity verbs	148
3.3.3 Low transitivity verbs	156
3.4 Towards a prototype-constructional approach	164
3.5 Diversity of argument structure: the case of <i>leikittää</i> ‘make s.o. play’	170
3.6 Conclusions on linking regularities and syntax-semantic interface of CSDs	174
<b>4 Causation, agentivity and temporal relations</b>	<b>178</b>
4.1 Activity and dominance	178
4.1.1 Structure of the action tier	179

4.1.2 Action tier configurations of CSDs with causative vs. non-causative roots	182
4.2 Agent features and their distribution between CSD arguments	189
4.3 Temporal and causal relations of CSDs	195
4.3.1 Temporal tier and causation events	196
4.3.2 Temporal structure of double-causative prototype verbs	198
4.3.3 Temporal structure of single-causative prototype verbs	203
4.3.4 Ambiguity in interpretation of argument structure	206
4.3.5 Causative subordinate structures and effect on core sentence	212
4.3.6 The verbs <i>tapattaa</i> [kill-caus] and <i>itkettää</i> [cry-caus]	215
4.4 Conclusions on interplay of causation, activity and temporal structure	222
<b>5 CSDs and constructions</b>	<b>224</b>
5.1 Social conceptualization as a source for construction building	224
5.2 Power Misuse Construction and ‘bossy’ causatives	227
5.2.1 CSDs with motion verbs as root: the case of <i>juoksuttaa</i> ‘make s.o. run’	227
5.2.2 Strong and weak PMC: modifications of the Power Misuse Construction	233
5.2.3 Power abuse and different types of motion	237
5.2.4 CSDs other than causatives derived from motion verbs adapting the Power Misuse Construction	241
5.2.4.1 Power and competition	245
5.2.4.2 <i>Kyykyttää</i> ‘make s.o. squat’ and the semantic network	250
5.2.5 Associative binding within PMC subconstructions	262
5.2.6 Power Misuse Construction and interpretation constructions	266
5.3 Other constructions with social implications	274
5.3.1 Responsibility Shift Construction	275
5.3.2 Aspects of responsibility: the responsible SAR and psychosocial causers	286
5.3.3 A lexical particularity: <i>tapattaa</i> ‘make s.o. kill’ and the responsible SAD	292
5.3.4 A verb applying several causative constructions: the case of <i>haetuttaa</i> ‘make s.o. fetch’	294
5.4 Discussion of CSD constructions	303
5.4.1 Constructions and the salient properties of CSDs	313
5.4.2 CSDs and Internet genres	329
<b>6. Conclusion</b>	<b>345</b>
<b>Svensk sammanfattning</b>	<b>366</b>
<b>References</b>	<b>368</b>
<b>Abbreviations and symbols</b>	<b>377</b>
<b>Appendix 1</b>	<b>379</b>

## Acknowledgments

It is a pleasure to thank the people and institutions that made the completion of this thesis possible. First of all, I am heartily grateful to my supervisor, Professor Urpo Nikanne at the Department of Finnish language at Åbo Akademi University for his patience, encouragement and intellectual inspiration during the research process as well as for his support in the process of seeking funding.

This PhD project was carried out at Åbo Akademi University from 2004-2010. I am fortunate to have had the support of the colleagues at the Department of Finnish language. Thank you for the pleasant coffee-table meetings and good advice, Eeva Lähdemäki, Juhani Löflund, Leena Maria Heikkola, Katarzyna Wojciechowicz, Oksana Petrova and Arja Lehtonen. My special thanks go to the Department secretary Arja for helping with practical issues and for keeping asking about the progress of the thesis. I also thank Anne Holmberg at the Faculty of Arts and Inger Hassel at Åbo Akademi Foundation Research Institute and Åbo Akademi University Press for their friendly help with the practical matters. The research room colleagues have been a pleasant companion on the journey, a special thanks to Sandra Uitto for her friendship and optimism.

I would like to thank the reviewers of this thesis, Professor Mila Vulchanova and Associate Professor Ilona Tragel for their careful inspection and constructive criticism on the manuscript.

The acknowledgment for my research topic goes to Docent Leena Kytömäki at the Department of Finnish Language at Turku University and her inspiring research on Finnish derivation system. A special thanks to Professor Emeritus in Baltic-Finnic languages Tiit-Rein Viitso at Tartu University, for drawing my attention to Kytömäki's work and awakening curiosity for the causative derivation in Finnish.

This thesis would not have been possible unless the financial support. I am grateful for the opportunity to be a part for the research project Motion Encoding in Language funded by the Nordic Research Council. During my PhD studies I have been privileged to be a member of the Finnish Graduate School in Language Studies, Langnet that in addition to providing excellent scientific courses and the opportunity to make connections with talented researchers within the field of linguistics in Finland also supported my research financially for a year. I also wish to show my gratitude to the Research Institute of the Åbo Akademi Foundation and the Finnish Cultural Foundation for funding parts of my research project.

This study has benefited from stimulating discussions at the research seminars at Åbo Akademi University, Turku University, numerous conferences and the courses and seminars at the Finnish Graduate School in Language Studies, Langnet. I have especially enjoyed the inspiring and warm

atmosphere of the linguistic research seminar Spremi at Åbo Akademi, created by Professor Tuija Virtanen-Ulfhielm, Professor Erik Andersson, Professor Urpo Nikanne and all the participants whose names it is not possible to mention here. I would like to thank Yrsa Neuman, Olli Lagerspetz and all the other participants in seminars on the Philosophy of the Human Sciences for rewarding discussions about the nature of linguistic theories. The meetings and seminars of the excellent research group Motion Encoding in Language have been most stimulating; thanks to the members of this project. A special thank to Crystal Walker for her kind friendship and for a rewarding teamwork.

I am grateful to Hanna Jokela at the Turku University for her invaluable friendship and her kind assistance with the completion of the language instinct test. I also want to thank the students of the Open University of the University of Turku who participated in the experiment. Thanks to Greg Dunn for the throughout language check of my manuscript, Tuija Virtanen-Ulfhielm for reading and commenting (horrible) early parts of my thesis, Leena Maria Heikkola for helping to polish some of the most impossible and colourful language examples into English and Juhani Löflund for correcting the abstract in Swedish.

Finally, I would like to express my warmest gratitude to my parents Olev and Helle for their encouragement and care, even though they have had a very vague idea of what I have been up to all these years. Thanks to Helin, Aveli and Katre for the sisterhood, a special thank to my little sister Katre for her aid with layout tricks. I am indebted to my dear children Hugo and Helga for being patient during the writing process and for reminding me of the other aspects in life than research and writing. I also want to express my appreciation for Ahto who has helped me with numerous technical problems and my language example translations to English, but most of all has been there for me.

Tartu, 28.12.2010

Geda Paulsen

# 1 Introduction

## 1.1 Topic and aims

The subject of this study is the concept of causation, with emphasis on causation events that include two active animate participants. As the linguistic basis I use a group of Finnish morphological causative verbs<sup>1</sup>. Deriving causative verbs using the suffixes *ttA* and *UttA* is a productive morphological process in Finnish, and the number of verbs from which a causative can be formed is large (we will return to a more detailed analysis of these derivative suffixes in section 1.2 below). Using this morpheme, the causatives can be formed from verbs (*huudattaa* [scream-cause], *juokuttaa* [run-cause], *taivuttaa* [bend-cause]), nouns (*kivittää* [stone-cause], *puolittaa* [half-cause]) and even from other words (*ohittaa* [past-cause], *pystyttää* [upright-cause]). Deverbal causative derivatives encoding two active, typically human, arguments are identified in Finnish grammatical tradition as *kuratiivikausatiivit* ‘curative causatives’. Examples using the morphological causative verbs *maalauttaa* ‘make s.o. paint’ and *laulattaa* ‘make s.o. sing’ are presented in (1) and (2) below:

- (1) *Maija maalauttaa Matilla talon*  
 Maija paint-caus-pres-3sg Matti-ade house-acc  
 ‘Maija makes Matti paint a/the house’
- (2) *Opettaja laulattaa lapsia kuorossa*  
 teacher sing-caus-pres-3sg child-pl-part choir-ine  
 ‘The teacher makes the children sing in the choir’

The definitions of the curative causative derivative group are based on two types of criteria: morphosyntactic and semantic. The first requirement is adopted, for instance, in the latest reference grammar of Finnish, *Iso suomen kielioppi* ‘A Comprehensive Finnish Grammar’ (Hakulinen et al. 2004, hereafter ‘ISK’), solely classifying derivatives with transitive root verbs as curative causatives. According to this view, sentence (1) is a curative causative, but not (2). Kytömäki (1978) on the other hand does not see transitivity as the significant factor in semantic analysis of causative verbs

---

<sup>1</sup>Finnish is a Finno-Ugrian language belonging to the Uralic languages, with the Baltic-Finnic languages (Karelian, Estonian, Lude, Veps, Vote and Livonian) as closest relatives. It is characterised by a rich case system and also a highly inflected verb system. A prominent distinctive feature of Finnish is its derivative system which typically for the Finno-Ugric languages almost completely operates by means of suffixication (see for instance Kangasmaa-Minn 1994).

and emphasizes that semantic criteria should be also considered in verb classification. In this case, sentence (2) can also be classified as a curative causative.

In my study, I aim to consider the traditional criteria used to define curative causatives and the implications of diverse criteria on the derivative verb system. The starting point will be the question of the nature of the curative causative verb group and how homogeneous it is. I will argue that the definition based on the morphological form and transitivity is not sufficient in a comprehensive account of these verbs. Like underived verbs, derivative verbs are a rather complex phenomenon, which should be taken into account in the description of language. My estimation is that the range of variation in the specified meaning of these derivatives as well as in their semantic relation to roots suggests that they have an individual lexical formation. An observation based on the corpus analysis of these verbs is that the semantic interpretation of these causatives is sensitive to context, and meanings vary largely. Because my aim is to approach the subject on its own premises and also to consider the gaps in the paradigm of curative causatives, I will use instead the term *causatives of social dominance* (hereafter **CSDs**) when talking about the verbs I am studying. Another reason for the redefinition is the focus in this study, the concept of causation with emphasis on the causation event with typically two active, human participants – the limits of what are called ‘curative causatives’ would be too restrictive and leave out many phenomena related to the same concept.

What is the lexical knowledge associated with CSDs? This question leads to the problem of what the rule-based or common information unifying the verb group is exactly and what can be regarded as idiosyncratic information. In my analysis of the lexical conceptual structure (lexical semantics) of CSDs I use the theory of conceptual semantics, based in particular on the work of Jackendoff (1983, 1990), Nikanne (1990, 1995, 1997) and Pörn (2004). Formal analysis of the lexical conceptual structure enables a systematic description of the phenomena relevant to CSDs, such as causation, agentivity, dominance, temporal relations and the mapping relationships between syntax and semantics. The conceptual semantics description is supported by an investigation of the use of CSDs in the text corpus Kielipankki ‘Language bank’ and a corpus collected from texts on the Internet. The online material is necessary because some of these verbs are not found frequently enough in standard corpora, whereas on the Internet there are plenty of examples from e.g. particular interest groups or sub-standard styles. In this way it is possible to obtain information about CSDs in textual and situational contexts. Another source for generalizations is the results of the language instinct test of selected CSDs derived from varied types of root verbs in respect to their transitivity values, situated in six different sentential contexts.

The systematic description, on the one hand, and actual language use, on the other, also allow an investigation of the constructions that occur in

association with CSDs. One example of construction-building is causatives with a motion verb as their root, like *juoksuttaa* ‘make s.o. run’ and *hyppyttää* ‘make s.o. jump’, verbs with a lexicalized power relation: the higher agent (the one that makes the other run or jump) is misusing his/her power over the lower agent (the one that runs or jumps). An example of this kind of power relation would be (3):

- (3) *Napero juoksuttaa vanhempiaan.*  
 kid run-caus-pres-3sg parent-pl-part-px3sg  
 ‘The kid is making his parents run around’

The formal approach has to take into account not only the causation and the lexical structure of the CSDs but also the social implications that are strongly present in the meaning. The description of these verbs must include information on context that triggers the special readings of social relations, such as e.g. the negative social dominance. These constructions have a strong connection to the speaker’s voice, expressing an affective attitude to the situation, which must also be included in the description. One goal of this study is to detect and describe the contexts that activate the interpretation of special nuances in social conception and, eventually, how social relations are coded in verb and construction meanings. The social implications related to CSDs will be a challenge for the formal analysis in this study.

Another example of constructions associated with CSDs is the verb *tapattaa* ‘to have someone killed’, a verb whose argument structure does not completely correspond to a prototypical CSD. This verb occurs in a construction consisting of the object of the verb and a PP or adverb that expresses location, as in (4). It is noticeable that the general is not making anyone kill the soldiers, as it is probably the enemy that is doing this, and the general has not asked or forced the enemy to do so. However, the general is held *responsible* of the death of his soldiers – he made the wrong decision or simply did not care. The location phrase, ‘on the front’, expresses the causing event and refers to the place and circumstances in which the soldiers were killed. In my thesis, I search for optimal ways to formally describe such complex argument structure.

- (4) *Kenraali tapatti sotilaitaan rintamalla*  
 general run-caus-past-3sg soldier-pl-part-px3sg front-ade  
 ‘The general let his soldiers be killed on the front’

The course of this study goes from formal analysis of the lexical structure of CSDs to language usage and the behaviour of these verbs in use. Using the conceptual semantics theory in the investigation of derivatives is designed to achieve an integrated language description that takes account of syntactic, semantic and pragmatic information on the research subject in an explicit



way. The theoretical contemplation throughout this study seeks to find an explanation to the questions: How does the word formation system function in light of the complex phenomenon CSDs display? What is the easiest way of describing context-dependent relations? Do we need clear-cut or gradual methodological tools? I suggest a division between changeable and fixed semantic features in the lexical description of these derivatives. For this, I combine different types of linguistic categories: classical and prototype-based. I aim to develop the idea of a prototype semantic interpretation for these derivatives. My hypothesis is that the prototype structure can be used to reveal constructional extension and idiosyncrasy. I also discuss the interaction between CSDs and context. Hence, besides constructed sentences, language use material will be present throughout the study.

I begin the analysis with a more thorough discussion of the definitions of curative causatives in section 1.2. The theoretical background and methodology of this study, the conceptual semantics approach, is presented in chapter 2 (see sections 2.1-2.2). This is followed by a closer explanation of the material of this study, which is given in section 2.3. This chapter also involves a discussion of the linguistic categories worked with in this study (in section 2.4) as well as of concepts important for CSDs: transitivity and causation (2.5). The preliminary description of the prototype structures of CSDs is given in section 2.4.2. In chapter 3, I concentrate on the syntactic transitivity-based behaviour of the CSDs. The syntactic analysis is based on two tests: a syntactic test of six selected CSDs with different transitivity value altered in different sentence types (3.1.3) and a language instinct assessment of three verbs from the syntactic test tested on native language users (3.1.4). The results of this analysis are mirrored in the prototype structures as defined in chapter 2. The basis for this is the linking relation analysis between the conceptual and syntactic structure of the tested verbs in section 3.3. As a result, the prototype structures are analysed again in 3.4. Chapters 4 and 5 further discuss the argument structure and semantic properties of CSDs. The semantic features related to the notion of agentivity in relation to CSD arguments and the temporal effect on causation events are the main topics of chapter 4. The idiosyncratic phenomena connected with CSDs, CSD constructions, are discussed in chapter 5; the language use material is in focus here. The authentic language use examples are also an important tool in the analysis of the agent features of CSD arguments and relationships between the causing and caused event (in chapter 4) as well as in the variable argument structure analysis of the CSD *leikittää* ‘make s.o. play’ (in section 3.5).

## 1.2 Defining a derivational group – causative verbs of social dominance in the twilight zone between grammar and lexicon

In this section, I present the Finnish morphological causatives of social dominance as a productive derivation type in light of the Fennistic tradition. The focus is on the grammatical effects of defining this derivational group. The main goal of this section is to gauge the derivational group of curative causatives. Since there is no unanimous agreement within the literature dealing with word-formation in Finnish about what the criteria are that separate this verb group from other derivatives, I will first discuss different approaches to curative causatives. Explaining this linguistic phenomenon through either transformational processes or lexical relations reflects the productive nature of this morphological process on the one hand and the tendency to idiosyncrasy on the other. I contemplate the definitions and the consequences of them on the organization of grammar based on the following questions: What are the effects of the different definitions on grammar? Which classification is the most appropriate? How homogenous is this derivational group? Are these causatives independent entries in the lexicon or the results of syntactic alterations? As a highly complex cluster, these verbs display both productive and pattern-specific rules, and the claim that they are a coherent category is questionable.

As a word formation tool, suffixal derivation is characteristic to Finnish. To this system belong approximately 200 derivational suffixes, of which 40 are verb suffixes. The suffixes belonging to the latter group can change a nominal root into a verb or modify the meaning of a root verb (ISK 2004: 180, 300). A common way of producing causative verbs in Finnish is by attaching the causative suffix *ttA* to a (nominal or verbal) stem. There is a group of morphological deverbal causatives which are traditionally divided into a separate class in Finnish derivation classification called *kuratiivikausatiivit* ('curative causatives') or 'factitives' (the latter term used for instance in Nykysuomen Sanakirja, the dictionary of contemporary Finnish, hereafter NS). When referring to this term I use the word 'curatives'. The meaning of curatives is basically 'X makes Y do something'. When talking about this reading, I use the term 'curative meaning'. To begin with, I will discuss curative causatives in the linguistic tradition of Fennistics.

The morphological signs of curative causatives are the causative suffix *ttA* or suffix combinations *ttA-ttA*, *U-ttA* and *ttA-U-ttA*<sup>2</sup>. These are the surface forms of the following phonological variations: *ttA* (t, ta, tä, tta, ttä) and *U* (u, ü) (see Kytömäki 1992: 8). While the *t*-element represents the causative

<sup>2</sup> The vocal element A represents the a/ä-variation and U the u/ü-variation which depends on the vocal harmony of a word in Finnish (for an analysis of phonological variations of causative suffixes, see Kytömäki 1992).

component, the *U* between causative suffixes functions mainly as a bonding element making it phonologically convenient to add a causative suffix. The suffix *U* nevertheless has a motivation of its own: according to ISK §303, *U* can add to the base verb the reading of a reflexive (denoting that the activity is directed to the subject referent), automative (indicating a change in the subject referent) or translative (denoting a change in the subject argument, the result of the translative derivation is often the state encoded by the root verb). The *U*-verbs are argued to express basically unagentive processes and non-volitional action (see e.g. Siitonen 1999). The syntactic function of the suffix *U* is to transform the transitive root verb into an intransitive verb (Kytömäki 1977: 73-78), which is an opposite motivation to the causative suffixes. Some examples of curatives and morpheme boundaries are presented in (1):

(1) *tee|tä|ttä|ä*  
do-caus-caus-inf1  
'make somebody make somebody do something'

*kaiva|u|tta|a*  
dig-U-caus-inf1  
'make somebody dig'

*ota|t|u|tta|a*  
take-caus-U-caus-inf1  
'make somebody take something'

*tuo|ta|t|u|tta|a*  
bring-caus-caus-caus-U-inf1  
'make somebody make somebody make somebody bring something'

The function of *U* is, however, not typically observable in causative suffix combinations, therefore, the suffix combination *U-ttA* may also be analyzed as a whole<sup>3</sup>. Because the *U*-element in connection with the causative suffix has lost its semantic motivation, I treat it as part of the causative morpheme (*UttA*) in the analysis of CSDs. The difference between ordinary causatives and curatives, according to Kytömäki (1992: 241), is partly morphological – the general causative suffix *tA* does not produce curatives, whereas both causatives and curatives can be derived using the suffixes *ttA* and *UttA*; the suffix combinations *ttA-ttA*, *ttA-UttA*, and even *ttA-ttA-UttA* are used to ascertain the curative reading. In other words, when it is not clear whether an ordinary causative verb or a curative is in question, the verb can be derived

<sup>3</sup>For instance, Karlsson 1983 assumes autonomous suffix components only when there are semantic grounds to do so.

one step further as in example (2); the word form *haetuttaa* ‘make s.o. fetch’ thus represents a clearly curative verb.

- (2) *hakea* < *haettaa* < *haetuttaa*  
 fetch; fetch-caus; fetch-caus-caus  
 ‘fetch’ < ‘make somebody fetch’ < ‘make somebody make somebody fetch’

The discussion above indicates that a watertight distinction between causatives and curatives cannot be based on morphological clues – we need other criteria. Several descriptions of the Finnish derivational system as in e.g. Penttilä (1957), Hakulinen & Karlsson (1979: 242), Hakulinen (1979: 265–266) and ISK §313-315 have based the definition of curatives on morphosyntactic requirements<sup>4</sup>. According to this view, curatives are by definition causatives derived from transitive root verbs, and as a marker of a curative verb the derivative governs an adjunct in the adessive case. The derivation process is seen as a result of syntactic transformation changing the valence of the root verb. This affects the argument structure as well as the relation between the constituents of the sentence. The figure below (3), taken from Hakulinen & Karlsson (1979:243), illustrates the morphosyntactic approach:

- (3) *Pappi veistättää räätäliillä kirvesvarren*  
 priest carve-CAUSE-pres-3sg tailor-ade axe.shaft-acc  
 ‘The priest makes the tailor carve an axe shaft’

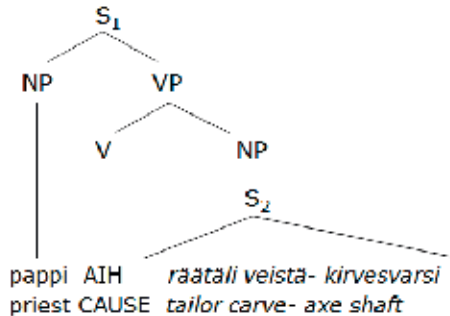

The transformational process describing curative derivation is presented in (4) and (5) where (4) illustrates the argument structure of the base verb and (5) the argument structure of a curative derived from the same base verb. As we can see, the subject argument of the root verb (*räätäli* ‘tailor’) is degraded

<sup>4</sup>Also Siro (1964, 1996) considers the causative derivation as a syntactic process. He does not separate curatives as a class of their own but categorises them under the upper concept of causatives.

to the adjunct position in the constituent structure of the derivative, whereas the object argument of the root verb (*kirvesvarsi* ‘axe shaft’) keeps its position. The derivative adds a subject argument to the proposition (*pappi* ‘priest’ in (5)); a curative verb itself is always transitive.

(4) *Räätäli veistää kirvesvarren*  
 tailor carve-pres-3sg axe.shaft-acc  
 ‘Tim carves an axe shaft’  
*räätäli* ‘tailor’ – subject  
*kirvesvarsi* ‘axe shaft’ – object

(5) *Pappi veistättää räätätilillä kirvesvarren*  
 priest carve-caus-pres-3sg tailor-ade axe.shaft-acc  
 ‘The priest makes the tailor carve an axe shaft’  
*pappi* ‘priest’ – subject  
*kirvesvarsi* ‘axe shaft’ – object  
*räätäli* ‘tailor’ – adessive adjunct

The forming of curatives enables causative suffixes to be attached to one another, which can be said to correspond to the notion of recursivity. In derivation, recursivity represents the replication of the same derivative operation with the same linguistic means. In the case of curatives, this means that every causative suffix is expected to add an extra causer (syntactically functioning as a subject) to the proposition, and there can be intermediary causers in the causal chain (as e.g. in the example (2)). In other words, the same causative suffix modifies the root verb by every derivational step and moves the causer of the event denoted by the root verb one step further (Pennanen 1984: 436). However, when it comes to long chains of derivational suffixes, there is a tendency for the meaning of the suffixes to blur. As a result, multi-suffix curatives often bear the same meaning as their shorter version i.e. both *teetättää* and *teettää* mean ‘make s.o. do’ (Karlsson 1983: 239–241; Kytömäki 1978).

One problem with the syntactic approach to the classification of curative causatives is that it disregards the well-known fact that transitivity is not a clear-cut phenomenon: there are a large number of verbs that can occur both with and without objects or verbs that behave idiosyncratically. Even those verbs regarded as transitive can occur without objects, and intransitive verbs can take provisory objects (Kangasmaa-Minn 1977: 5-6; Leino 1991: 21-35). The aspects of the Finnish object are discussed more closely in section 3.1.1; consider at this stage the examples (6-8), where (6) is a sentence with a transitive verb used in a generic sense, (7) a verb with a cognate object and

(8) contains an adverbial in the partitive, the case typically marking the object in Finnish<sup>5</sup>:

(6) *Tämä hammaslääkäri ei puuduta.*  
 this dentist not anesthetize-pres-ind  
 ‘This dentist does not anesthetize’

(7) *Tyttö tanssii valssia.*  
 girl dance-pres-3sg waltz-part  
 ‘The girl dances a waltz’

(8) *Hinnat laskivat kaksi prosenttia.*  
 price-pl fall-past-3pl two-nom percent-part  
 ‘The prices fell two percent [two percent-part]’

Pajunen (2001: 47) notes that a verb classification based purely on syntactic criteria is only sufficient when studying verbs that encode relations between states of affairs and not the events themselves; examples of the former are e.g. modal verbs and other verbs occurring with infinitives (*täytyä* ‘must’, *haluta* ‘want’, *antaa* ‘let’) that can easily be distinguished syntactically since the main verb has an infinitive qualifier governed by the subject or object argument. Also, the categorization of a derivation group like curative causatives based on morphosyntactic criteria does not work well because of the many exceptions in the otherwise productive system; semantic conditions must be considered, too. In Pajunen’s (2001) classification of Finnish verbs, curatives are argued to belong to the inductive type of causation verbs: in this group of causatives, the agent influences another being and makes it perform a second action. The main arguments of curative verbs must thus be +animate. Kytömäki (1978: 137–139) takes into account the relative nature of verb transitivity, emphasising the semantic discrepancy within both transitive and intransitive verb types. She emphasises the socially interactive nature of the first causation and adds two semantic criteria to the definition of the curative verb class. I call the first criterion the ‘activity criterion’, enabling the curative forming of intransitive root verbs:

***The activity criterion:*** the root verb of a curative verb may be intransitive as long as it indicates action.

The second criterion concerns the semantic roles of the main arguments in a curative sentence: these are comparable to Lyons’ (1968) terms ‘indirect

---

<sup>5</sup>There is a group of ‘adverbials of amount’ that can occur in accusative and nominative cases in Finnish which are the cases of the object. These adverbials behave in an object-like way and are known as OSMA in Finnish literature (Tuomikoski 1978).

agent' and 'direct agent'; Kytömäki uses the more exact terms *teettäjä* 'the person having someone do something' and *toimija* 'the person enacting and executing the action'. The subject argument of a prototypical curative takes the role of the indirect agent, while the subject argument of the root verb takes the role of the direct agent. Let us call the second criterion the 'non-participation criterion':

***The non-participation criterion:*** The essential characteristics of curatives are a consequence of differences in the semantic roles of the two main arguments: the subject argument of the derivative (the indirect agent) must not be involved in activity denoted by the root verb, whereas the subject argument of the root verb (the direct agent, realized as the object of the sentence or as an adessive adjunct) is the performer of this action.

The non-participation criterion appears to be crucial when distinguishing between causatives and curatives. In order to resolve borderline cases, Kytömäki (1978: 142-146) suggests that a verb has a curative interpretation when the indirect agent does not take part in the action, and causative interpretation when the indirect agent is understood to be taking part in the action. Hence, the semantic view recognizes that the demarcation of curatives is not a straightforward matter and that these verbs in fact represent a context-dependent phenomenon.

Let us now consider the argument structure of examples with an intransitive root verb and a *ttA*-causative derived from the same verb, presented in (9) and (10). When comparing the arguments of these examples, we can see that the subject argument of the root verb is the object argument of the derivative, expressed by the accusative case in (9). Notice that in comparing the curative derived from the transitive verb *maalata* 'make s.o. paint' to the proposition in (4), the curative meaning 'X makes Y do something' also holds when the root verb is intransitive (as in (10)).

(9) *Tim juoksee*

Tim run-pres-3sg

'Tim runs'

*Tim* – subject

(10) *Jane juoksuttaa Timin kauppaan*

Jane run-caus-pres-3sg Tim-acc shop-ill

'Jane made Tim run to the shop'

*Jane* – subject

*Tim* – object

Hence, the inclusion of semantic criteria in the morphosyntactic definition of curatives implies that *ttA*-causatives derived from intransitive roots can, under certain conditions, also be seen as curatives. However, the semantic criteria are not completely straightforward. For instance, when using the activity-feature of the root verb as a criterion, we need to specify what exactly is meant by ‘activity’. Does it include mental activity? Is it essentially a feature of the root verb or the derivative? Consider for instance the derivatives of transitive but non-active root verbs like *rakastuttaa* ‘make s.o. love’, *hyväksyttää* ‘make s.o. accept’, *ihailuttaa* ‘make s.o. admire’, *tunnistuttaa* ‘make s.o. identify/recognize’ and *katsottaa* ‘make s.o. watch’, which seem to adopt both curative syntax and semantics (see examples of language use in (11-15)). Mental processes denoted by the root verb thus take on characteristics of a controlled activity in a curative derivative. Even verbs denoting perceptual activity like *ihaillla* ‘to admire’ and *katsoa* ‘to look/watch’ seem to adopt the curative meaning when added to the causative morpheme. Note that examples (12), (14) and (15) include the direct agent in the adessive expressing the subject argument of the root verb.

(11) *rakastuttaa* [love-caus] ‘make s.o. love’

*Karvinen on rakastuttanut yleisöään jo yli kahden vuosikymmenen ajan.*  
‘Garfield has been **making** audiences fall in **love** with him for more than two decades.’

(<http://www.bananapress.fi/Shopit/Shop1.html>, 30.8.2005)

(12) *hyväksyttää* [approve-caus] ‘make s.o. approve’

*Projektikohtaiset hankinnat tulee yleensä erikseen hyväksyttää tilaajalla ennen hankinnan toimeenpanoa.*

‘The deliveries have to be (made) **approved** by the orderer [orderer-ade] before delivery is carried out.’

(<http://www.stul.fi/rakinfo/hyva%20toimintatapa.HTML>, 16.9.2005)

(13) *ihailuttaa* [admire-caus-pres-3sg] ‘make s.o. admire’

*Arvostettu käräjätuomari Harrison [Marc Kudisch] vie Samanthan jatkoille poikamiesboksiinsa Museum Towerin 39. kerrokseen. Koska miehellä on silmää myös maisemille, hän ihailuttaa ensin siltanäkymää ennen kuin ehdottaa seuralaiselleen muuta.*

‘The respected referee Harrison takes Samantha to an after-party at his bachelor pad on the 39<sup>th</sup> floor of the Museum Tower. As he has an eye for views, he **lets** the company **admire** the view of the bridge before suggesting others.’

(<http://www.mtv3.fi/ohjelmat/sinkkuelamaa2002/viikonmies.shtml/2?87809>, 24.10.2005)



- (14) *tunnistuttaa* [identify-caus] ‘make s.o. identify’

*Muuta esineistöä on mahdollisuus **tunnistuttaa** aikaisempien kesien tapaan antiikin asiantuntija Kari Toivosella.*

‘It is possible, as in previous years, to **let** antique expert Kari Toivonen [Toivonen-ade] **identify** the other items.’

(<http://www.esaimaa.fi/arkisto/vanhat/2002/04/15/talous/juttu1/sivu.html>, 24.10.2005)

- (15) *katsotuttaa* [watch-caus-caus] ‘make s.o. watch’

*Kaikilla on varmasti ollut tiedossa historian tapahtumat, joista huippuna MM-kisat 1986 ja ne kuuluisat 40 sekuntia. Helsingin sanomat **katsotutti Hannu Järvenpäällä** tuon -86 Suomi-Ruotsi -ottelun ja sitä Kuukausiliitteestä lukiessa tuntui, että eihän sellainen enää voi olla mahdollista.*

‘Everybody is surely aware of the historical events culminating in the world championships in 1986 and those famous 40 seconds. *Helsingin sanomat* **made** Hannu Järvenpää [Järvenpää-ade] **watch** that Finland-Sweden match from ’86, and reading that from the monthly pull-out it felt as though it could no longer be possible.’

(<http://koti.phnet.fi/jsinkkon/vanhat/mm2003.htm>, 9.11.2005)

On the other hand, even the *ttA*-derivatives that have a stative verb as their root seem to adopt a valid curative reading, as for instance in *jonotuttaa*<sup>6</sup> ‘make s.o. queue’, *istuttaa* ‘make s.o. sit’ and ‘*odotuttaa* ‘make s.o. wait’. In these cases, the coercive nature of the activity of the indirect agent is emphasized. Consider sentence (16), where the activity of the second agent can be interpreted as passivity. Does this derivative count as a curative?

- (16) *Ovimies jonotutti ihmisiä ravintolaan*

doorkeeper queue-caus-past-3sg people-part restaurant-ill

‘The doorman had people queue for the restaurant’

The *ttA*-derivation thus seems to *add* an activity feature to otherwise non-active verbs, functioning in a sense like an activizer. This suggests that curatives can be derived even from non-active root verbs, and furthermore that the activity of the second agent in a curative sentence is not necessarily a feature of the root verb but of the derivative structure. The second agent is interpreted as an active participant because of the derivative structure i.e. the root verb is adjusting to the derivation pattern, regardless of the root verb’s

<sup>6</sup>The root verb of *jonotuttaa* ‘make s.o. queue’ is *jonottaa* ‘to queue’, which is not a causative verb, though it includes the morpheme *ttA*.

properties. Can the activity of the second (direct) agent be regarded as the unifying property of these derivatives in the lexicon?

Another semantic effect of *ttA*-derivation arises from the characteristics of the two animate participants with the roles of indirect and direct agents or the non-participation criterion. According to Kytömäki (1989: 62–67), in a prototypical curative proposition the indirect agent sets the direct agent an assignment, after which the direct agent carries out the action and the indirect agent does not participate in the action itself; the connection between the agents is of a communicative nature. Hence, the social relation between the agents becomes significant in distinguishing curatives from ordinary causatives. We can conclude that another impact of the *ttA*-morpheme on the root verb is that it adds a social causal relation to it<sup>7</sup>. Is the non-participation criterion an automatic consequence of derivation? In the prototypical case the direct agent is expressed as an adessive adjunct, but it can be replaced with object cases. According to Kytömäki (1989: 62–63), the expression of the direct agent syntactically as the object stresses the indirect agent's participation in the activity of the root verb (as in example (17a)), whereas the adessive adjunct of the indirect agent gives a reading of non-participation (17b); the examples are from Kytömäki:

(17a) *Opettaja kävelytti lapsia koko matkan.*  
 teacher-nom walk-cause-past-3sg child-pl-part whole route-acc  
 'The teacher had the children walk the whole route (and did so herself).'

(17b) *Opettaja kävelytti lapsilla koko matkan.*  
 teacher-nom walk-cause-past-3sg child-pl-ade whole route-acc  
 'The teacher had the children walk the whole route (but did not necessarily do so herself).'

However, this cannot be regarded as a constant, as example (18) using the verb *tanssittaa* 'make s.o. dance' shows:

(18) *Mikko tanssittaa Maijaa.*  
 Mikko dance-caus-3s Maija-part  
 'Mikko makes Maija dance.' OR 'Mikko dances with Maija.'

Thus, the non-participation interpretation is not unambiguously a property of the derivative or the syntactic appearance of the arguments. In the case of (18), there are two possible readings, and the choice between them is made

---

<sup>7</sup>The type of causation in terms of directness raises the question as to whether it is characteristic of social causation that it is indirect. What would direct social causation be like? I discuss a type of direct social causation in section 5.2.4.1 in connection with competitive situations.

on the basis of contextual background knowledge – we cannot say if Mikko is dancing with Maija or not without knowing more about the situation. Hence, the connection to the contextual background of the curative proposition is particularly significant. What are the consequences of this for the verb in question: can we classify it as a curative? Are there different derivatives for cases where the indirect agent participates in the activity and for cases where it does not? If we categorize a derivative as an unclear curative, what are our grounds for such a declaration, and how do we compare clear and unclear cases?

The discussion above leads us to the question of how justifiable and well-founded the distinction of curatives as a verb class in general is. The conclusion drawn on the basis of the examples above is that the type of inducement practiced by the indirect agent on the direct agent is a highly context-dependent phenomenon, thus complicating the classifying of curatives. This suggests that the morphosyntactic and lexical means to study this phenomenon are not sufficient; for a better understanding of these derivatives it is essential to consider the verbs in the settings within which they actually occur. For this purpose, I have randomly sampled a corpus of CSDs (I will now return to the term of this study) from the Finnish Language Text Collection as well as from language use on the Internet (regarding the materials of this study, see section 2.3). Most of the authentic examples in this study are taken from these sources.

Language use materials reveal certain tendencies that CSDs have, complicating the overall picture. One propensity is ascribed to the property of verbs to have homonyms, submeanings and idiomatic readings – and even these can be derived. Consider examples (19) and (20) reflecting the use of the verb *käytättää*. Example (19) is derived from the root verb *käyttää*, which has the lexicalised meaning of ‘to use’ in Finnish; the direct agent in this sentence is implicit. The second example of *käytättää* in (20) is derived from the motion verb *käydä* ‘to go’ as *käyttää* and further with an additional causative suffix as *käytättää*, both meaning ‘make s.o. go’. The double causative suffix combination basically leaves the meaning of the derivative from the single causative variant unchanged. Note also that the subject referent of the root verb *käydä* ‘to go’ is not human but still animate, syntactically functioning as the object. Example (21) includes the predicate *tanssittaa* ‘make s.o. dance’; remarkably, the idiomatic utterance *tanssia jonkun pillin mukaan* meaning ‘dance to someone else’s tune’ is made causative using the *ttA* suffix.

(19) *käytättää* [use-caus] ‘make s.o. use’

*Arafatin kansansuosioista en tiedä mitään varmaa, mutta aseiden tuki hänellä ainakin on, ja aseita hän haluaa käytättää.*

‘I don’t know anything for sure about Arafat’s popularity, but at any rate

he's got the support of weapons, and he wants them **to be used** (to make his subordinates use the weapons).'

([http://chat.yle.fi/cgi-bin/uutiset/keskustelu/ultimatebb.cgi?ubb=get\\_topic&f=11&t=000118](http://chat.yle.fi/cgi-bin/uutiset/keskustelu/ultimatebb.cgi?ubb=get_topic&f=11&t=000118), 16.9.2005)

(20) *käytättää* [go-caus-caus] 'make s.o. go'

*Ystäväni **käytättää** erittäin edullisessa eläinlääkärissä Helsingissä kissojaa ja koiriaan.*

'My friend **takes** his cats and dogs (has them go) to a very affordable vet.'

(<http://www.aulabaari.net/modules.php?name=AulabaariFoorumit&op=showthread&id=1&rid=78506>, 16.9.2005)

(21) *tanssittaa* [dance-caus] 'make s.o. dance'

*Näitä avuttomia lampaita on sitten johtajien helpompi **tanssittaa** pillinsä mukaan.*

'The leader can then **make** these helpless sheep more easily **dance** to their tune.'

([www.iltalehti.fi/keskustelu/post!reply.jspa?messageID=3141873](http://www.iltalehti.fi/keskustelu/post!reply.jspa?messageID=3141873), 30.8.2005)

Another observation based on language use is that CSDs may occur in certain specialized patterns. I will present here one CSD construction; both is and the verbs occurring in the pattern are discussed more thoroughly in chapter 5. In connection with some causatives, there is a particular social relation between the indirect and direct agent with the interpretation of power abuse. For example, the verb *tanssittaa* 'make s.o. dance' can be used as a part of a construction I call the 'Power Misuse Construction' in addition to its neutral reading as presented in (18) and the idiomatic phrase presented in (21). I argue that the Power Misuse Construction attracts certain verbs; a group of verbs central to this construction are derived from motion verbs, for instance *juoksuttaa* 'make s.o. run' and *hyppyttää* 'make s.o. jump' as in example (22):

(22) *hyppyttää* [jump-caus] 'make s.o. jump'

*juoksuttaa* [run-caus] 'make s.o. run'

*Palvelu on yrmeätä vastaanottovirkailijasta lääkäriin. Tuntuu, kuin päätarkoitus on **hyppyttää** ja **juoksuttaa** asiakasta.*

'The service is unfriendly from receptionist to doctor. Its main purpose seems to be to **make** the patients **run** around in circles and **jump** through hoops.'

(<http://www.otakantaa.fi/forum.print.cfm?group=174>, 0.8.2005)

An interesting development in the Power Misuse Construction is that the pattern is not restricted to causatives derived from motion verbs. There are also ‘denominal curatives’, verbs derived with the *ttA*-morpheme which are associated with the Power Misuse Construction, such as *pallottaa* [ball-caus], *kyykyttää* [squat-caus] and *pomottaa* [boss-caus], and which can be used in the sense of ‘boss s.o. around’. Also, the CSD from example (22), *hyppyttää* [jump-caus], is thought to derive from the noun ‘jump’, although the verb ‘jump’ is also possible as the root in this case. Consider the example with the verb *pallottaa* in (23). Example (24) includes the verb *penkittää* (bench-caus), which roughly translates as ‘make (a team) player sit on the bench’, a sports term closely related with the *ttA*-causatives derived from static verbs (compare it to example (16)). Both examples include a connotation of power misuse, since it is not acceptable to boss colleagues around or positive for a football player to be forced to sit on the bench during a match. The derivative pattern of curatives together with the constructional pattern thus model the root noun so that it behaves as a predicate denoting activity and taking a (human) argument that is dragooned into humiliating or involuntary activity.

(23) *pallottaa* [ball-caus] ‘boss s.o. around’

*Ja vielä kehtaavat sisäisesti **pallottaa** uusia tulokkaita että tehkäpä nyt kuuliaisesti täysi työpäivä kun me muut lähdetään päiväkahvien jälkeen kotiin!*

‘And they even have the nerve to **boss** the newbies **around**, saying “do what you’re told and do it all day”, while the rest of us go home after our coffee at lunch!’

(<http://www.taloussanomat.fi/keskustelut/post!reply.jspa?messageID=1130053>, 19.6.2007)

(24) *penkittää* [bench-cause] ‘make a player sit on the bench (in reserve)’

*Kärjessä häärivät viime matsissa Rooney (no, tavallaan kai kärjessä?) ja Henkke, joista Waynen maalista huolimatta molemmat olisi mielestäni syytä **penkittää** tähän peliin.*

‘In the last match Rooney and Henkke both bustled in front (well, sort of in front?), and both of them should have been **made to sit on the bench** for this game, despite Wayne’s score.’

(<http://foorumi.paitsio.com/ottelut/2189-united-fa-cup-06-07-a.html>, 24.4.2007)

In the light of the discussion above, which definition of the curative verbs is more convenient: morphosyntactic or syntactic-semantic? Do curative verbs function according to syntactic rules? How does the demand of the transitivity of the root verbs work? How tenable are the activity criterion and the non-participation criterion? Can the linguistic phenomenon of curative

causatives be determined by these criteria?

An implication of defining a verb class is that the definition specifies the productivity restrictions of producing new derivatives. As Kytömäki (1978) points out, there are no structural restrictions in deriving new curatives, and this derivation type is regarded as highly productive. The compositional classification of curatives, describing them as the results of the system enabling perpetual production of new derivatives with a regular semantic relation to the root word, is the hallmark of a productive derivation suffix. This idea is based on the expectation that by adding the causative morpheme *ttA* we make a root verb causative, and that adding two causative morphemes makes the verb a double causative ('X makes Y make Z do something'). The causative suffix is thus considered to incorporate the causative meaning *per se*, and the result of the derivation process should be predictable. The most important condition of the regularity and productivity of the derivation type, according to Karlsson (1983: 264), is its ability to perpetually produce new occasional/temporary derivatives by attaching roots and morphemes. However, the assumption that the derivation system is straightforward and transparent reflects an 'ideal situation' that does not hold true in all aspects, and the result may be semantically and syntactically different than predicted. Another question is: how can we detect when a curative is just an occasional case? How many times does it have to occur before it is an established lexeme?

Within Finnish linguistics dealing with word formation, the term *lexicalization* usually refers to the establishing process of a multimorphemic item in the lexicon, after which the meaning of the item cannot (morphologically and semantically) be deduced from its component parts i.e. it is an opaque lexeme that cannot be divided into components (see Kytömäki 1991; Karlsson 1983: 263; ISK 187). Relying on Shippan (1984: 95-96), Räisänen (1988:18) suggests that lexicalization should comprise the transparent derivatives that have become part of lexicon, whereas the derivative lexemes that have lost their transparency should be treated as the results of *idiomatization*. This approach enables us to account for different kinds of derivatives in the lexicon; but determination of the actual criteria for demarcation between lexicalization and idiomatization is a complex issue. Because of the comprehensive exposition of morphology, morphological systematizing has been prioritised at the expense of such other areas as lexical idiomacity and the heterogeneity of the Finnish derivation system (see Flint 1980 and Siitonen 1999). Kytömäki (1990: 71) emphasizes the heterogeneous characteristics of derivation – her viewpoint is that the system is built on separate words that function as models for new derivatives and which are supported by functional type in the background. She also points out that word formation as a system has a strong holistic power; for instance, the denominal verb derivation type can at the same time be supported by the deverbal derivative type. In my opinion, the denominal curatives presented

above are proof of such correspondence between different derivation types.

Itkonen (2006) argues that less clear representatives of a category do not rule out the clear cases; a category exists despite cases that are “both A and not-A”. Is there a class of curative causatives based on a transformational rule? As the discussion above shows, the boundaries of the curative category are blurred. This itself does not bring into question the existence of a class. However, we may ask whether there are clear cases at all: is classification in fact baseless? What is the justification of curatives as a separate verb class? How clear should the members of a category be?

In this study I strive for a description of CSDs that takes into account both the general properties of these derivatives and irregular relationships. I do not assume that these causatives are derived transformationally from an underlying sentence (*Matti juoksuttaa Pekan kauppaan* ‘Matti makes Pekka run to the shop’ > *Pekka juoksee* ‘Pekka runs’). The examples discussed above suggest that when it comes to curative causatives, the lexicalist hypothesis of Chomsky (1975) has a stronger explanatory power than the transformational account: derivation morphology is not necessarily based purely on changes in the syntactic component – there are also systematic relationships in lexicon. I argue that the *ttA*-causatives are distinct but related lexical entries; hence even transparent curatives have their place in the lexicon. Jackendoff (1975) proposes an account of the ‘redundancy rules’ of “separate but related lexical entries” to explain the connection between associative lexemes; the semantic and syntactic similarity of the causative verbs in this approach is seen in their lexical entries.

The questions regarding CSDs then are: what are the salient features of these verbs? What is the relationship of these shared or similar properties based on? The ‘similarity’ relation implies that word derivation may function as a model-based formation founded on analogical linkage, where a new construction becomes common on the grounds of a single innovation. The basic relation between the lexemes may then be described as an analogy-based relationship – the structural and/or functional similarity of a linguistic phenomenon in relation to another (the power of association behind the dynamics in language is emphasised, for example, in Anttila 1977 and Itkonen 2005).

In this study I argue that instead of a derivational group of curative causatives, there are various, heterogeneous criteria behind the groupings of the verbs. As a highly complex cluster, these verbs are subject to both productive and pattern-specific rules; the diversity of the derivation system should be recognised. The term ‘causative verbs of social dominance’ (CSD) is used in this study as an umbrella term for the verbs under examination. I treat these derivatives as independent lexical entries with social dominance and indirect causation as common characteristics; any contracted sentence or independent syntactic predicate of derivative relation in the background of the CSDs is not assumed. The systematic similarities are captured through the

---

prototype patterns of the CSDs; the central elements are social causation and activity of the direct agent. The description of prototypes also involves the linking correspondence between the syntactic and semantic levels. The discussion here also involves generalizations made on curative causatives. How do the syntactic and semantic properties actually correlate? Is the implicit adessive adjunct merely a feature of derivatives with transitive roots? The syntactic behaviour of the CSDs is the particular focus of chapter 3, where the transitivity of the root verbs and the exact connection of the root verb arguments to the derivative verb is investigated in more detail. The main goal of the analysis is to discover how the lexicon works. Are there natural verb groups, and if so, what are the principles behind the groupings? CSDs are closely connected to context; therefore, it is essential to take the surroundings of causatives into greater account. I strive for a formal description of CSDs and an inclusion of a usage-based approach.



## 2 Theory and methods

### 2.1 Theoretical background: conceptual semantics

The way of thinking on the essence of language in this study is based on framework of conceptual semantics. This theory has human cognition and linguistic structure as its research topic. Conceptual semantics originates from generative linguistics as initiated in Chomsky (1957) and laid out in the extended standard theory (Chomsky 1965) that assumes a mapping of the semantic representation onto the deep structure of a sentence and the transformation of the latter to the surface structure. In contrast to the transformational view of generative semantics, assuming that semantic interpretation is derived from syntax, Jackendoff (1972) developed a theory whereby semantic representation has an autonomous status. This widened the generative system of language from a syntactocentric approach to the semantic component of grammar. The conceptual semantics theory sprang from the ideas of Ray Jackendoff (1972, 1983, 1990 & 1997) and has been developed by Pinker (1989), Nikanne (1990, 1995, 1997 & 2006), Pörn (2004) and Petrova (2009, 2011). This section is primarily an overview of the theoretical foundations of conceptual semantics as well as an outlining of its overlap with other linguistic approaches (for the historical background of conceptual semantics theory, see for example Nikanne 2008).

What kind of research object is language? Saussure (1966 [1915]: 7-11) pointed out the complexity of the only ostensibly straightforward answer to this question: the production of language is tightly bound to perception, phonological form to meaning, the individual side of language to the social, synchronic to diachronic. Wherever we approach language, it always seems to have another closely related side. Given the diversity of linguistic phenomena, a comprehensive linguistic theory cannot confine itself to discovering and describing these different aspects of language in isolation, but must attempt to explain the connections between different levels of language.

On a general level, the conceptual semantics theory strives for a solution to this problem by uniting the knowledge of different aspects of language that we already have, as well as integrating knowledge from neighbouring disciplines into the description of the language. The backbone of conceptual semantics is the cognitive approach to language: the theory strives to outline the theory of the human mind, with language as the central part. This goal leads to the following research questions: What is the status of human language in the mind? How does language conceptualize the world? The underlying impulse to this approach comes from the central stance in generative grammar that the structure of natural language is a psychological

---

phenomenon of genetically encoded character. In terms of Chomsky's (1986) division of linguistics into internalized language (I-language) and externalized language (E-language), conceptual semantics focuses for instance on the question of how linguistic competence or the I-language is related to language-processing. In other words, conceptual semantics assumes that the rules of mental grammar are at least partly stored in memory and available in the course of language-processing (Jackendoff 1997: 7-8). The nature of this mental grammar is a central issue within conceptual semantics.

The essence of conceptual semantics theory lies in its approach to linguistic meaning. Jackendoff (1983: 11-18) argues that a proper semantic theory should combine the knowledge we have about syntax and lexicon with the psychological reality of linguistic information (the grammatical and cognitive constraint of linguistic theory respectively). The most important hypothesis of conceptual semantics is that in accordance with syntax and phonology, linguistic meaning is also (cognitively) organized. This claim extends the assumption of generative grammar to semantic structures while the autonomous level of syntactic representation is still assumed. One result of this separation of levels is that syntax is relieved of unnecessary abstraction which the assumption of semantic phenomena as syntactic structures brings to the analysis. No level is thus assumed to be derived from another (e.g. meanings are not derived from sounds) but regarded as equally autonomous (Jackendoff 1990: 19).

As a consequence, Jackendoff (1983: 16-18) proposes that there must be a level of mental representation that transmits information from language to cognitive faculties and vice versa, basically making it possible to talk about what we hear and see. He refers to this representation in which linguistic information is compatible with sensory and motor information as 'conceptual structure' (CS). It is important to note that the conceptual structure hypothesis comprises a larger viewpoint of semantics than the more standard assumption of a specifically linguistic semantic structure. CS is understood as an organization of thoughts that language can express, including pragmatic and contextual considerations; it is regarded as the centre in which our cognitive reasoning, including dimensionality, spatial language and body representation, takes place (Jackendoff 2003: 123, 1992). It should be pointed out that within conceptual semantics, the formation of conceptual structure representation is not necessarily seen as a homogenous module. While Jackendoff is talking about one level of CS, van der Zee & Nikanne (2000) argue that the interface between linguistic and extralinguistic information constitutes a division of several different representational modules, such as spatial structure and motor structure. The micromodular approach is called the 'Tinet model'; this approach is discussed in more detail in section 2.2 below.

In the conceptual semantics view, language is a structured system; furthermore, there are different kinds of structures. The main question is not

just the inner organization of different formations but how they are related to each other. According to Nikanne (2002), the research goal of conceptual semantics is finding the smallest autonomous structures with their primitive units and the combination principles between them. Another research topic is detecting the basic mapping rules between these structures; linking between representations is not assumed to be one-to-one. This is reflected for instance in the treatment of the theta-criterion: in contrast to the idea that there must be a one-to-one correspondence between noun phrases and thematic roles, a nominal may be assigned by several roles.

The ‘representational modularity’ (Jackendoff 1997) idea suggests that the organization of language is based on different autonomic components that are in interaction with each other. The modules of phonology, syntax and conceptual representation cover their own primitives and principles of combination each. The rules of representational well-formedness within a representation are described by a set of ‘formation rules’. The representations and non-linguistic domains (vision, action etc.) are linked by a set of ‘correspondence rules’. Lexicon in this theory consists of elements that combine information from different levels, specifying a word’s phonological form, syntactic category and conceptual characteristics. The third set of rules concerns the mapping of conceptual structures as conceptual structures – the ‘rules of inference’<sup>8</sup>. In generative linguistics models in general, morphology is assumed to be a language-specific component serving the syntactic rules of the grammar. Also in the Jackendovian approach, morphology is not a separate representation but forms part of the correspondence rules between syntax and conceptual structure (Jackendoff 1983). (For the organization of grammar in conceptual semantics, see also Jackendoff 1983 18-22; 1990: 16-18.) The representational modularity view of the organization of grammar in conceptual semantics as outlined in Jackendoff (1990: 16) is presented in Figure 1:

---

<sup>8</sup>According to Jackendoff (1975), the inference rules in conceptual semantics are basically formalized in the form *conceptual structure 1 => conceptual structure 2*, under certain conditions (see also example (5)).

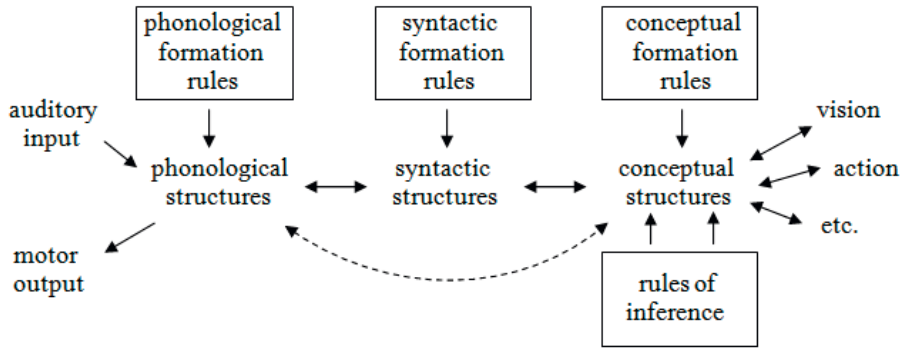

Figure 1. The organization of grammar in the representational modularity approach

Conceptual representation is assumed to be universal<sup>9</sup>; language-specific semantic differences are explained by different ‘linking rules’ between the linguistic and conceptual levels. This theoretical conclusion provides for an identification of the language-specific differences in an explicit way (for a comparative approach to conceptual semantics, see Pörn 2007). Lexicon in this organization has no domain of its own because it forms part of the linking rule system, connecting the syntactic, semantic and phonological properties of a word. Consequently, sentential and lexical concepts are combined by the same primitives and principles of combination. Word formation rules with morphological and semantic relationships between derivatives also belong to the lexicon in this theory. The conceptual representation of a word, or ‘Lexical Conceptual Structure’ (LCS), is understood as the level of understanding linguistic information, a link between linguistic representations as phonology and syntax and other cognitive domains (spatial, social, haptic knowledge etc.) (Jackendoff 1990; Nikanne 1997, 1998 & 2008). Basically, by analysing the possible LCS of a word, we ask what it is we know when we recognize a lexeme. How is acoustic, visual, spatial, emotional and social information encoded in language?

The meaning in this system is a rich combinatorial system, and the conceptual structure consists of its own primitive units. In a sentence, each constituent belongs to a major ontological conceptual category – Events, States, Places, Paths, Time, Direction, Property, Amount etc. These

<sup>9</sup>Jackendoff (1983: 17) assumes that conceptual structures function in accordance with a finite set of ‘conceptual well-formedness rules’. These rules are considered universal and innate in the sense that human beings have essentially the same capacity to develop concepts; however, the concepts one actually develops must depend to some extent on experience. Fodor (1975) argues that relevant conceptual dimensions (such as color distinctions) must be available to the language learner in order to formulate hypotheses about the world.

categories are ontological in the sense that they reflect the way in which human language categorizes the world, or the other way around – the world dictates, to some extent, the ontological categories of language and our perception. The goal of the formal conceptual description is to clarify the psychological nature of these basic semantic concepts and to show how they are encoded syntactically and lexically (Jackendoff 1983: 51-52). Nevertheless, the argument presented by Langacker (1987: 189) that syntactic categories have a fixed conceptual basis (for example, the syntactic category Verb corresponds to the semantic category Process and the Substantive to the category Thing<sup>10</sup>) is not assumed in conceptual semantics. The general principle of the relationship between syntactic and ontological categories within conceptual semantics is assumed as follows: every major phrasal constituent in the syntax of a sentence (S, NP, AP, PP etc.) corresponds to a conceptual constituent that belongs to one of the major ontological categories (Jackendoff 1983: 63-70). Thus, there is a certain correlation between syntactic and conceptual categories, but no trivial one-to-one relation. The mapping relations between representations may vary; I discuss the linking system in conceptual semantics in connection with the methodological discussion in section 2.2.2.

The intrinsic structure of the categories as well as the well-formedness rules that determine the relations between the categories are analysed through the rules of inference or the ‘rewriting rules’ of the thematic tier architecture. These rules are structures consisting of functions and their arguments – a function maps its arguments into a larger constituent. The thematic tier expresses the situation structure involving notions such as change, causation and state. The rewriting rule of a causative event is presented in (1) (for an introduction to the basic rewriting rules, see Jackendoff 1990: 43-46):

$$(1) \text{ [EVENT] } \rightarrow \left[ \text{Event CAUSE} \left[ \left\{ \begin{array}{c} \text{THING} \\ \text{EVENT} \end{array} \right\} \right], \text{ [EVENT] } \right]$$

The rule (1) expresses that a conceptual constituent belonging to the category Event can be elaborated as the event-function CAUSE that takes two arguments. The first argument of CAUSE is the agent if it belongs to the category Thing or the cause if it is from the category Event. The second argument of that Event is the effect of the causation event. This rule covers sentences like (2a-b):

(2a) *Mike threw the ball to Jane.*

(2b) *The sun dried the lawn.*

---

<sup>10</sup>Interestingly, the word ‘process’ itself, here used to categorize Verb, is a noun (thanks to Olli Lagerspetz for pointing out this obvious contradiction in the seminar of scientific philosophy).

The function-argument organization of sentence (2a) is thus, as in (3):

- (3) [<sub>Event</sub> CAUSE ([<sub>Thing</sub> MIKE, [<sub>Event</sub> GO ([<sub>Thing</sub> BALL],  
[<sub>Path</sub> TO ([<sub>Thing</sub> Jane])])])])]

Nikanne (1990) proposes a more restricted form of the conceptual structure which takes into account certain constraints which the rewriting rules embody. This model asks, for instance, why structures like (4a-b) are impossible:

- (4a) *A man walks woman is to the yard.*  
\*[GO ([MAN], [BE ([WOMAN], [TO ([YARD])])])]
- (4b) *A man throw to the yard.*  
\*[CAUSE ([MAN], [TO ([YARD])])]

The ‘tiernet model’ of conceptual semantics is a combination of modularity and connectionism ideas, developed in Nikanne (2002). It arises from the restrictions related to representations and their division into tiers assumed in the conceptual semantics model of Jackendoff. A problem here is that it is not always possible to identify which autonomic structure is an individual representation and which is a tier of a representation. Consequently, Nikanne questions the necessity of representations, and suggests that the organization of grammar (and the mind) can be seen to be based on tiers and the linking principles between them. The tiernet model is an open structure in the sense that it enables us, in a more flexible way, to take into account differences between languages; languages may (at least partly) make use of different tiers and linking rules. The tiernet approach also strives for as simple structures in its ‘micromodules’ and their linking systems as possible. The significant innovation of the tiernet model is that it has captured the Jackendoffian rewriting rules in a more general rule – the rule of a well-formed CS expressed by a well-formed function-chain. I will return to the notion of the function-chain in section 2.2.1 below.

The conception of modularity thus varies in the division and scope of the information that the modules are considered to comprise, from larger units to smaller. In Fodor’s (1983 & 1975) modular theory of the mind, language is one large module among the other cognitive faculties of the human mind, a representational mechanism that can represent the world or the alternatives of possible worlds. Jackendoff (1990 & 1997) assumes three central modules divided into tiers. Nikanne (2002 & 2006) has divided these large modules further and taken the idea of modularity towards the connectionist theory. The fundamental property of the tiernet model is that there is no ‘central processing module’. Additionally, the tiernet model differs from other modular approaches in that the modules and connections are not assumed to

be homing; the links strengthen and weaken in compliance with language use (Nikanne, personal communication). For the purposes of this study i.e. an analysis of morphological causatives, the tiernet alternative seems to provide the best foundation, as it enables us to examine smaller modular categories in an explicit way. The tiernet model also takes into account morphology, which is particularly necessary when it comes to Finnish. Since the tiernet model is the modular approach I apply in this study, I introduce its formalism in more detail in section 2.2.3.

Let us now reflect on the question as to what the formalization of language implies. Obviously, formal analysis as such does not give us ‘new’ information by definition. By formalising linguistic information, we aim to reformulate the intrinsic architecture of language that already exists – a system we do not think about when using language. Hence, formalism is understood as a means to help us understand the phenomenon we aim to describe. At its best, this method enables us to construct a model that reflects the nature of language in a meticulous way and at the same time takes the analysis *outside* of the language, in the sense that the description is not made by using language itself.

There are certain aspects that a proper, formal description must satisfy. Firstly, formalism must be based on explicitly noted attributes, in order to attain a clear thesis. Only then will a formal description have any consequence in the sense that the claim can be tested and proven or falsified, generalizations made, different analyses compared and so on. Obviously, the formal description cannot comprise every aspect of a phenomenon as complex as language – part of it is always left out of the analysis. The idea is that by analytically examining the research subject, finding and defining the primitives and detecting their combination rules, we can aim to produce a precise account of a linguistic phenomenon. It is also clear that it is impossible to include every aspect in the analysis; parts of the description must be left for later analysis. A formalized generalization is thus not necessarily an exhaustive description of a phenomenon but rather an understanding of it at a given moment – knowledge possibly in development. The principle of a strict account is that we can broaden it step by step towards improved knowledge.

An example of the formalism of conceptual semantics is lexical redundancy rules i.e. a mechanism that relates lexical entries in the mental lexicon, suggested by Jackendoff (1987). The causative alternation is regarded as including the syntactic change of subject to object and agent to subject. This is basically an operation of taking a lexical entry as input and supplying the entry with new information, with a new entry as a result. Another example is the inference rules. The inference rule of causation presented in (5) is a simplified version of Jackendoff (1990) and Nikanne (1990 & 2008); the rule expresses that if situation X is successfully caused, X

will take place after the causing event (the aspects related to the notion of causativity are discussed in more detail in section 2.5).

(5) CAUSE  $\rightarrow$  X  $\Rightarrow$  X

It is motivating here to compare the methodology of conceptual semantics with the cognitive grammar approach, as the theoretical basis and research goals of these theories are closely related in certain aspects. Both theories recognize the significance of semantics in our cognitive processing, and moreover, in these theories the linguistic meaning is equated to conceptualization and is thus the central research subject. Jackendoff (1983:3) manifests the connection between semantics and cognition thus: “To study semantics of natural language is to study cognitive psychology”. This standpoint is directly comparable with the approach of cognitive grammar; compare Langacker’s (1991: 2) statement that semantics is found in our cognitive processing, not in objective reality. Thus, both theories are unanimous in the cognitive nature of linguistic meaning.

However, these two theories approach the architecture of language in fundamentally different ways. As discussed earlier, within conceptual semantics the basic categories of language are explained as independent modules. These modules have their own primitives, which may be linked with each other within a module or between them. In this way we can specify the connection of one specified category to another. In cognitive grammar, the categories are instead seen as parts of the (same) continuum, which is not based on clear-cut categories (Langacker 1987 & 1991; Lakoff 1987). Langacker (1991:116-120) defines the grammar of a language as a structured inventory of conventional linguistic units where the ‘phonological space’ and the ‘semantic space’ form an abstract, a bipolar ‘symbolic space’ without clear-cut boundaries. Syntax in this theory is reduced to semantics, with the consequence that the basic grammatical classes are defined semantically; lexicon, syntax and morphology are seen as a continuum of symbolic structures which are not divided into separate components. The bipolar phonological and semantic units cannot be separated. Grammar, in cognitive grammar theory, is seen as a list of conventionalized linguistic units which is not based on clear-cut categories but rather on continuums and networks. This fundamental distinction in categorization has major effects on the methodology of these approaches.

The different approaches of these theories on the organization of grammar can thus be very generally illustrated as in Figures 2 and 3. The idea of a representational network of conceptual semantics was already presented in Figure 1; its ambition is to describe the representations within their own modules. Every module operates with its own primitives and their combinatory links plus the relational connections between the modules, as can be basically outlined as in Figure 2. Figure 3 sketches the bipolar



symbolic space that the cognitive grammar operates within. The arrow with the dashed line indicates that the interface between the poles is not specified but has the character of a continuum:

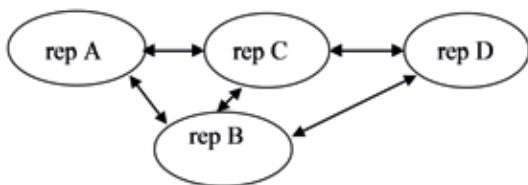

Figure 2. Conceptual semantics and representationality

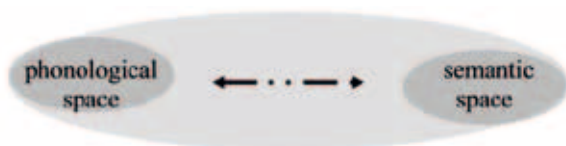

Figure 3. Cognitive grammar and the symbolic space

The vital question in comparing these two approaches is: how does the non-specialised symbolic space help us understand the nature of language? According to the idea of grammar as a continuum, every linguistic phenomenon can be located in an indefinite position in the symbolic space. However, as long as the grades on the continuum are not explicitly specified, this is problematic – the claim is too weak for either verification or falsification. The question is: how exactly can we integrate phenomena like phonology and semantics? What status does the space between them in the continuum have? How can we know that we are approaching one of the poles? In order to develop a workable model from the concept of the continuum, it is important to identify its characteristics using defined attributes. Then the descriptions can be generalised and compared. But is it, in general, possible to place categories with different kinds of primitives in the same continuum?

My opinion is that we must strive to identify the boundaries and features of language, not just for an explanation of its nature but also to identify holes in the boundaries. Thus it seems more efficient to analyse the different levels of grammar explicitly as autonomous systems and on this foundation to study the relations between these levels. Another important argument is that a linguistic model cannot reduce syntax from grammar; the rules of a language that create well-formed sentences should be included in the description. Finally, since the primitive categories of syntax, phonology and semantics are basically distinct, a treatment of them as a level of the same continuum would be a contradiction.

Another linguistic theory that interfaces with conceptual semantics is ‘construction grammar’ (Fillmore, Kay & O’Connor 1988; Goldberg 1995; Fried & Östman 2004; Croft 2001). Construction grammar shares the generative tradition and the basic idea of formalization (though with different methodology). Views on what exactly is meant by the notion of construction and what the general principles are in language (if they are assumed at all) varies in that the conceptual semantics theory assumes the existence of both general (default) rules and irregular mappings of form and meaning (for similarities and differences between construction grammar and conceptual semantics, see Nikanne 2004. I return to these questions in 5.1).

## **2.2 Basic tools of conceptual semantics**

### **2.2.1 Tiers and zones in the conceptual structure**

Sections 2.2.1-2.2.3 outline the basic methodology of conceptual semantics, with an emphasis on the tiernet account. Methodology is examined in chapters 3-5; some details relevant to the analysis of causative verbs are given a more detailed explanation in connection to the actual analysis.

The next step on from ontological categories in aiming at a well-formed conceptual counterpart of a sentence is defining the structure of conceptual constituents. Jackendoff (1990: 23) proposes that each conceptual category is realised by decomposition into a function-argument structure, and each argument is a conceptual constituent of some major category. The relational principle between the syntactic representation of a sentence and conceptual functions is as follows: the lexical head X of a major phrasal constituent corresponds to a function in the conceptual structure, whereas major syntactic phrases correspond to major conceptual constituents (Jackendoff (1983: 63-70, 1990: 13-25). I return to the analysis of syntax-semantic interface in the next section and concentrate here on fragments of the conceptual structure.

The basic operational tools in the analysis of the conceptual representation of a word or the LCS are semantic roles and functions as parts of a multi-tiered structure. The major tiers in the conceptual structure are the ‘thematic tier’ and the ‘action tier’, which operate with thematic roles (agent, theme, location etc.) and action roles (actor and undergoer) (Jackendoff, 1990). The thematic roles of the linguistic components are determined by the well-formedness rules of the conceptual structure. In my study of causative verbs I follow the line of Nikanne, which is slightly different from the organization of conceptual structure of Jackendoff. The main difference between these two approaches is that in Jackendoff’s model the conceptual structure consists of the two abovementioned major tiers, whereas in Nikanne’s tiernet system the thematic tier is assumed to divide into several zones. In Nikanne (1990), the organization of LCS is claimed to be non-linear, meaning that the order of the semantic functions (CAUSE, GO, TO, FROM etc.) is determined by three

‘positional groups’ or ‘zones’. Consequently, the direction in the f-chain (the chain of functions) is always from the causative zone towards the locative zone i.e. from left to right (Nikanne 1990, 1995 & 1997). The organization of the zones and how the thematic tier functions and the thematic roles are divided within it is illustrated in table (1), taken from Nikanne (1997: 83):

Table 1. Zones and semantic functions

<b>ZONE 3</b>	<b>ZONE 2</b>	<b>ZONE 1</b>
<b>Causative zone</b>	<b>Thematic zone</b>	<b>Location zone</b>
Non-monadic functions: CAUSE LET	Non-monadic functions: GO BE	Monadic functions: AT, ON, IN, UNDER etc. (i.e. place functions)
Monadic functions: INCH	STAY EXT	TO, TOWARD, FROM, VIA, AWAY FROM etc. (i.e. path functions)
Thematic role: agent	Monadic functions: CONF MOVE	Thematic role: reference object (location, goal, source, route, recipient etc.)
	Thematic role: theme	

The functions are thus divided into several types as path functions, state functions, event functions and place functions. The functions and their characteristics are described in Nikanne (2002) as follows:

### **Zone 1 functions** (place and path functions)

Place functions:

AT – the general place function; selects the location

ON – on top or above; selects the location

IN – inside or in; selects the location

UNDER – under or below; selects the location etc.

Path functions:

TO – to, up to; selects the goal

TOWARD – to, toward; selects the goal

FROM – from; selects the source

AWAY FROM – from a direction; selects the goal

VIA – through, via; selects the route

### **Zone 2 functions** (non-causative event functions)

GO – changing; selects the theme and one or more path functions

BE – being; selects the theme and one or more place functions

STAY – staying; selects the theme and one or more place functions

ORIENT – directing; selects the theme and one or more path functions

EXT – extending; selects the theme and one or more path functions

CONF – configuration; selects the theme

MOVE – being in some sort of (monotonic) activation; selects the theme

**Zone 3 functions** (causative event functions and the inchoative event function)

CAUSE – causing; selects the causer and a zone 3 or zone 2 function

LET – letting; selects the causer and a zone 3 or zone 2 function

INCH – inchoative; selects the causer and a zone 3 or zone 2 function

The difference between monadic and non-monadic functions is that monadic functions can only select one complement (either another function or an argument) while non-monadic functions can have one or more complement; consider (1) and (2):

(1) *Mary dances.*



(2) *John flew from Helsinki to Rome via Munich.*

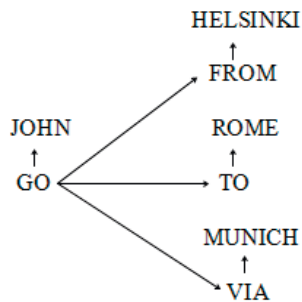

Hence, the basis of the conceptual structure is a chain of functions. The order of this structure is not arbitrary but based on dependency relations between the functions, indicating the connection between the participants in the event. The sequence of semantic functions is called the ‘function chain’ (f-chain), and its combination principle is based on the f-chain schema (3). The number after the f indicates the zone (one, two or three), the arrow indicates selection and the asterisk (\*) after the symbol indicates that there can be none, one or several instances of the function in the f-chain. The f-chain schema thus states that the number of f1s and f3s can vary from none to several, but there must always be one and only one f2 in a well-formed f-chain. Consequently, it can be said that zone 2 is the core zone of the conceptual structure (Nikanne 1990 and later).

(3) The f-chain schema:  $f3^* \rightarrow f2 \rightarrow f1^*$

In the analysis of the thematic structure of a sentence, we insert the concrete function into the f-chain. Each function selects an argument carrying a thematic role. The thematic role hierarchy in the tiernet theory is not a list of roles, but follows directly from the principle of the f-chain (see Nikanne 1997c). An example of the conceptual structure with the verb ‘to send’ is presented in (4):

(4) *Mary sent a letter to John.*

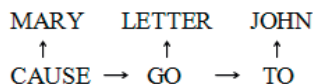

The interpretation of the  $\theta$ -criterion in conceptual semantics is special in that it also allows an implicit argument to have a position in the argument structure. Additionally, it is possible to explicate the multiple thematic roles of a NP by indexing the arguments. A conceptual argument is thus not necessarily expressed in syntax, and even an implicit argument can have more than one role in the conceptual structure (Jackendoff 1990: 44, 55, 59–64). To illustrate the binding of an argument with one syntactic position and multiple theta-roles, consider for instance the reflexive verb *pukeutua* ‘to dress oneself’. The subject argument of this verb is encoded as the causer of activity and additionally as the thing in motion or the theme i.e. one syntactic entity satisfies two distinct conceptual positions. Jackendoff (1990: 63) proposes a notation of argument binding between a binding argument and bound arguments by using Greek letters. A sentence with *pukeutua* can thus be analysed as in (5), where the binder argument, Mary, is notated by the superscript  $\alpha$  and its bindee by a normal size  $\alpha$ . Thus, these arguments are co-referential. An additional remark concerning the marking in this analysis is that the conceptual arguments are marked with block capitals.

(5) *Mary pukeutuu villatakkiin*

Mary dress-refl-pres-3sg gardigan-ill

‘Mary puts on (dresses herself in) a cardigan.’

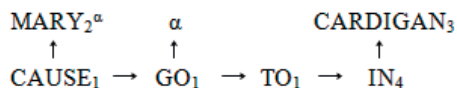

As a tool for marking the argument binding within the conceptual structure, I follow the notation of Jackendoff (1990: 59-64). Following Nikanne's (see e.g. 1997: 87) theory, I mark the implicit arguments with the

superscript index I. The I-marking differs from Jackendoff's (1990) a-marking in that only the implicit arguments are indexed in lexicon whereas the conceptual arguments having a counterpart in syntax are left unindexed. This idea is based on the minimal stipulation account: in order to achieve the most straightforward description, the general linking rule does not need to be marked. We will see that the notion of implicit argument has a crucial role in the conceptual analysis of CSDs. The implicit adessive adjunct phenomenon is discussed in particular in section 3.1.2 as well as in connection with the discussion of the linking patterns of CSD prototypes in 3.3-3.4. See the analysis including implicit arguments in examples (4, 5 & 12) of the next subsection.

In addition to the thematic tier, the conceptual structure consists of an 'action tier' that includes the roles of actor, undergoer, patient and beneficiary. Nikanne (1995) argues, to the contrary of Jackendoff (1990), that syntactico-lexical argument linking is primarily based on the thematic tier and only secondarily on the action tier. The action tier expresses dominance relations between the participants by determining the semantic roles of actor and undergoer for the participants in an event. The actor is the active participant in the event, who is dominating the passive argument of the action tier (the undergoer). Basically, actor and undergoer are roles of human social relations. An argument that carries a semantic role in the thematic tier can thus be assigned another role in the action tier. The action tier functions **AC** (actor) and **UN** (undergoer) form an **act-chain**. The conceptual representation of the sentence 'Mary sent a letter to John' with its action tier functions and thematic tier can be seen in (6).

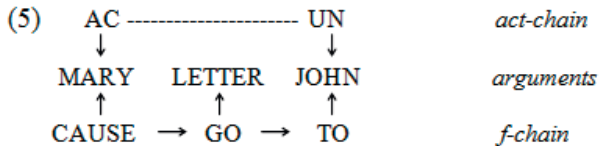

Another separate tier of the conceptual structure is the 'temporal tier' where the internal time dimension of a situation, the actionsart structure, is handled (for the temporal tier see Jackendoff 1990, Nikanne 1990, 1997b & 2008 and Pörn 2004). The primitives of the temporal tier are **P** (point of time) and **R** (region of time). Nikanne emphasizes that if a situation includes R, it has a (directional) temporal lasting; P indicates that a situation has no temporal lasting. Thus, R signifies that a situation is a process. The point of time is a zero-dimensional entity; therefore, it can be visualized as a point. The region of time is a one-dimensional entity and can be pictured as a line:

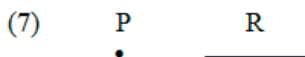

The temporal tier can be segmented further into the following combinations:

- (8)  $R \rightarrow RPR$   
 $P \rightarrow PRP$   
 $P \rightarrow RP$   
 $P \rightarrow PR$

When associating the temporal tier and action tier of the sentence ‘Mary sent a letter to John’ in the conceptual structure, we get the following configuration:

(9)

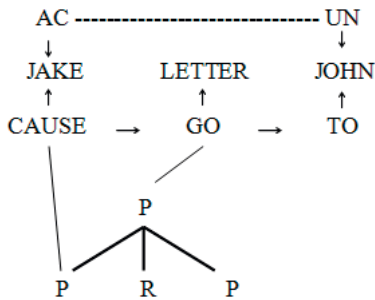

The action and temporal tiers in connection with CSDs are discussed in detail in chapter 4.

A further level of description of the conceptual structure is the ‘semantic field tier’. Whereas the action tier and the thematic tier handle the participants in the situation and the relations between them, the semantic field tier adds the description of the cognitive backgrounds in which the events take place. According to the localist hypothesis, all kinds of expressions (temporal, possessive etc.) can be derived from spatial ones (Gruber 1965 & 1970, Jackendoff 1983, Miller 1985), which is one of the leading ideas of conceptual semantics. This idea is captured in the thematic relations hypothesis (Jackendoff 1983: 188):

In any semantic field of [EVENTS] and [STATES], the principal event, state, path, and place functions are a subset of those used for the analysis of spatial location and motion. Fields differ in three possible ways:

- a. what kind of entities may appear as themes;
- b. what kind of entities may appear as reference objects;
- c. what kind of relation assumes the role played by location in the field of spatial expressions.

In Jackendoff’s rule system, the separate but analogous function systems are based on the semantic fields. Nikanne’s (1990) description of the

combinations of thematic functions and semantic fields differs in that the semantic fields are allocated to a tier of their own. According to the localist tradition, the spatial semantic field is unmarked; therefore it is not obligatory to add it to the description (see Jackendoff 1983: 188; Nikanne 1990: 23-25). Nikanne (2002) assumes that the cognitive area of a linguistic expression is determined in zone 1, and that the semantic properties of zone 1 spread to zone 2. These zones thus have a shared semantic field. The semantic fields, based on the fields suggested in Jackendoff (1983: 188-203), of the core zones are, according to Nikanne (1990: 23-25, 2002), the following:

- The spatial semantic field, the background of which is a concrete situation and its changes
- The possessive semantic field, expressing a possessive relation such as possession, part-whole relation and social agreement
- The temporal semantic field, expressing the temporal location and its changes
- The circumstantial semantic field, describing a situational background
- The characterizing semantic field, expressing a feature or typifying something

The semantic fields of zone 3 are, according to Nikanne (2002), based on the nature of causation; these are not dependent on the semantic fields of the core zones. The causation can be described for instance in physical, social or magic semantic fields. The LCS of the sentence 'Jake carries the desk into the house' with semantic fields looks like this (10):

(10)

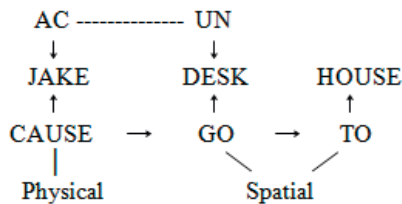

The causer argument JAKE selected by the cause function assigns the role actor in the action tier. The theme DESK<sup>11</sup> that is characterized by a transition (assigned by the function GO). At the action tier level, the activity of the actor (AC) is directed at the theme argument. This means that the argument DESK assigns the role undergoer (UN) in the action tier. In the example (10), causation is happening in the physical semantic field, and the transition of the theme is described in the spatial semantic field.

<sup>11</sup> The thematic arguments are marked with capital letters.



In Nikanne (1987, 1990 & 2006), the semantic functions are analysed further as feature systems. The features relevant to this study are the following:

- T Time-related, indicating that the event has an internal time line
- b Bound, indicating that a path or event is bound
- D Directed, indicating that an event has a direction
- gl Goal, a path feature indicating the end of a path (sub-feature of D)
- so Source, a path feature indicating the beginning of the path (sub-feature of D)
- ro Route, a path feature indicating a relevant mid-point of the path (sub-feature of D)

The f-chain of the sentence analysed in (10), ‘Jake carried the desk into the house’, with its features and theta-arguments then appears as we see it in (11). The analysis in (11) reflects the temporal, directional and telicity features of the sentence. There are two events with an internal time line (marked as T). As the f-chain of (11) is bound in all possible places (i.e. both events are marked as b), it is a telic situation (for more on events being bound, see Jackendoff 1991, Nikanne 2006).

(11)

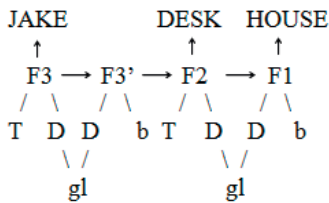

If there is a zone 3, the monadic zone 3 function (marked as f3' in (11)) at the boundary of zone 2 and zone 3 is mandatory because of the presence of the D-features. Monadic f3 functions are not able to assign a theta role like dyadic functions, f1s and monadic f2s do.

An important consequence of the notion of the nonlinear thematic structure on conceptual semantics is that it is now possible to treat the semantic structure in terms of dependence rules. This is different compared to the Jackendovian variant of conceptual structure which describes the constituency relations within conceptual structure. The f-chain is thus a headed structure; it assigns a thematic role to the arguments and the arguments are then assigned act-roles. The scope of the head-complement relations is from left to right and from the f-chain to the thematic arguments.

### 2.2.2. Linking of syntactic, semantic and morphological arguments

One of the central research subjects within conceptual semantics is the interface between syntactic and semantic representations. The assumption is that a proper description of the lexical conceptual structure of a sentence should enable a specification of the mapping principles between the conceptual and syntactic levels. The basic principle is that every sentential constituent corresponds to a conceptual constituent; the thematic role is visible as a structural argument position with conceptual content. The correspondence between the conceptual structure and the syntactic categories is not arbitrary: there are certain regularities determining the mapping. According to Nikanne (1998a: 311), the unmarked linking relation between LCSs and syntactic categories is that given in (1):

- (1) a. A word whose LCS is based on a piece of f-chain is syntactically a V or P.  
 b. A word whose LCS only contains f1s is syntactically a P.  
 c. A word whose LCS contains an f2 and/or a non-monadic f3 is a V.

The principles of (1) are illustrated in example (2). The numeral indices indicate the correspondence relations between the syntactic and conceptual constituents.

- (2) *Mary<sub>2</sub> sent<sub>1</sub> a letter<sub>3</sub> to<sub>4</sub> John<sub>5</sub>.*

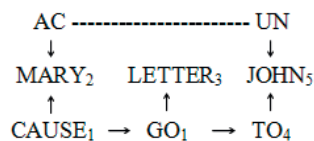

The general principle of linking between the grammatical functions and the thematic arguments is that the thematic arguments in a conceptual structure correspond to the thematic role carriers in syntax, and the f-chain corresponds to syntactic predicates (Jackendoff (1983: 67, Nikanne 1998a: 311). Nikanne (1997; compare with Jackendoff 1990) argues that the thematic arguments are not directly linked to syntax but via an intermediate level that determines the ‘subject argument’ and ‘object argument’ of the sentence. This system is the ‘direct argument system’ (the DA system), suggesting that syntactic argument places are derived in the lexicon, or more precisely in the lexical conceptual structure of a word. The assumption behind the intermediate linking level is that it accounts for different forms of linking, implying that linking relations do not follow the one-to-one linking principle. The categories with which the DA level operates are the following:

DA1: first argument, ‘logical subject’  
 DA2: second argument, ‘logical object’

The notions DA1 and DA2 are primitive categories – they cannot be reduced to any thematic hierarchy because of numerous exceptions. According to Nikanne (1997 & 2002), the rules that govern the DA derivation are the following:

- (3) 1. Every thematic argument selected by the lexical function-chain is a potential DA.
2. An implicit argument cannot be a potential DA.
3. The potential DAs are ordered from left to right as DA1 and DA2.

A benefit of this system is that it enables us, for instance, to separate the default cases of argument-linking from exceptional ones. For example, we can analyse the lexical argument linking of the English verb ‘to paint’. The word means ‘to apply colour or paint onto something’: the lexical entry of it is presented in (4). The structure in (5) describes the linking relations between the syntactic structure and the LCS of ‘to paint’. The link between conceptual arguments and DAs is marked with a single line, and the link between syntax and conceptual structure is indicated by a dotted line. The causer argument MARY is the leftmost argument and is linked to DA1. Because the theme argument is an implicit argument PAINT<sup>I</sup>, it cannot assign DA status. Instead, the goal HOUSE is selected as DA2.

(4) The lexical entry of ‘to paint’:

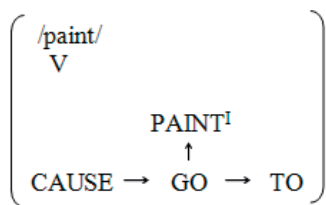

(5) *Mary paints the house.*

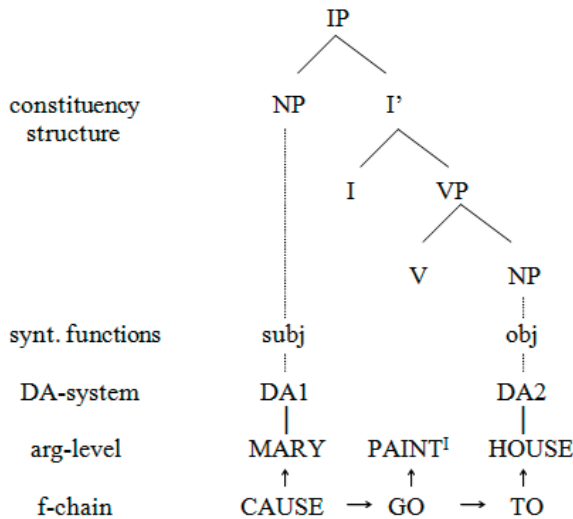

In an analysis of causative derivatives, the root verb arguments have an important role (see the discussion in (1.2)). Therefore, I suggest that in analysis of derived causative verbs, there is good reason to analyse an additional intermediate argument level in addition to the DA system between syntax and lexicon: the ‘morpholexical level’. I thus assume a subsystem of lexically derived arguments – ‘morphological roles’ – for the analysis of deverbal verbs in the following terms:

- SAD – Subject argument of derived causative verb
- SAR – Subject argument of root verb
- OAR – Object argument of root verb

Example (6) is a sentence with a CSD, *haetuttaa* ‘make s.o. fetch’, derived from the causative base verb *hakea* ‘to fetch’. The CSD of the sentence in (7), *juoksuttaa* ‘make s.o. run’, is an example of the causative with a non-causative root verb. I have marked the morphoroles above the sentences.

- |     |  |                     |                |               |                     |
|-----|--|---------------------|----------------|---------------|---------------------|
|     | SAD  |                     | SAR            | OAR           |                     |
| (6) |  |                     |                |               |                     |
|     | <i>Maija</i>                                       | <i>haetuttaa</i>    | <i>Matilla</i> | <i>kirjan</i> | <i>kirjastosta.</i> |
|     | Maija  | fetch-caus-pres-3sg | Matti-ade      | book-acc      | library-ela         |
|     | ‘Maija had Matti fetch the book from the library.’ |                     |                |               |                     |

- (7)
- |       |                   |           |          |
|-------|-------------------|-----------|----------|
| SAD   |                   | SAR       |          |
|       |                   |           |          |
| Maija | juoksuttaa        | Matti     | kauppaan |
| Maija | run-caus-pres-3sg | Matti-acc | shop-ill |
- ‘Maija had Matti run to the shop.’

The benefit of the morphoroles in argument structure analysis becomes evident by linking them to the DA system. Consider examples (8) and (9), explicating two distinct linking configurations: the DA2 argument of CSDs can be linked to the OAR (8) or SAR (9).

- (8)
- |       |                     |           |          |              |
|-------|---------------------|-----------|----------|--------------|
| DA1   |                     | DA2       |          |              |
|       |                     |           | OAR      |              |
| SAD   |                     | SAR       |          |              |
|       |                     |           |          |              |
| Maija | haetuttaa           | Matti     | kirjan   | kirjastosta. |
| Maija | fetch-caus-pres-3sg | Matti-ade | book-acc | library-ela  |
- ‘Maija had Matti fetch the book from the library.’

- (9)
- |       |                   |           |          |
|-------|-------------------|-----------|----------|
| DA1   |                   | DA2       |          |
|       |                   |           |          |
| SAD   |                   | SAR       |          |
|       |                   |           |          |
| Maija | juoksuttaa        | Matti     | kauppaan |
| Maija | run-caus-pres-3sg | Matti-acc | shop-ill |
- ‘Maija had Matti run to the shop.’

As a preliminary hypothesis, I assume that the morpholexical DA-linking of CSDs depends on the syntactic-semantic nature of the root verb. I assume that depending on the *causativity* of the root verb, the linking is in default cases as in (10) or (11). The causative suffix *ttA* thus adds a new subject to the argument structure (SAD). The difference between derivatives according to their root verb causativity finds expression in the linking of the SAR: the SAR of a CSD derived from a causative root verb (compare with example (6)) governs an adjunct marked with the adessive case, whereas the SAR of a CSD derived from a non-causative root verb (compare with example (7)) is expressed in syntax as an object (DA2).

- (10)
- |   |     |     |  |   |     |
|---|-----|-----|--|---|-----|
| Adjunct   | DA2 | DA1 |  | DA2   | DA1 |
| ↑   | ↑   | ↑   |  | ↑   | ↑   |
| SAR   | OAR | SAD |  | SAR   | SAD |
| ↑   | ↑   | ↑   |  | ↑   | ↑   |
| [v [v causative] <sub>j</sub> ttA] <sub>i</sub> |     |     |  | [v [v non-causative] <sub>j</sub> ttA] <sub>i</sub> |     |
- (11)

In the case of morphological causatives, it is justified to describe the DA system in two tiers for (at least) two reasons. Firstly, in the case of derived verbs, morpholexical linking allows us to explicate the mapping relations between syntax and lexicon. Although the derivatives belong to the lexicon, the syntax of the root verb is significant in the behaviour of the derivatives. Using morphological roles facilitates differentiation between the arguments of the root verb and those of the derivation, as it allows us to observe the status of the arguments of the root verb in the derivative structure. The second benefit of using the morphoroles is the possibility to describe their mapping onto the thematic roles (causer, theme, reference object etc.) of the derivative. The morphoroles thus enable us to keep the roles of different levels apart; the SAR is expressed as an adessive adjunct in syntax when appearing as the causer in the CS and as object when assigning the thematic role theme<sup>12</sup>. The discussion in chapter 3 concentrates in particular on the linking relations between the syntactic and CS levels of the CSDs. The mapping of the morphoroles onto the thematic roles is also the focus of chapters 5-6. As a preliminary assumption, the relation of morphoroles to the DAs of the derivative and its root can be described in the following way:

SAD – Subject argument of derived causative verb	}	DA1 and DA2 of derivative
OAD – Object argument of derivative		
SAR – Subject argument of root verb	}	DA1 and DA2 of root verb
OAR – Object argument of root verb		

Hence, by adding the morpholexical level to the description, we become aware of the argument structure of the root verb and its influence on the derivative structure – like the DA-system, the morphorole system also operates within a lexical item. I will illustrate the syntactico-lexical linking system of the CSD *maalauttaa* ‘make s.o. paint’ using a similar analysis of the different levels as the analysis of ‘to paint’ in (3). The structure in (12) reflects the LCS of *maalauttaa*: the left-most argument is JANE, selected by the first cause-function and will be DA1. As the argument MARY<sup>1</sup> is the implicit adjunct, it cannot assign the DA status, as well as the implicit theme argument (PAINT<sup>1</sup>) (the nature of implicit arguments is given closer attention in section 3.1.2 in connection to the adessive adjunct discussion). The next thematic argument from left to right is the goal HOUSE, selected as DA2.

<sup>12</sup> For this reason, the CSDs cannot, for example, be called ‘double-agentive causatives’.

- (12) *Jane maalauttaa talon Marylla*  
 Jane paint-caus-pres-3sg house-acc Mary-ade  
 ‘Jane had Mary paint the house.’

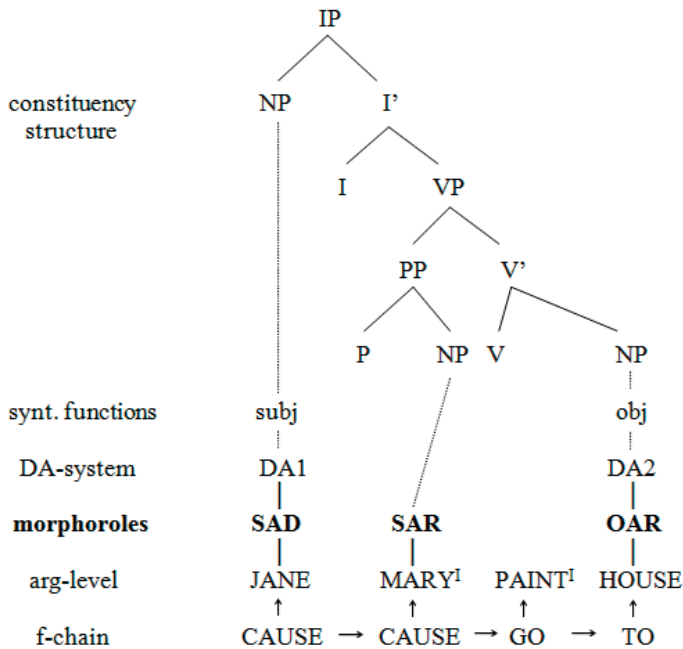

I expect the analysis of the CSDs in chapters 3-5 to answer the following questions: What is the status of the SAR and OAR in the derivative structure? Are there exceptions in the default linking? This is a central theme of the thesis, as I operate with morphoroles throughout the study.

### 2.2.3 Architecture of the tiernet model

After the presentation of the basic methodological tools of conceptual semantics, this section will focus on the tiernet model approach. The status of the levels discussed in sections 2.2.1-2.2.2 for the present study will be explained i.e. how the representations are related to each other and what the relevant components for the research subject are. The tiernet organization of micromodules based on the formation of Finnish grammar is described in Nikanne (2002 & 2006) as in Figure 2. The solid lines indicate stronger and the dashed lines weaker links between the modules. Modules like syntactic functions, word order, constituency and dependency belong to syntax. Stress, syllables, timing and melody are modules of phonology. Action functions, thematic functions, thematic features, action chain, f-chain and modal tier form parts of conceptual structure. This model differs from the Jackendovian

organization of grammar (see section 2.1 above) in that it treats morphology as a separate module; this is especially relevant for a language like Finnish as morphology is an essential part of its grammar. The lexicon, constructions and morphology components are, in this organization, understood as modules without primitives and rules of combination of their own; they are part of the linking system (the units of these modules are built from fragments of other modules). Hence, the lexicon, constructions and morphology are linking devices mapping together phonological, syntactic and semantic information. These components consist of ‘frozen’ links between the tiers and the relations between the freezes; also, grammaticalization and lexicalization are analysed as freezes in this model.

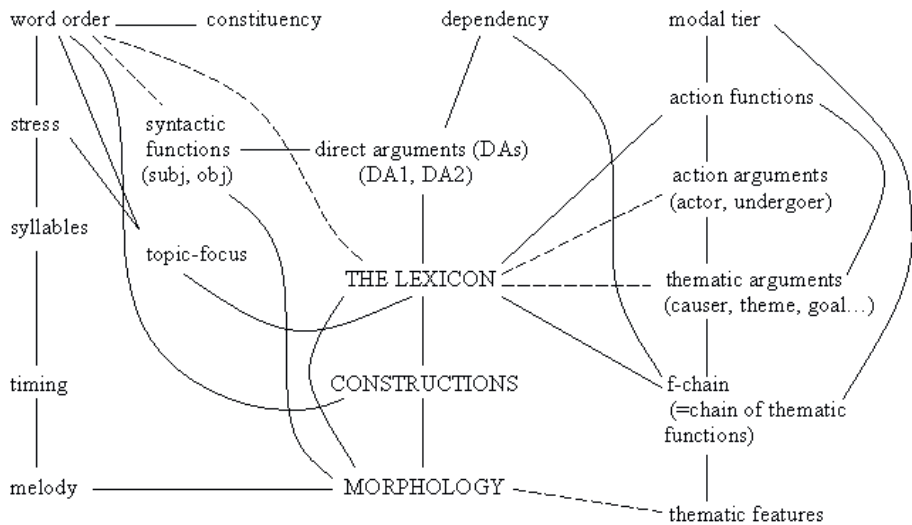

Figure 2. The micromodules relevant to Finnish grammar (Nikanne 2002 and 2006: 220)

As seen in Figure 2, big modules are divided into smaller units of phonology, syntax and conceptual structure. The tier-net model differs from the Jackendoffian approach in that it is an open system – different languages may use different tiers and different linking regularities. The structures and mappings are kept as simple as possible; the links may also be stronger or weaker, which brings the approach closer to the connectionist point of view. The main advantage of the tier-net model is that it facilitates the outlining of relationships between lexicon, constructions and morphology. Note that the viewpoint on constructions as a separate module differs from the Jackendoffian approach, in which constructions are considered part of the lexicon (as is assumed for instance in Jackendoff 1997).



This study of causative derivatives concentrates primarily on the centre and right side of the outlining in Figure 2. All of the linking system modules, the lexicon, constructions and morphology are relevant for the analysis of CSDs. The causative derivatives are considered in this study as part of lexicon, sharing certain morphological, syntactic and semantic information; the interaction between these levels is the central topic. Additionally, the constructions module is also discussed. Syntax of CSDs is handled through the argument structure of these verbs and the links to the direct argument (DA) level. Although I treat CSDs as part of the lexicon, I take into consideration the effect of the syntax of the base verb on the behaviour of the derivatives. For a more exact analysis of the linking relation between the syntactic arguments of the root verb and the arguments of the derivative, I add a new level to the modular system, the ‘morpholexical linking system’. I argue that the syntactic behaviour of the CSDs is determined by the links to the morphorole module. In addition to the linking system, the main focus is on the conceptual structure. In the analysis of the lexical conceptual structure of CSDs, central modules are the thematic tier and the action tier levels. Modules like f-chain and action functions are directly derived from the lexicon (see Nikanne 1995 & 1998a).

I assume a separate module for aspects related to social dimension, which is in line with the idea of Jackendoff (1992a) of a social representation in the organization of conceptual structure (this idea is presented in section 5.1). Considering the significance of social conceptualization on the semantics of CSDs, I focus especially on the social dimension. I assume the social understanding module as an interactive representation built on the conceptual structure information and connected through its micromodules with lexicon, constructions and morphology; the social module can thus be regarded as a linking system module, similar to lexicon, constructions and morphology. The parts of grammar relevant for this study are presented in Figure 3.

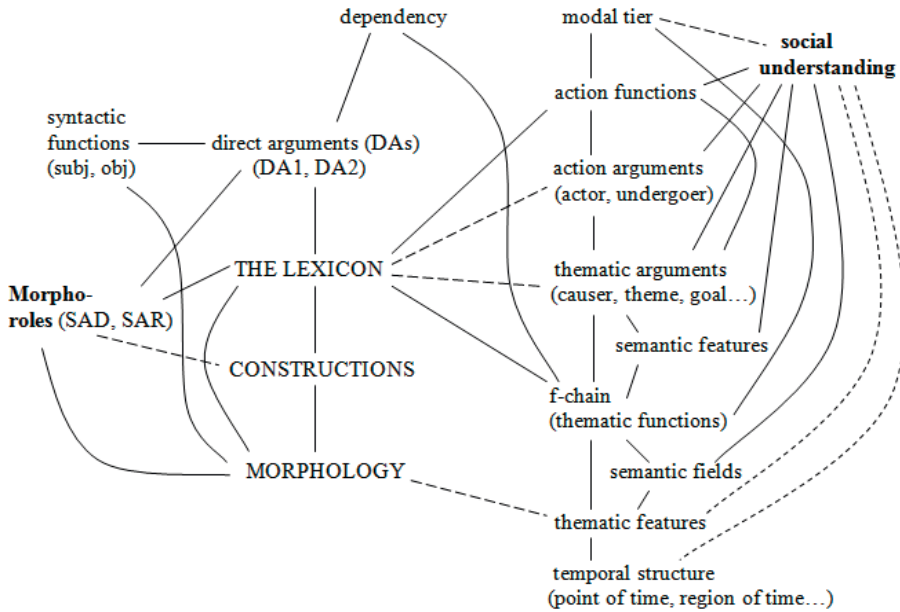

Figure 3. The modules relevant to the study of causative verbs of social dominance

This image includes some modules that are not specified in Nikanne's outlining of Finnish grammar (compare to Figure 2). An addition is the temporal tier; part of this study examines the effect of temporal relations on causation, in chapter 4. The second insertion is the semantic field tier; this area is discussed in connection with CSD constructions in particular in chapter 5. Also (privative) semantic features like control, consciousness, volitionality etc. form part of the description. I have added the morphological level that has not been given the explicit status of independent modules, and social understanding as a separate module. The central topic of my study is clarification of the nature of the linking rules between modules relevant to CSDs. The linking system is also important in the case of the constructions module: by identifying the regular linking, we can detect cases where the linking system does not function according to assumptions. The regular linking means here that the interaction between the subsystems described in figures 2 and 3 follows general principles, such as argument selection rules<sup>13</sup>.

The social understanding module is understood as a dimension characteristic of human social interaction – responsibility, dominance, moral norms etc. Social dimensions are connected to the conceptual structure representations like action functions, action arguments, thematic arguments,

<sup>13</sup>A discussion about the methodological advantages of keeping regular and irregular linking with a specified linking nature apart can be found in Nikanne 2005.

thematic features and semantic features. These levels are significant for construction building; the discussion of the causative constructions in chapter 5 involves modules like action tier, temporal tier, thematic tier, semantic field tier, thematic and semantic features; these are important links that affect construction building via lexicon. I argue that the variations in social conceptualization play a role in the clustering of CSDs and are also a source of such pragmatic implications as expressing attitudes.

## 2.3 Material and methods

### 2.3.1 Structured vs. non-structured language corpora

The goal of this study is to give a formal lexical description of causatives of social dominance and to examine the morpho-syntactic, semantic and even pragmatic aspects related to these derivatives. Therefore, it is important to investigate these verbs in usage in addition to introspective lexical analysis. Which verbs are most appropriate as the subject of analysis and where do they occur? As discussed in section 1.2, causative verb derivation is generally not regarded to be restricted by structural limitations; therefore, the possible root verb scale of CSDs is large. The discussion on the criteria of curative causatives explained the shift of perspective that the introduction of the term ‘causative derivatives of social dominance’ implies. The notion of CSD thus extends the scope of the research subject. The present approach involves verbs that may satisfy some of the requirements of curative causatives, but not all, as well as verbs that would be separated by restrictions, such as *jonotuttaa* ‘make s.o. queue’ (derived from a non-active root verb), *kyykyyttää* ‘make s.o. squat’ (a denominal causative) or *otteluttaa* ‘make s.o. compete’ (derived from an intransitive root verb). Because the aim of this study is to investigate the encoding of human social relations expressed by *ttA*-causatives, I consider these verbs as relevant to the analysis. In this section I discuss the sources of my material in more detail; the verbs selected for the analysis are presented in the next section (2.3.2).

In addition to the formal account of causatives of social dominance, my goal is to study the behaviour of these verbs in context. For this purpose, it has been necessary to clarify the kind of language use in which CSDs appear and how they can be retrieved from large materials. A CSD represents a complex combination of morphological, syntactic and semantic features. In her study of curative causatives, Kytömäki (1989: 71-74) suggests that because of their compactness, these verbs are a phenomenon of formal written language, well suited to newspaper headline language. According to her, the complex synthetic forms do not form part of colloquial language, and analytical paraphrases are used instead of derivatives in less restricted informal language use. An example of a periphrastic causative construction is presented in (1a) and the corresponding morphological causative in (1b):

- (1a) *Matti antaa Pekan rakentaa talon*  
 Matti let-pres-3sg Pekka-acc build-infl house-acc  
 ‘Matti makes Pekka build the house.’
- (1b) *Matti rakennuttaa Pekalla talon*  
 Matti build-cause-pres-3sg Pekka-ade house-acc  
 ‘Matti makes Pekka build the house.’

The language usage data of this study is generally collected from two sources: the text corpus of written Finnish, the Language Bank of Finland (Kielipankki)<sup>14</sup> and a corpus based on the material I have collected from the Internet. The Language Bank is the largest electronic corpus on Finnish, covering approximately 130 million running words, mostly from periodical texts. On the basis of comparison of the materials extracted from newspaper text corpora and the online data from various textual sources, I would argue that the genre estimation of CSDs referred to above does not fully hold. Using a CSD is without doubt an excellent way of obtaining compact, felicitous and attention-grabbing headlines, as the examples below show:

- (2a) *The Prodigy tanssitti jälleen*  
 The prodigy dance-caus-past-3sg again  
 ‘The Prodigy made [the public] dance again.’  
 (<http://www.hs.fi/kulttuuri/konsertti/artikkeli/The+Prodigy+tanssitti+j%C3%A4lleen/HS20091114SI1KU04a37>, 14.11.2009)
- (2b) *Poliisi puhallutti jälleen rattijuopon Soinissa*  
 police blow-caus-past-3sg wheel.drinker-acc Soini-ine  
 ‘The police made a drunk driver blow (take a breath test) again in Soini.’ (<http://www.jpnews.fi>, 17.10.2009)

However, my observations based on authentic data indicate that *ttA*-causatives corresponding to the prototype structures of CSDs (which are discussed in section 2.4) also function well in more colloquial language surroundings. Furthermore, I would argue that these derivatives are an idiomatic and vital part of the Finnish language, especially in the contexts of freer and creative language use. This observation is based in particular on the data collected from websites, such as online conversations. Nor does the

<sup>14</sup> The Language Bank of Finland is a language corpus developed by CSC, the Finnish IT centre for science (Tieteen tietotekniikan keskus). In my research I have used The Finnish Language Text Collection (*Suomen kielen tekstikokoelma*), a selection of electronic research material that contains written Finnish from the 1990s. I have used *www-Lemmi* 2.0 as the web-based tool in the corpus work in the lexical database of the Language Bank of Finland. The corpus is available via the CSC at the following address:  
[http://www.csc.fi/english/research/sciences/linguistics/index\\_html](http://www.csc.fi/english/research/sciences/linguistics/index_html).

structural and semantic complexity of CSDs seem to inhibit the use of these derivatives in informal, spontaneous language surroundings such as discussion platforms. In fact, the main reason for turning to Internet material is that the traditional text corpora do not provide sufficient sources of CSDs.

This argument can be explained using an example of the CSD *haetuttaa* ‘make s.o. fetch’, a verb that is established as a dictionary entry in the NS. This CSD returns only 11 hits of all its conjugational forms in the corpus of the Language Bank. The query of the 3rd person singular form *haetuttaa*<sup>15</sup> of this verb returns 388 hits (searched on all websites on 13 March 2007) on Google, a search engine for use in finding resources on the World Wide Web, and 22 hits merely from Google discussion groups. The Google results reveal extensions of the meaning of *haetuttaa*, as ‘let seek’ and ‘seek out’ that the Language bank examples do not include (see section 5.3.4 for a more detailed discussion). I have also turned in search of CSDs to the Corpus of Finnish Literary Classics<sup>16</sup> with poor results; for instance, queries regarding the verb *haetuttaa* did not return any hits in this corpus. The use of Internet data has thus been necessary to produce a concept of these verbs in authentic surroundings.

For an illustration of the distributional differences between the language material sources, consider some examples of the verb *kyykyttää* ‘make s.o. squat’. In the Language Bank material, it is merely used in texts with politics as the subject matter, whereas in online material, *kyykyttää* appears in several other contexts (the settings of this verb are presented in more detail in section 5.2.4.2). The verb *kyykyttää* is in frequent use in Internet discussion arenas, such as Google Groups. There were 336 hits alone with the word form *kyykyttää* (standing for the 3<sup>rd</sup> person singular in the present and the 1<sup>st</sup> infinitive form) in all *sfnet* groups, searched on 8 August 2006. This CSD is used within different interest groups, for instance by information technology, sports and motorcycle enthusiasts, or by people discussing their military experiences. Consider the examples (3a-e) of the verb *kyykyttää*. Example (3a) is one of the 40 occurrences of this verb in the Language Bank, representing the use of *kyykyttää* in political discourse. Examples (2b-e) are taken from Google Groups discussions. Both (3b) and (3c) are from a discussion group concerning national defence (*maanpuolustus*). Example (3d) is from a group discussing information technology (*atk.laitteet*) and (3e) is from a discussion among a motorcycle enthusiast group (*harrastus.mp*). The translations of *kyykyttää* are marked with bold typeface; the meaning of this verb can be identified as ‘snooker, suppress; crush’. Note that example (3e) is

<sup>15</sup> In the case of *haetuttaa* ‘make s.o. fetch’, the 3<sup>rd</sup> person singular form in the present is equivalent to the 1<sup>st</sup> infinitive form.

<sup>16</sup> Corpus of Finnish Literary Classics (*Suomalaisen kirjallisuuden klassikoita*) is available via the freely accessible online data service *Kaino* on the site of the Research Institute for the Languages of Finland <http://www.kotus.fi>. The corpus consists of works by established Finnish authors from the 19<sup>th</sup> century to the 1930s.

an exception in that it lacks the causation element: it can be interpreted as ‘being in a particular spatial configuration (squat) while driving a particularly efficient motorbike’<sup>17</sup> among the motorbike enthusiasts.

- (3a) *Heräähän kysymys, onko aivan tieteen tahtoon haluttu **kyykyttää** niitä ihmisiä, joiden tärkeänä palkkatyönä on auttaa todella avun tarpeessa olevia?* (Corpus: demari1998)  
 ‘The question that arises is if the people performing this important assignment so as to help those that really could do with help are intentionally being made to squat?’
- (3b) *Viimeksi Irakissa 1991 nähtiin, että melko kattavakin ilmatorjunta **kyykytetään** nopeasti, jos ilmavoimat eivät tee mitään.*  
 (sfnet.keskustelu.maanpuolustus: Ilmavoimat myyntiin. Mar 12005)  
 ‘Last time in Iraq in 1991 it was shown that even quite extensive anti-aircraft defence can quickly **be overcome** if the aircraft do not do anything.’
- (3c) *Legendoja kuulin myös vartiontihommista olevasta tähtialikessusta, joka **kyykytti** varusmiesjohtajia (myös kokelaita) siitä, että eivät puhutelleet häntä "rouva alikersantiksi".*  
 (sfnet.keskustelu.maanpuolustus: Varusmies vs. kapiainen. Oct 12 2003)  
 ‘I also heard stories about a star corporal in a guarding job that **bossed** the head conscripts (as well as the cadets) **around** because they did not address him as “Mrs corporal”.’
- (3d) *Rinnakkaisporttimalli on hieman hitaampi, mutta tätäkin pahempi ongelma on sen aiheuttama kuormitus – rinnakkaisportti-liitäntäiset laitteet **kyykyttävät** nopeankin koneen täysin.*  
 (sfnet.atk.laitteet.pc: HP 7200e. Sep 5 1998)  
 ‘The parallel portal type is a bit slower, but an even worse problem is the load it causes – parallel portal accessory appliances totally **trash** even a faster machine.’
- (3e) *Hyvä ja ongelmaton joka paikan peruspyörä, halpa pitää ja hoitaa mutta moderneimpiin nähden hieman painavampi (=tukevampi) ja rauhallisempi. CB sopii sille joka ei jaksa enää **kyykyttää**, jolle seuraaviin valoihin ulvottaminen tuntuu lapselliselta ja jolle tehdas-*

<sup>17</sup>This particular meaning of *kyykyttää* ‘make s.o. squat’ is a term used by motorbike enthusiasts; according to a personal conversation with members of this group, the joke in (3e) lies in the ambiguity of this word in this particular context: by driving a *kyykykyyrö* in the squatting position, you can humiliate slower bikers. The word *kyykykyyrö* [squat.bike] stands for particularly efficient motorbikes (for instance the Honda CBR900RR) – as a rule, the greater the squatting position the bike demands of its driver, the faster it is.

*customien ajoasennon rasittavuus reissussa on käynyt selville.*

(sfnet.harrastus.mp: Käyttökokemuksia? Jan 30 2002)

‘A good and trouble-free all-terrain basic cycle, cheap to use and take care of, but a bit sturdier and more stable compared to more modern cycles. CB suits those who don’t have the patience **to squat**, who feel childish about screaming till the next set of lights and who have discovered the strenuousness of the factory-setting driving position for themselves.’

My material indicates that a CSD may occur in various genres, which also confirms the heterogeneity of these verbs from the (con)textual perspective. However, many of the more occasional CSDs, such as *kannatuttaa* [carry-caus-caus] ‘make s.o. carry’, *syötäyttää* [eat-caus-caus-caus] ‘make s.o. eat’ and *piirustuttaa* [draw-caus] ‘make s.o. draw’, which are part of the material I retrieved from the Internet, do not occur in the Language Bank at all, apparently because of the restrictive effect of the text type on the vocabulary. Because the use of CSDs is not limited to a certain genre, it is justified to vary the sources of data. By confining myself to Language Bank material only, the overall picture of the use and semantics for instance of the verb *kyykyttää* ‘make s.o. squat’ would be restricted to ‘put sb at a disadvantage’. Although traditional text corpora are compiled with the goal of providing a representative sample of language, in respect to CSDs these corpora seem not to be representative enough. Hence, even the large text corpora that are available do not necessarily contain occurrences of all linguistic phenomena if the text type, genre or topic do not correspond to the distribution of the research in which the subject appears. Therefore, it makes sense to vary the textual sources for a more extensive description of these verbs. As a source of data, both structured and non-structured corpora have their place in language description.

As a non-structured data source, it is argued that the Internet can, in the absence of representative corpora of modern colloquial Finnish, be seen as the best source of contemporary use of language (Nenonen 2007; for the advantages of the Internet as a corpus in idiom variation study, see Petrova 2010). As a source of written language use, Internet material differs from traditional text corpora in several aspects. It can be defined as a non-structured corpus consisting of miscellaneous sources of texts: articles from newspapers and magazines, threads of discussion groups, blogs, homepages and so on. In addition to the large range of different text types, the content of the Internet is dynamic and constantly changing. As Hoffman (2007) points out, online search results cannot always be reliably replicated, and frequency counts (for instance in relation to text linguistic categories) are not available. Due to this, assignment of text types, genres, registers and writing styles as well as calculation of the frequency of Internet data is a more complex task. Another problematic issue is the fact that the background of the writer as a

language producer is difficult to label or evaluate: there is no certainty even of the nationality of the writer in respect to whether they are a native speaker of the language in question. Also, the standard of the language varies to a high degree. Structured corpora typically consist of texts produced by professional writers, which may lead to a situation where a certain writer's personal style dominates the material. Naturally, even in traditional written language there is a variety from informal to formal genres. This variation is particularly visible on the Internet; additionally, novel genres and language use appear in particular within dialogic communication.

Generally, there are several ways of restricting heterogeneous material when working with the Internet for linguistic purposes. One solution is to develop criteria to filter non-relevant results from relevant ones. A large amount of material can be limited, for instance, by studying a sample of returned hits only, which restricts the amount of results so that it is possible to manually analyse the sample. Then a quantitative analysis can be made. This is exemplified in sections 5.2.1 and 5.2.4.2; in order to outline a rough distribution of verb meaning, I analyse the first 100 hits on Google of the verbs *juoksuttaa* 'make s.o. run' and *kyykittää* 'make s.o. squat'. Another possibility is to select a subsection of online texts for a closer examination or to restrict the material based on temporal criteria etc. This makes it easier to sort the material, especially if the goal is to carry out statistical assessment.

A subject for consideration related to Internet material is the problem of frequency. A simple search on Google returns a number of non-parsed hits of a word. A Google query does not specify the structural or semantic features of an expression, which leads to low precision of results and irrelevant tokens. Hence, the researcher must know exactly which linguistic form they are looking for. What does the number of hits on Google indicate and how can you relate to it? How significant are Internet frequency numbers? The term 'hit' in Internet searches is to some extent misleading – sometimes the example is there but not available or the same example is repeated several times. The word may also have a form that has equivalents in other languages. Nevertheless, even the material of a structured corpus like the Language Bank is not completely problem-free or straightforward. For instance, from the 40 Language Bank corpus results returning the verb *kyykittää* 'make s.o. squat', six are quotations of the same utterance in different newspapers – so are there 40 results or just 35? How do certain journalists' idiolects dominate material? Thus, in calculations of both types of data we need to considerate the factors affecting the linguistic material.

When dealing with online material, we encounter the question of 'creative language use'. How many occurrences of a new lexeme should there be before it 'exists', and in which genres? When should a word be included in a dictionary? Does high frequency equal grammaticality? Due to the productivity of CSDs, many of them are not found in dictionaries. When it comes to the curative causatives discussed in the previous section, Finnish



linguists regard the curative derivation as a nearly conjugation-like process that does not belong in dictionaries; only the derivatives that are lexicalized have a dictionary entry (see e.g. Kangasmaa-Minn 1981: 32, Kytömäki 1989). Nevertheless, it may be complicated to assess how established a CSD is in actual cases.

The crucial question in connection with online data is how to treat Internet language. Are we dealing with interaction, speech or a collection of texts? Web genres are not necessarily established in the same way as traditionally published ones; however, as Crystal (2001: 6-7) emphasizes, the linguistic essence of Internet situations displays basically the same kind of systematicity and predictability that is characteristic of the notion of language variety, being governed by situational factors like speech and writing, regional and class dialects, occupational genres and creativity, besides the variety of other styles of expression. Crystal (2001: 24) also points out that the essence of Internet language lies in its relationship both to spoken and written language and in the nature of the medium itself (like the limits set by the characters on the keyboard and the size and configuration of the screen). The constant change of content is a characterizing feature of Internet material, making it complex to handle and to restrict unlimited and dynamic material. However, this feature reflects the changeable nature of language in a straightforward way, compared to the fixed corpora. Approaching the Internet language resources as a dynamic language corpus, it enables us to detect the latest developments as well as test the limits of the language. Internet material can be regarded as a direct indicator of changes in language, providing for a detection of the initiators of potential changes and the connections between analogous cases. For the study of productive phenomena like CSDs, Internet material provides a simple way to confirm if it is generally possible to produce a derivative of a verb or if a CSD is undergoing lexicalization processes. This brings us closer to the concept of language instinct as a property of an individual and as a social collective phenomenon.

Restriction and processing of online data are obviously ineluctable because of the extensive nature of the material. In this study, a flexible approach has been necessary in the compilation of such material. This is due to the heterogeneous nature of CSDs: their distribution is not fixed to certain genres or text types; some of them are, for instance, in frequent use within discussion groups, whereas others are found in highly formal legal-text types. Therefore, the data source could not be restricted according to text linguistic criteria only at this stage of analysis; the qualitative selective approach has been more fruitful in achieving an overview of the CSDs. I have compiled two data collections from the Internet: one based on the discussion forums of the Google Groups Finnish Usenet hierarchy *sfnet* groups and another based on Google web materials. The former represents a uniform text type on the Internet; it is a characteristic online genre characterized by colloquialism, written communication akin to informal speech. However, the language of a

written medium is more controlled than speech, giving the writer time to reflect on the form of the message. The texts of discussion groups are typically an interactive chain of messages written on a given topic; the topic is indicated by the discussion group name. This type of language use can be classified as ‘asynchronous computer-mediated communication’ (see Hoffman 2007 and Petrova 2010), because the communication does not happen simultaneously as, for instance, in chat groups.

The Google web corpus of the occurrences of CSDs is compiled by picking relevant cases from hits. Some tokens are found by serendipity in connection with determined results. With some verbs, I have tested if verb X is in use and in which registers or genres (such as creatively used language or formal texts). The data is fixed in that the time of the search as well as the website or discussion topic it is taken from are frozen. In this way, the spatio-temporal properties of material are determined. The database made of these verbs is of a selective nature: on the one hand, not all of the results are usable because of their deficiency (there are clear indications of lapses or the page has disappeared); on the other hand, if it has been possible to make generalizations on how a verb is used, I have not collected all of its occurrences.

The advantage of Internet data for my study is that it reveals the distribution of CSDs in different spheres of life. It is possible to approach the verbs from different angles, like the text types and genres they occur in, or the communicational aspects of these verbs in a dialogue. The spreading of linguistic properties in the electronic medium can be detected via relatively simple methods. By collecting data from the Internet, I have noticed that the occurrence of some derivatives tends to be centred upon certain text types. Some of them occur e.g. in highly formal texts concerning, for instance, legal matters. Consider examples (4a-b) with the derivatives *avauttaa* ‘make s.o. open’, *etsityttää* ‘make s.o. search’ and *hyväksyttää* ‘make s.o. approve’:

- (4a) *avauttaa* [open-caus] ‘make s.o. open’  
*etsityttää* [search-cause] ‘make s.o. search’

*Ulosottomiehellä on oikeus avauttaa lukkoja ja ovia sekä etsityttää huoneita ja säilytys-paikkoja, jos täytäntöönpanossa sitä tarvitaan.*  
 ‘The distrainer has the right to **make** [s.o.] **open** the locks and the doors, and **make** [s.o.] **search** the rooms and the depositories, if it is needed.’  
 (<http://www.finlex.fi/linkit/sd/20030528>, searched 22.3.2006)

- (4b) *hyväksyttää* [approve-caus] ‘make s.o. approve’

*Mahdolliset muutokset projektisuunnitelmaan tai kustannusarvioon tulee hyväksyttää Tekesillä.*

‘The potential changes in the project plan or cost estimate must **be** [made] **approved** by Tekes.’  
 (<http://www.tekes.fi/rahoitus/yritys/yhteishankkeet.html>, 3.3.2006)

Making a rough division between formal and informal text types, it is clear that some verbs can occur in both e.g. the verb *etsityttää* ‘make s.o. search’ is used in example (5) in a spontaneous narration. Note that another CSD, *ajatuttaa* ‘make s.o. drive,’ is used in this example:

- (5) *ajatuttaa* [drive-caus-caus] ‘make s.o. drive’  
*etsityttää* [search-caus-caus] ‘make s.o. search’

*Noonisiin. Ajatutin kaveria tunnin verran ympäriinsä kun etsitytin sillä tossa muutamana kilsan päässä olevaa McDonaldsia. Löytyi se sitten lopultakin. Ja hyvältäähän se hampurilainen maistuikin.*

‘Well... **Had** the guy **drive** around for about an hour while he looked for [I **let** him **search** for] the McDonalds a few kilometres away. Finally he found it. And the hamburger tasted great.’

(<http://www.brainalmeltdown.net/cybbis/blog/index.php?blogid=2&archive=2002-08>, 22.3.2006)

On the other hand, the topic that unites the experts or devotees of a branch also influences the lexical choices and the differentiation of semantics. The verb *kyykkyttää* ‘make s.o. squat’ is used in the meaning ‘spatial configuration when sitting on a certain type of motorcycle’ only among motorcycle enthusiasts (see example (3e) above). Hence it is possible to detect potential hotbeds and networks behind changes in Internet material. It can be argued that the communicative code system used online reflects the nature of language; therefore, the Internet, in which it is possible to make simple searches, can be approached as a source of linguistic data.

The questions that are relevant for my study include the following: how do CSDs function in speech-like spontaneous language? How do word and construction meanings form within a group of people with shared interests? How do new words and meanings arise? The productivity of causative derivation is unfolding in online language. Consider an example including three CSDs – a compound CSD, a general CSD and a phrasal CSD:

- (6) *kyykkyhypyttää* [squat.jump-caus] ‘make s.o. do squats’  
*punnerruttaa* [press-caus] ‘make s.o. do push-ups’  
*teettää vatsalihasliikkeitä* [do-caus situp-pl-part] ‘make s.o. do sit-ups’

*Kari Pappa Johansson kyykkyhypytti, punnerrutti, teetti vatsalihasliikkeitä. Uudelleen ja uudelleen.*

‘Kari Pappa Johansson **made** (us) **do squats, push-ups and sit-ups**.  
Again and again.’  
(<http://www.pikadon.fi/index.php?id=48>, 22.4.2009)

As a resource for linguistic research, Internet data is beneficial for vetting the prevalence of linguistic phenomena. The examples are often there in context, which enables us to check whether the verb in question is being used as a CSD and also to rule out possible cases of lapses or other irrelevant cases. The form of the searched phenomenon must be specified, but novel expressions and words may be detected in connection with the results. I consider it useful for the present purposes to use different data sources – both the data collected from the Language Bank and from Internet material. I thus regard the online material as an (unstructured) text corpus that serves the purpose of finding CSDs in the contexts in which they are used. As discussed above, the reasons for this solution are the heterogeneity of the research subject in terms of their stylistic value and the importance of examining the use of CSDs in different contexts. In connection to CSDs, the Internet data enables us to take into account the interpretation patterns and pragmatic links between the social interaction and the situation expressed by the proposition (the implicative aspects of CSDs are discussed in particular in section 5.2.6). By varying the data sources, the CSDs belonging to both formal and colloquial language can be studied. However, the limits of this study do not enable an in-depth investigation of the textual aspects of these verbs. The preliminary observations of the behaviour of CSDs in different (online) genres is discussed in section 5.4.2; closer textual analysis of CSDs is left for future research. The notion of context in this study stands for sentential context (which is examined in connection with syntactic-semantic linking regularities), situational context (supporting semantic analysis) and the implicational context (linked to perspective and social interaction).

### 2.3.2 Verbs selected for examination

The actual verb selection is designed to correspond to the purposes of the analysis: the examination of the syntactic, semantic and pragmatic properties of different types of CSDs. Thus, the CSDs selected for syntactic analysis vary by transitivity value and argument structure (the syntactic analysis in chapter 3 does not involve corpus material). The relevant semantic properties of the root verbs are the activity of the main arguments and causativity. A special group in my study are the verbs encoding motion caused by one’s own force; other verbs represent different kinds of activity (concrete or abstract activity directed at another participant or at the actor themselves). Additionally, I have included CSDs derived from stative roots. An additional aim in collecting data on CSDs has been to observe them in context. As

mentioned in the previous section, CSDs are not necessarily found in dictionaries. Therefore, I have sought derivatives by testing them with different root verbs. One important condition of CSDs included in the material is simply that they can be found and with a sufficient degree of occurrence – even if theoretically it is assumed that every root verb is able to produce a causative derivative, in practice they do not automatically exist in the corpora (for instance, only one occurrence of *varastoittaa* ‘make s.o. store’, derived from *varastoida* ‘to store’, was found on Google on 15 September 2010).

In what follows, I present the verbs discussed in this study according to the data source with references to the purpose of the analysis the verbs undergo. The data I have collected from text corpora can basically be divided into three groups according to source<sup>18</sup>. Firstly, from the Language Bank corpus I have collected occurrences of seven verbs: the caused theme motion verb *haetuttaa* ‘make s.o. fetch’ and six motion verbs (*liikuttaa* ‘make s.o. move’ referring to an unspecified motion):

*haetuttaa* [fetch-caus] ‘make s.o. fetch’  
*juoksuttaa* [run-caus] ‘make s.o. run’  
*hyppyttää* [jump-caus] ‘make s.o. jump’  
*kyykyttää* [squat-caus] ‘make s.o. squat’  
*tanssittaa* [dance-caus] ‘make s.o. dance’  
*pyörittää* [spin-caus] ‘make s.o. spin’  
*liikuttaa* [move-caus] ‘make s.o. move’

The second source comprises data from Google Groups discussion forums. I have collected samples with CSDs from the following topics: politics, society, law, religion, national defense, conscientious objectors, economy, language, health, inhabitation, building, music, jokes, children, human relationships, sex, vegetarians, information technology, games, traffic, motorcycle enthusiasts, car enthusiasts, boat enthusiasts, bike enthusiasts, snow sports enthusiasts, pet enthusiasts, hiking enthusiasts, aviation enthusiasts, astronomy enthusiasts, movie enthusiasts, ice hockey and motor sports. The verbs included in Google Groups data are the following (one particular find being the verb *kyykytellä* ‘make s.o. repeatedly squat’, a combination of the causative morpheme *ttA* and the frequentative morpheme *-ele*; two verbs also exemplify double causative morpheme derivatives – *syötättää* [eat-caus-caus] and *leikityttää* [play-caus-caus]):

<sup>18</sup>A technical remark on the material of this study: the Google examples are fixed in time in respect of the data on which they are collected; in connection with the Google Groups and Language Bank data, I present the appearance time of the examples as fixed in these sources.

*kyykytellä* [squat-caus-freq] ‘make s.o. squat’  
*juoksuttaa* [run-caus] ‘make s.o. run’  
*hyppyyttää* [jump-caus] ‘make s.o. jump’  
*kyykyttää* [squat-caus] ‘make s.o. squat’  
*tanssittaa* [dance-caus] ‘make s.o. dance’  
*ryömittää* [crawl-caus] ‘make s.o. crawl’  
*uittaa* [swim-caus] ‘make s.o. swim’  
*ajattaa* [drive-caus] ‘make s.o. drive’  
*maksattaa* [pay-caus] ‘make s.o. pay’  
*laulattaa* [sing-caus] ‘make s.o. sing’  
*syöttää* [eat-caus] ‘make s.o. eat’  
*syötättää* [eat-caus-caus] ‘make s.o. eat’  
*leikityttää* [play-caus-caus] ‘make s.o. play’  
*kirjoituttaa* [write-caus] ‘make s.o. write’  
*pesettää* [wash-caus] ‘make s.o. wash’  
*silityttää* [iron-caus] ‘make s.o. iron’  
*hyväksyttää* [accept-caus] ‘make s.o. accept’  
*tapattaa* [kill-caus] ‘make s.o. have s.o. killed’

The third collection of authentic examples of which I make use in my study consists of data from the Internet, comprising 118 verbs. Not all of these verbs are directly discussed in this study; their function has been mainly to be part of the map-making process of CSDs. Since the goal was to detect various types of CSDs, the result is a miscellaneous set of verbs, sought and selected by different criteria: structural (transitive and intransitive root verbs, verbal and nominal roots and one or two causative morphemes), semantic (causative and non-causative roots, different types of activity and active or stative root verbs) and stylistic variation (slang, periodical texts and legal texts). In chapter 4, the agent properties and temporal relationships of the CSDs are discussed. The verbs selected from the online corpus of CSDs for these purposes are the following eight:

*otattaa* [take-caus] ‘make s.o. take’  
*keitättää* [cook-caus] ‘make s.o. cook’  
*paistattaa* [bake-caus] ‘make s.o. bake’  
*puhalluttaa* [blow-caus] ‘breathalyse’  
*notkistuttaa* [become supple-caus] ‘make s.o. become flexible’  
*haetuttaa* [fetch-caus] ‘make s.o. fetch’  
*pyöräilyttää* [cycle-caus] ‘make s.o. cycle’  
*itkettää* [cry-caus] ‘make s.o. cry’

The verbs discussed in chapter 5 illustrate the idiomatic functions of CSDs. The constructional analysis is based on variation and observations of authentic expressions. Some of the CSD constructions appear to have a

special role in social interaction; therefore, it is important to study them in a broader context. The motion verbs *juoksuttaa* ‘make s.o. run’, *hyppyttää* ‘make s.o. jump’ and the denominal CSD *kyykyyttää* ‘make s.o. squat’ being found in all three corpus sources can be used in the Power Misuse Construction (PMC); these verbs have a negative power relation between the main arguments as a common feature. The social relationship lexicalized in this construction stems from the salient semantic feature of CSDs, the special relation between the main arguments where the subject argument induces the second (animate) argument to perform an action. Other PMC verbs discussed in chapter 5 comprise derivatives of different motion verbs as well as some denominal causatives (note that all 16 verbs include a meaning component of ‘boss s.o. around’):

*kävelyttää* [walk-caus] ‘make s.o. walk’  
*tanssittaa* [dance-caus] ‘make s.o. dance’  
*pyörittää* [spin-caus] ‘make s.o. spin’  
*ryömyyttää* [crawl-caus-caus] ‘make s.o. crawl’  
*kontatuttaa* [crawl-caus] ‘make s.o. crawl on all fours’  
*kynittää* [pluck-caus] ‘exploit s.o.; beat’  
*poistuttaa* [remove-caus] ‘make s.o. exit; move s.o. off/back’  
*pompottaa* [bounce-caus] ‘walk over’  
*pallottaa* [ball-caus] ‘walk over’  
*penkittää* [bench-caus] ‘make a player sit on the bench’  
*nakittaa* [frank-caus] ‘give s.o. unpleasant tasks’  
*kepittää* [stick-caus] ‘beat s.o.’  
*rökittää*<sup>19</sup> ‘defeat’ (<*rökäle* or *rökki*)  
*nokittaa*<sup>20</sup> [peck-caus] ‘beat s.o.’  
*kampittaa* [trip-caus] ‘trip s.o. up’  
*höykyttää*<sup>21</sup> ‘hammer s.o.’

The other verbs from online data discussed in connection with constructional CSD patterns are:

*syöttää* [eat-caus] ‘make s.o. eat, feed s.o.’  
*syötättää* [eat-caus-caus] ‘make s.o. eat’

<sup>19</sup>The verb *rökittää* is obviously related to the adverbial expression  *antaa rökkiin* ‘give s.o. a pasting, thrash’ (NS). The etymology of the noun *rökki* is, according to the Finnish etymological dictionary (SKE), the Norwegian word *rygg* ‘back’ or *piiskattava paikka* ‘the place to whip’.

<sup>20</sup>The verb *nokittaa* has, according to the NS, three meanings: 1. knock with a pointed object; 2. taunt, needle; 3. raise the stakes (a term in poker).

<sup>21</sup>The verb *höykyttää* has no clear root word but is thought to be associated with the expression  *antaa höykynköykkyä* ‘give s.o. a licking’. This verb is explained in the NS as a military slang word meaning ‘arrange an extra drill or exercise’. The translation of *höykyttää* in KS is ‘hammer’.

*syötäytyttää* [eat-caus-caus-caus] ‘make s.o. eat’  
*juottaa* [drink-caus] ‘make s.o. drink’  
*juotattaa* [drink-caus-caus] ‘make s.o. drink’  
*juotatuttaa* [drink-caus-caus-caus] ‘make s.o. drink’  
*kompastuttaa* [stumble-caus] ‘make s.o. stumble’  
*purettaa* [bite-caus] ‘make s.o. bite’  
*äänestyttää* [vote-caus] ‘make s.o. vote’  
*teettää* [do-caus] ‘make s.o. do’  
*haetuttaa* [fetch-caus] ‘make s.o. fetch, bring’  
*etsityttää* [seek-caus-caus] ‘make s.o. find, seek, look’  
*vapisuttaa* [shudder-caus] ‘make s.o. shudder’  
*puhalluttaa* [blow-caus] ‘blow/puff out’  
*potkituttaa* [kick-caus-caus] ‘make s.o. kick; feel like kicking’  
*punnerruttaa* [press-caus] ‘make s.o. do push-ups’  
*ajatuttaa* [>*ajatella*: think-caus] ‘make s.o. think’  
*ajaututtaa* [>*ajaa*: drive-caus-caus] ‘make s.o. drive’  
*ajeluttaa* [>*ajaa*: drive-fre-caus] ‘make s.o. drive’  
*hyppyyttää* [jump-caus] ‘make s.o. jump’  
*tanssittaa* [dance-caus] ‘make s.o. dance’  
*leikityttää* [play-caus-caus] ‘make s.o. play’  
*lenkityttää* [jog-cause-cause] ‘make s.o. jog’  
*tunnistuttaa* [recognize-caus] ‘make s.o. recognize’  
*voimisteluttaa* (< *voimistella* ‘do gymnastics’) ‘make s.o. do gymnastics’  
*muistututtaa* (< *muistuttaa* ‘remain’)  
*katsotuttaa* [watch-caus-caus] ‘make s.o. watch’  
*kuunteluttaa* [listen-caus] ‘make s.o. listen’  
*saatattaa* (<*saattaa* ‘may’)  
*otattaa* [take-caus] ‘make s.o. take’  
*otatuttaa* [take-caus-caus] ‘make s.o. take’  
*otatella* [take-caus-fre] ‘make s.o. take (repeatedly)’  
*jätättää* [leave-caus] ‘make s.o. leave’  
*päättä raavituttaa* [head-part scratch-caus-caus] ‘make s.o. scratch their head’  
*kokeiluttaa* [try-caus] ‘make s.o. try’  
*avauttaa* [open-caus] ‘make s.o. open’  
*etsityttää* [seek-caus-caus] ‘make s.o. find, seek, look’  
*pesetyttää* [wash-cause-caus] ‘make s.o. wash’  
*kaivattaa* [dig-cause] ‘make s.o. dig’  
*toteututtaa* [execute-caus] ‘make s.o. execute’  
*vangituttaa* [arrest-caus] ‘make s.o. arrest’  
*kuulusteluttaa* [question-caus] ‘make s.o. question’  
*tuomituttaa* [sentence-cause] ‘make s.o. sentence’  
*itkettää* [cry-caus] ‘make s.o. cry’



*röyhtäyttää* [burp-caus] ‘make s.o. burp; burp’  
*konttauttaa* [crawl-caus] ‘make s.o. crawl’  
*kontatuttaa* [crawl-caus-caus] ‘make s.o. crawl’  
*maksattaa* [pay-caus] ‘make s.o. pay’  
*kampittaa* [trip-caus] ‘trip up’  
*kynittää* [pluck-caus] ‘exploit; beat’  
*hassuttaa* [funny-caus] ‘fool around; feint’  
*tylyttää* [harch-caus] ‘say harshly’  
*otteluttaa* [compete-caus] ‘make s.o. compete (in a match)’  
*makuuttaa* [lie-caus] ‘have oneself lain in bed’  
*nostatuttaa* [lift-caus-caus] ‘make s.o. lift’  
*vaipotuttaa* [diaper-caus-caus] ‘have s.o. put s.o. in a diaper’  
*pyyhittää* [dust-caus] ‘make s.o. dust’  
*teettää* [do-caus] ‘make s.o. do sth’

Some *ttA*-causatives of my Google material show an ability to occur in the Finnish ‘emotive causative frame’ (see section 5.3.1 for a more detailed discussion of this phenomenon). These are verbs derived with a double or even triple causative suffix (note that the first four of these also occur as general CSDs):

*syötäytyttää* [eat-caus-caus-caus] ‘make s.o. feel like eating’  
*juotatuttaa* [drink-caus-caus-caus] ‘make s.o. feel like drinking’  
*leikityttää* [play-caus-caus] ‘make s.o. feel like playing’  
*katsotuttaa* [watch-caus-caus] ‘make s.o. feel like watching’  
*opituttaa* [learn-caus-caus] ‘make s.o. feel like learning’  
*kyykytyttää* [squat-caus-caus] ‘feel like going into a squat; feel like oppressing s.o.’

As examples of creative derivation, I present the following compound CSDs in chapter 5:

*kauneusleikkauttaa* [cosmetic.surgery-caus] ‘make s.o. initiate cosmetic surgery on themselves’  
*salamurhauttaa* [secret.murder-caus] ‘make s.o. assassinate s.o.’  
*pakkosyötäytyttää* [compulsion.eat-caus-caus-caus] ‘make s.o. compulsively eat’  
*kyykyhyppyttää* [squat.jump-caus] ‘make s.o. do squats’

I also discuss the following six *ttA*-derivatives used in slang in chapter 5.4.1:

*guruttaa* [guru-caus] ‘expertise, fix something’  
*warettaa* [Eng. ware-caus] ‘ware’  
*imuttaa* [suck-caus] ‘download’

*hypettää* [Eng. hype-caus] ‘hype’  
*googlettaa* [google-caus] ‘do Google searches’  
*mukettaa* [Eng. nuke-cause] ‘kill with a nuclear bomb, radiate’

In connection with the study of the verb *kyykkyttää* ‘make s.o. squat’ in section 5.2.4.2, I analyze a closely related idiom, *köyhät kyykkyy*, meaning that poor people should understand their position/ behave humbly etc. For this reason I have collected data on this idiom from Google Groups; in the Language Bank corpus I found only six occurrences of the idiom.

There is also a fourth data source which is used in this study – in addition to the corpus data, it was necessary to test the intuition of language users. In order to obtain support for the construal of the argument structure of the CSDs analyzed, it was necessary to perform a language instinct test on the sentential alterations discussed in connection with the syntax-semantic interface analysis of the CSDs in chapter 3. This test is explained in detail in section 3.1.4. The investigation of the effect of syntactic properties of the root verb on the derivative structure involves questions as to whether the adessive adjunct is only possible as part of the argument structure of CSDs derived from transitive root verbs and if and under what conditions the same CSD allows us to express the performer of the action both in the adessive and object cases. Firstly, I have made a selection of verbs for a syntactic test on the basis of their syntactic properties from transitive root verbs to intransitive root verb. The verbs selected for the syntactic test are:

*ompeluttaa* [sew-caus] ‘make s.o. sew’  
*teettää* [do-caus] ‘make s.o. do’  
*syötättää* [eat-caus-caus] ‘make s.o. eat’  
*laulattaa* [sing-caus] ‘make s.o. sing’  
*juoksuttaa* [run-caus] ‘make s.o. run’  
*jonottaa* [queue-caus] ‘make s.o. queue’

The root verbs of the causatives selected for the syntactic analysis can be seen as a continuum: *ommella* ‘to sew’ is a clearly transitive production verb (Fi. *valmistusverbi*), *tehdä* ‘to do’ an abstract action verb (Fi. *teko-verbi*); the implicit object verbs *syödä* ‘to eat’ and *laulaa* ‘to sing’ belong to the middle ground between transitive and intransitive verbs; *juosta* ‘to run’ is a dynamic intransitive verb; and *jonottaa* ‘to queue’ a static intransitive verb (the basis for verb selection is the transitivity-based classification of Pajunen 2001: 283-288). The last verb represents a stative verb group that has a temporal and not a constant reading. It resembles predicates like ‘sit’, ‘stand’ and ‘lie’ that denote the particular spatial orientation of an object within its location, as Dowty (1991:560) defines it. The syntactic analysis of these verbs is based on constructed sentences. The language instinct test involves one verb from each group: *ompeluttaa* ‘make s.o. sew’, *syötättää* ‘make s.o. eat’ and

*jonotuttaa* ‘make s.o. queue’. By varying the arguments in the sentences, the limits of well-formed CSD sentence are tested and the differences between the selected verbs studied. The same verbs also appear in other parts of my thesis, as my particular interest lies in the linking system between syntax and semantics, which will be studied through the conceptual structure. The CS analysis of these verbs is given in section 3.3.

In addition, chapter 3 involves a closer analysis of the verb *leikittää* [play-caus] ‘make s.o. play’, functioning as an example of flexible syntactic and semantic interfaces (which is the topic of section 3.5). Using the example of *leikittää*, I discuss the argument linking between syntactic and semantic arguments as well as the well-formed placements of the root verb arguments in a derivative sentence. Since *leikittää* represents the middle ground in the transitivity continuum (see the discussion about transitivity in 2.5), I aim to investigate its adaptable argument structure. Online data serves as support for the argument structure variation analysis of this verb.

Hence, the verbs selected for actual analysis serve different purposes. For introspective analysis I have chosen verbs according to their argument structure and other relevant features for the study (type of activity, number of causative suffixes, causative vs. non-causative verbs and control feature). In the introspective analyses, the following verbs are discussed:

*teetättää* [do-caus-caus] ‘make s.o. do’  
*kaivauttaa* [dig-caus] ‘make s.o. dig’  
*otatuttaa* [take-caus-caus] ‘make s.o. take’  
*tuotatuttaa* [bring-caus-caus-caus] ‘make s.o. bring’  
*kävelyttää* [walk-caus] ‘make s.o. walk’  
*veistättää* [carve-caus] ‘make s.o. carve’  
*heitättää* [throw-caus] ‘make s.o. throw’  
*ajattaa* [drive-caus] ‘make s.o. drive’  
*juokuttaa* [run-caus] ‘make s.o. run’  
*tansittaa* [dance-caus] ‘make s.o. dance’  
*pyöräilyttää* [cycle-caus] ‘make s.o. cycle’  
*pyöräilytyttää* [cycle-caus-caus] ‘make s.o. cycle’  
*otteluttaa* [compete-caus] ‘make a player compete or fight (in a match)’  
*tapattaa*<sup>22</sup> [kill-caus] ‘make s.o. kill s.o.’  
*pesettää* [wash-caus] ‘make s.o. wash’  
*liukastua* [slippery-inch] ‘slip’,  
*hämmästyä* [?] ‘be astonished’  
*pelottaa* [be frightened-caus] ‘frighten; be frightened by sth’

<sup>22</sup> This verb is also supported by an example taken from NS.

Finally, we can ask why CSDs are so frequent in Internet texts. One explanation is that the traditional corpora are restricted and do not reflect all language use, such as creative use. Another reason may be that CSDs are expressive and compact; they convey attitudes that can be added to a proposition. In addition, I would argue that CSDs represent an idiomatic linguistic vehicle of expression of Finnish. The verbs I have collected from the Internet do not give a comprehensive account of CSDs in use, but for the present purposes it is not necessary to list all possible CSDs. I will focus on the properties of the selected verbs, which were chosen for different purposes.

## 2.4 Prototypes and the lexical analysis

### 2.4.1 Classical and prototype-based categorization

As discussed briefly in section 1.2, classifying *ttA*-causatives as a homogenous lexical class based on morphosyntactic criteria is problematic. How are CSDs related to each other and how do they capture both the shared and variable properties of the derivatives? What is the nature of causative derivatives as a linguistic phenomenon? In this section, I argue for the use of the notion of ‘prototype’ in the analysis of CSDs from the point of view of their lexical organization.

Compared to the primary theoretical basis of this study i.e. conceptual semantics, prototype represents a fundamentally different type of notion than those conceptual semantics operates with. Traditionally, the nature of linguistic categories is based on two kinds of traditions: classical (Aristotelian) categorization and prototype-based categorization. By the classical categorization definition, the categories have clear-cut boundaries in the sense that entities are either members of a category or not. Classical categories are defined in terms of the conjunction of necessary and sufficient features. Another characteristic aspect of classical categorization is that all of the members of a category have equal status (Taylor 1989). The grammatical categories of conceptual semantics can thus be said to represent the classical approach to categorization; in the organization of grammar the representations are considered discrete categories and the representations operate with properties that are binary or privative in nature – a phenomenon may switch between one position and another (+/-) or may possess or lack a feature.

In contrast to classical categorization, the boundaries of prototype-based categories are not expressly definite. Another sign of the prototype-based category is that the members of a category may have different status; as Rosch’s (1978) research on the internal structure of categories indicates, some of the members may be more typical, ‘better’ examples of a category than others. Rosch’s well-known example on prototypicality is the natural

category of 'bird' – there are differences in how exactly different kinds of birds correspond to the concept of bird; for instance the swallow is 'birdier' than the penguin. Here, it is important to distinguish between 'degree of membership' and 'degree of representativity'; as Lakoff (1987) points out, clearly bound concepts (like 'bird') may have prototypicality effects within the concept. It has been shown in psycholexical empirical investigations especially that the degree of membership in a category is a psychologically real notion (Rosch 1978 and Labov 1973). Moreover, Rosch (1978) suggests that prototype effects are involved in different kinds of cognitive activity. Hence, with prototype-based categorization we can take into account the blurred nature of category boundaries when based on graded membership in a category or variations in representativity.

According to Taylor (1989: 54-59), there are basically two kinds of prototype categorizations within the prototype theory. Firstly, a prototype stands for the central member or cluster of central members of a category (a typical instance of a category). The second prototype definition is a more abstract characterization, embracing a schematic representation of the conceptual core of a category, which is not understood as a matter of gradation. In this case, the prototype is not an exemplar of the category but instantiates the prototype.

Would the linguistic categorization have a use for both types of taxonomy, classical and prototypical? If we consider, for example, word classes, these categories exclude each other by definition. In the event that a word's shape appears to adopt the properties of both substantive and verb, in a larger unit it functions either as a verbal or nominal unit. Hence, not all lexical features reduce to one another but are separate primitives. On the other hand, the combinations of features cannot be fixed, given the richness and creativeness of language; the essential aspect of language is how the primitives come together.

The starting point of this study is the hypothesis that the combinatorial variation between lexical entries gives us grounds for relationships within lexically related groups. I argue that it is methodologically useful to operate with defined categories in order to describe the prototype patterns. Hence the grammatical categories in my study are seen as classical categories. Alternatively, I assume that the description of lexical organization, especially morpholexical complexity, benefits from categorization that takes into account the variations within the lexical category. As Geeraerts (1989: 589) points out, the prototype approach provides a model for accounting for the phenomena related to lexical flexibility such as polysemy of lexical items, gradedness and fuzziness of category boundaries, clustering of senses etc. However, if we aim for an explicit definition of the grades in a continuum or the conceptual core of a category, we need to break the phenomenon down to smaller constituent parts. Therefore, in order to combine classical and prototype-based categorization, a solution could be to consider primitive

categories as thematic roles and syntactic/semantic functions as ‘classical’ but the larger combinations like lexical groupings and constructional patterns in compliance with the prototypical principles. Theories based on the prototype idea have been criticized for their neglect of any sort of decompositional analysis (see Geeraerts 1989). The advantage of uniting the two approaches is that we do not have to abandon compositional analysis: the variation can be described by means of the components.

In my study, I apply the notion of prototypes in the lexical analysis of CSDs. I argue that the concept of ‘prototype’ is a useful tool in approaching these derivatives as independent lexical units and at the same time the features that are common to these lexemes. In my analysis of CSDs, the prototype notion stands for the typical conceptual and morphosyntactic structure of the derivatives. However, as it is the conceptual core in the sense that we can compare the structures of single verbs against it, we can say that it represents the abstract type of prototype, the abstract pattern – not a single verb that represents the verb group. I use prototype templates as a point of comparison the verbs and constructions can be related to. I assume that the schematic prototypes represent a more general phenomenon in language than word formation processes; the patterns describe the organization of lexicon, and how the single lexemes are attached in clusters. The prototype concept also provides a reference value in reflecting on the material from language use. It is useful because we are not forced to specify the ‘core meaning’ of a word or a construction in cases where it is not sensible to do so.

A significant question is: in what sense is something prototypical? This concept itself embodies an indication of comparison. In this study, the prototype is seen as a combination of different features, serving as a template. By capturing the primitive components of a phenomenon, we can define the conceptual core of a category. Then different cases can be compared to the abstract template, and we can detect the typical and non-typical combinations of the primitives. For the verb analysis in this study, the identification of prototypes as default structures plays a central role in the discussion of constructions; the emphasis is on the question: in what respect are the combinations of primitives reminiscent of the prototype structure, and where do we find variations?

As a possible approach to the processes behind word formation, the latest Finnish reference grammar (ISK §147-148) introduces the notion of ‘mould’ (*muotti*) as an explanation for the regularities and structural-morphological resemblances behind word formation. Mould, in a sense, appears to be a description of a prototype embodying a productive rule:

Tällainen johdostyyppin edustama sanahahmo toimii samalla muottina, jonka mukainen sana voi olla muutakin kuin läpinäkyvä, kantasanallinen johdos. Muottiin kuuluu sanavartalon loppu (-*lA*, -*ttA*), joka monessa tapauksessa hahmottuu suffiksiksi, sekä tila vartaloainekselle, jona voi olla leksikaalinen

vartalo tai muu fonologinen aines, esim. deskriptiivinen äänijono. Muotti tarjoaa analogiaan perustuvan sananmuodostus-mallin, jonka perusteella voi syntyä uusia johdoksia sekä muitakin samanahhmoisia sanoja. Johtaminen on muotteihin perustuvan sananmuodostuksen säännöllisin laji. (ISK §148)

‘A word shape that a derivative type represents functions at the same time as a ‘mould’, and a word that matches this mould can even be something other than a transparent derivative with a base word. The mould comprises the ending of the word stem (-*lA*, -*ttA*-), in many cases taking the shape of a suffix, as well as a slot for the stem material, which can be a lexical stem or another phonological substance, for instance a chain of a descriptive speech sound. The mould provides an analogy-based model for word formation which can be the basis for the emergence of new derivatives as well as other words with the same shape. Derivation is the most regular word formation type based on the moulds’.

The mould is thus understood as a notion capturing the processes in word formation that are based on analogy, considering the phonological form of a word. This concept is also applied to constructions where a verb requires a complement in addition to its core arguments, called a ‘valence mould’ (Fi. *täydennysmuotti*) (see ISK §449), or even to a clause type<sup>23</sup> (see ISK §893), becoming a somewhat diffuse notion. It is not specified when the word derivation is seen as a mould-based relation and when it is a productive transformative process; a mould is not used for instance in the description of curative causatives. The mould notion could serve the same purpose I strive for in analysing CSDs, but as it is not more explicitly defined, I simply use the notion of prototype for the general patterns emerging in my analysis. This solution is also motivated by the importance of keeping the prototype notion apart from the concept of construction.

### 2.4.2 Defining CSD prototypes

A theoretical goal of my study is to unify the notion of prototype with conceptual semantics formalism. Based on the formal description of the target linguistic phenomenon, the analysis is expected to clarify the kind of entities that CSDs stand for, and furthermore the kind of relation that exists between the entities that CSDs represent. In this section I provide a preliminary description of CSD prototype structures, which are examined further in connection with the argument structure analysis as well as the

---

<sup>23</sup> In § 893, the Finnish existential clause is seen as a mould, which explains the discerning of non-existence verbs as existential in cases where the clause begins with the locative and the word order is VS, as is characteristic of this clause type. The § 464 talks about transitive moulds, which are equated to resultative moulds; the notion of ‘mould’ may thus be seen as a concept similar to ‘construction’.

closer semantic analysis in chapters 3-4. The constructionist point of view on CSDs in chapter 5 also evokes discussions of the status of prototype structures.

Depending on the LCS of the root verb, the CSDs display crucial differences in the way they behave both syntactically and semantically. These differences are observable in the following examples:

- (1) *Tom korjauttaa Matilla pyörän*  
 Tom repair-caus-pres-3sg Matti-ade bicycle-acc  
 ‘Tom makes Matti repair the bike’

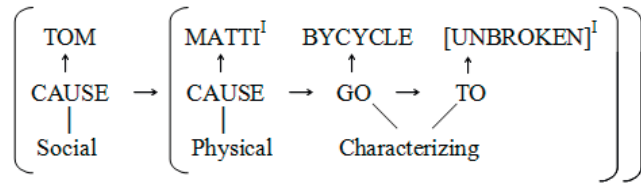

In example (1), there are two causations in the thematic tier of this conceptual structure, assigned by the function ‘cause’. The first cause-function selects the subject argument ‘Tom’ as the causer. The superscript index I of the second causer ‘Matti’ indicates implicitness i.e. an argument marked with index I is not linked to the syntactic representation by the LCS of the verb. Also, the goal argument (‘unbroken’) is in this case implicit (this is not a common feature of CSDs), indicating the state into which the bicycle is being transformed. The theme argument ‘bicycle’ (assigned by the function ‘go’) is undergoing a transition. The communicative connection between the two causers is described in the social semantic field. The second causation of (1) is described in the physical semantic field, and the transition of the theme is described in the characterizing semantic field. The characterizing semantic field describes, according to Jackendoff (1990: 116-122), the transformation in shape which the theme referent is undergoing, typically appearing as a source or goal.

- (2) *Tom marssittaa Matin kauppaan.*  
 Tom march-caus-pres-3sg Matti-acc shop-ill  
 ‘Tom makes Matti march to the shop’

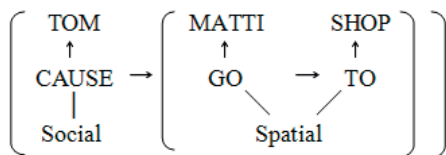



The LCS of sentence (2) includes only one causation; consequently the second (active) animate argument (MATTI) bears the thematic role theme, not the causer. The semantic field of causation is also social here; in the core zones, the semantic field is spatial.

We can conclude so far that there are two different types of CSDs depending on thematic structure: one with two causations, and the second one with only one causation in the LCS. The general conceptual structure of these types can thus be pictured as in (3) and (4), where (3) describes those derivatives that have causative verbs as a root and (4) stands for those with a non-causative root. I do not mark the semantic fields of the LCS of the root verb, because it is not fixed, depending on the LCS of the root verb. The boxes in (3) and (4) separate the structures of the root verbs from the structures of the whole derivatives.

### (3) The double-causative CSD

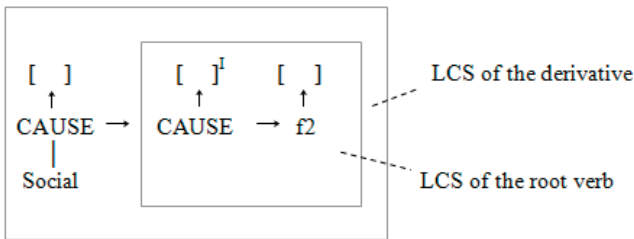

### (4) The single-causative CSD

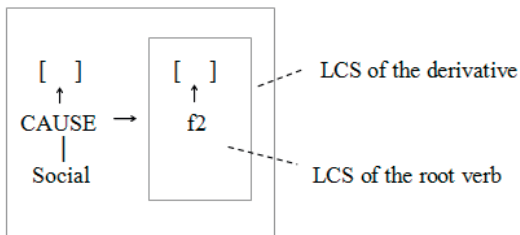

For a more explicit account, I also link the morpholexical level (the SAD and SAR) and the DA level to the prototype structures. This gives us an idea of how the morpholexical arguments are situated in the derivative structure, and also how the syntactic arguments are linked to the thematic arguments. The hypothesis at this point is that the two prototype structures behind the CSDs represent the default cases of regular linking. The prototypes are presented in (5) and (6) respectively. In prototype 1, the argument of the second cause-function is linked to the SAR at the morphological level. In prototype 2, the SAR is linked to the theme argument. Semantically, the

argument linked to the SAR expresses the same relation in both prototypes – it is the performer of the action denoted by the root verb.

(5) Prototype 1 of CSD

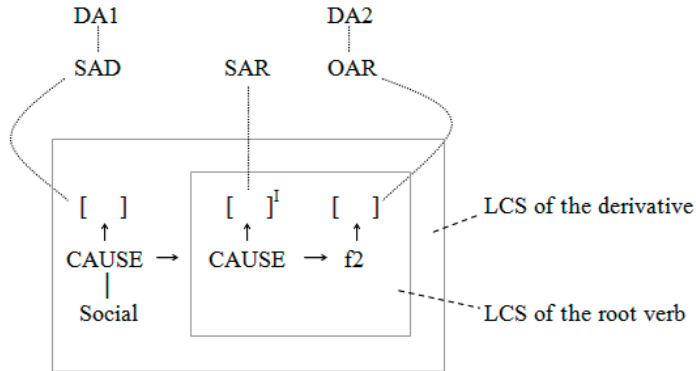

(6) Prototype 2 of CSD

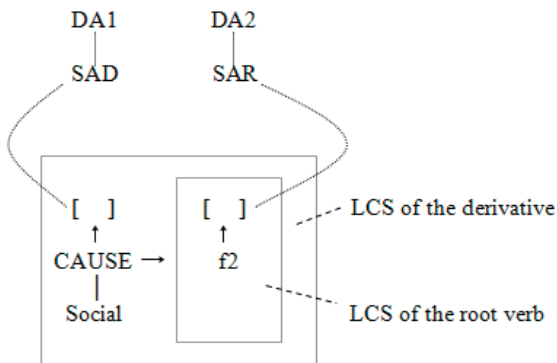

The preliminary proposal of the CSD prototype structures and the linking system configurations raises several questions. Does the double-causative prototype (prototype 1) correspond to the morphosyntactic assumption of curatives (see section 1.2)? How does the causativity of the root verb impact on the LCS of the derivative? Does the linking configuration DA2–OAR in prototype 1 and DA2–SAR in prototype 2 describe a regular correlation? We will return to these questions regarding the prototypes in chapter 3; the prototypes as presented here will be analyzed again in section 3.4 after a thorough argument structure analysis of different types of CSDs. We will see that the prototypes as presented here are only subtypes of more general patterns, and that more precise structures can be specified.

Could the prototype structures presented above be argued to represent constructional patterns? They stand for fixed linking relations, but in contrast to constructions, these prototypes do not connect certain meanings to certain forms but represent properties of the lexicon. Hence the prototypes function rather as templates representing the conflating factors of CSDs. If a verb's LCS matches the structural aspects of the prototype, it can be associated with other verbs of the prototype – the more common features a verb has with the template, the more probable it is that it will behave in the same way as the CSD prototype. Prototypes 1 and 2 are defined according to the result of the derivation process. A consequence of the definition of CSD prototypes is that it does not set particular premises on the root verb of a CSD; it is not required that the root verb be a transitive or causative verb (if the root is not causative, it corresponds to prototype 2). I argue that since both causativity and transitivity are non-permanent properties of verbal lexical items, a classification of derivatives based on these criteria on the root verb does not lead to a satisfactory result. The reasons for abandoning particular criteria on the root verbs in my prototype definitions for CSDs are discussed in more detail in section 2.5.

Is the consequence of defining the properties of the abstract prototype of a derivative group that a prototype template receives default status? In order to identify the effect of the prototype on lexical organization, the actual mappings between different modules and also divergences from the prototype should be carefully defined. In this study, constructions are defined as discrepant in relation to the prototype structures; I assume that the prototypes reflect the productive rules and the variations in linking configurations or the conceptual structure give grounds for construction-building. This assumption is in line with the ideas of Nikanne (2002 & 2005) and Pörn (2004), assuming that there are both regular and irregular cases of linking. What is the function of the *ttA*-morpheme? Does it have an independent and invariant meaning? The discussion about CSD constructions in chapter 5 explicates how the constructional patterns are connected and related to the prototypes. This study concerns the principles behind the grouping of verbs and the role of prototypes and constructions in it, suggesting that constructions determine the verb groupings, and prototypes determine the lexical behaviour.

## **2.5 Causation and transitivity**

The discussion in this section concerns two central concepts traditionally related to causative constructions: causation and transitivity. These notions tend to be definitionally somewhat intertwined in literature; this is also the case of the Finnish curative causatives, as was shown in section 1.2. Both are also regarded as fundamental for human cognition and linguistic universals (see for instance Hopper & Thompson 1980; Tomasello 1999, Shibatani

2002). To begin with, let us outline what the notion of causation is. Firstly, there is an important distinction between causation in language and in the ‘real’ world. Talmy (1976: 47-48) makes a distinction between the term ‘causation’ as used in a semantic analysis of language and the scientific notion of causation in the physical world so that semantics investigates the organization of notions in the mind in connection with their expression in language, whereas an ‘event’ in the physical world relates causally outside of itself and contains causal relations within it (organization of notions vs. organization of phenomena). Thus, a causative proposition does not have a direct correspondence to causation in physical reality but reflects how we conceptualize a causative situation (see also Langacker 1987 and Pinker 1989). Nevertheless, the understanding of causality precedes language, and linguistic structuring depends on the physical, social, psychological and cultural explanation of causal processes (Tomasello 1999).

Causation is generally explained through the notions of ‘activity’ and ‘change’. These are both central in the definition of causation used for instance in ISK (§463), where it is explained as the activity of an active causer directed to another entity, which is followed by a change related to the other entity. Also, Pajunen (2001: 122) emphasizes that the effect of causation appears as a change of state. The notion of causation thus stands in close connection to agentivity, involving the (protoroles or) prototypes of agentivity in the sense of Dowty’s (1991) proposal: there is an active agent and a patient that undergoes a change. To what extent does the notion of ‘change of state’ involve knowledge of the organization of phenomena, as Talmy formulates it (see above)? Consider the sentence ‘I held the apples up’ – something is caused in regard to the apples, but how do we define the change that happens in the patient? Is the change of location considered a change of state?

A causative proposition can also be described more generally via the events embodied in it. Shibatani (1976: 1) explains the causative situation by means of a ‘causing event’ and a ‘caused event’. In their logical structure analysis of predicates and the semantic relations between them and their arguments, Foley and van Valin (1984: 38) regard ‘cause’ not as an abstract predicate but rather a sentential connective that relates the causing event to the caused event. In such analysis, causation is not treated as a relationship between an individual and an event, but as a relationship between two events. There is also an assumption regarding causation that the caused event would not be able to exist without the causing event (see e.g. Shibatani (1976)) or ‘the person’s action’ (Talmy 1976). This leads to an implicative relation between the causing event and the effect (‘John forced Tom to run’ → ‘Tom ran’).

There is no agreement on the question of how to break up the linguistic notion of causation into subcategories. Talmy (1985: 79) distinguishes between nine types of causative vs. non-causative events, assuming that the

range of subtypes a verb incorporates is inconsistent. These types are the following (as we can see, the verb ‘to break’ incorporates seven of the nine causation types):

(1) a. Autonomous event (not causative)

*The vase broke.*

b. Resulting-event causation

*The vase broke from a ball hitting it.*

c. Causing-event causation

*A ball's hitting it broke the vase.*

d. Instrument causation

*A ball broke the vase (by hitting it).*

e. Author causation (i.e. with the result unintended)

*I broke the vase by hitting it with a ball.*

f. Agent causation (i.e. with the result intended)

*I broke the vase by hitting it with a ball.*

g. Undergoer situation (not causative)

*I broke my arm when I fell over. (= My arm broke [on me] when I fell over.)*

h. Self-agentive causation

*I walked to the shop.*

i. Inducive causation (caused agency)

*I sent him to the shop.*

Another subject of discussion is the kind of causation that is the most archetypal. The distinctions are generally based on the properties of the agent and the patient or the type of activity. Croft (1993: 58) has reduced Talmy's causation types to four categories and assumes that the prototypical type of causation is **volitional causation**, where the agent acts volitionally in respect to a physical being ('break the window'). The other causation types in Croft's analysis are **physical causation**, where a physical being operates in respect to another physical being ('the stone broke the window'); **inducive causation**, where the agent influences another being by getting it to perform a new action ('X made Y throw the stone'); and **affective causation**, where a physical entity achieves a change in someone's mental state ('The stone hurt X'). However, not all researchers regard volitional causation as prototypical causation (see for instance Talmy 1976 and Dowty 1991). On the distinction between the different types of events, Pajunen (2001: 121) notes that the process of volitional and inducive causation is more controllable than in the physical; when it comes to a state, the feature of control is usually entirely lacking. She (ibid. 42) also suggests that there are more grounds to regard inducive causation as prototypical causation.

Croft (1993: 59) is among those researchers who apply the notion of the causal chain of events (see for instance Givón 1974 and Talmy's 1976 'serial

causation’) or causal chain. He explicates the notion of volitional causation using the linear causal chain, where a person acts physically on an instrument, which acts physically on an object undergoing a change of state as a result of the action and affecting the mental state of the benefactive participant. He argues that the causally prior end of the causal chain represents the initiator, and assigns the subject in a typologically uniform case in the simple active voice; the endpoint is assigned the object, respectively. The causal chain of Croft is presented in (2):

(2) ‘I broke the coconut open for Janet with a hammer’:

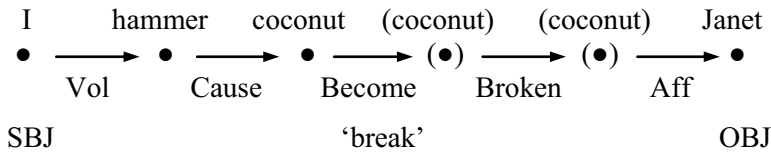

However, the order of the linear causal sequence is not straightforward, since the last segment (the benefactive participant ‘Janet’) has an effect on the whole as well. One could even argue that without Janet the whole sequence of events would not happen, and Janet can be interpreted as the reason (or the inspiration) for this causal chain by instigating Tom to action. Another problematic aspect is the interpretation of benefactive – we cannot declare, on the basis of the proposition in (1), what the reaction of the mental state of the second participant really is, as the linguistic expression does not specify it. The purpose of the action may be meant as a benefit to Janet, but she is not necessarily aware of the action; in a suitable context, she could even be angry that I broke open the coconut. An additional remark on the causal chain in (1) concerns the assumed object marking: presumably, the argument linked to the endpoint of the chain is assigned as the object, but actually, in the case of proposition (1), the endpoint (Janet) does not assign the object but the adjunct. However, this example shows the complexity related to causative constructions.

We can conclude so far that in connection with the research subject of this study, the inductive causation type is central. A CSD event complex typically involves two in some way active human participants, and the causation is characterized by social influencing between the participants. However, this type of causation also involves the notion of volitionality; in Givón’s (1974: 63) words: a state or an event can be accidentally made to come into being, while one can only deliberately make another person perform an action. From the point of view of the interactional relationship between the actors, the semantic feature ‘control’ is also significant. J. Leino (2003: 136-137) describes the control feature of the permissive construction so that the subject

referent of the verb *antaa*<sup>24</sup> ‘to let’ has the explicit ‘supreme control’ over the situation described in the infinitive construction (*antaa kaverin mennä* ‘let the buddy go’). The special characteristic of the permissive construction is that the causer has the ability to prevent the situation. How are control relations manifested in the CSD situation? Is the control position of the SAD comparable with the analytical permissive construction? In the case of inductive causation, preventing the occurrence of a situation is not relevant, as the agent typically strives for its completion. However, an implication of the idea of supreme control is that the causation can be seen as a hierarchical relationship instead of the linear causal chain. According to Leino (2003: 136), the questions in the testing of the ultimate controller are the following: which participant has more control over the situation? Who is responsible for the execution of the action denoted by the root verb? Is the supreme control external in respect to the root verb activity? I return to the questions of control and responsibility in chapters 4 and 5 in particular, as these features are essential to the semantics of CSDs.

The root verb in a causative derivative seems to have a relatively independent position, comparable to the infinitive component in the permissive construction. Based on the example of Finnish morphological causatives, Nikanne (1998) points out that each actor (or existence of an action tier) indicates an LCS of a verb. The CSDs thus have two actors in their LCS, and consequently also two action tier chains, both of them marking the boundary of a lexical item. Does a configuration with two actors indicate that the actor of the upper actor chain has the dominant position over the lower action tier? According to Givón (1974: 63), the control dynamics between the participants are expressed in grammar so that the object nominal may assume control only if the subject nominal has no control. As in the permissive construction, the SAD referent in a causative derivative with two animate arguments is the ‘explicit outside controller’, not taking part in the activity denoted by the root verb. Pajunen’s (2001: 146) observation supports this idea: although the causative morpheme is an additive modification, it demotes the status of the subject argument of the root verb, because the *t*-element in the *ttA*-morpheme indicates, in the same way as the Finnish passive marker *t*, that the agent is unknown, unspecified and unimportant. I return to aspects of dominance in connection with the discussion of the action tier of the CSDs in chapter 4 and in the CSD constructions in chapter 5.

Based on their form, causative constructions are traditionally divided into three types: (i) lexical (synthetic); (ii) morphological; and (iii) syntactic (analytic or periphrastic) (see for instance Shibatani & Pardeshi 2002). Dixon (2000: 30-31) emphasises the role of the added causer-argument in the event that a causative is formed by derivation and explains the causative construction as involving the specification of an additional argument onto a

---

<sup>24</sup>The primary meaning of the verb *antaa* is ‘to give’.

basic clause; this causer refers to someone or something that initiates or controls the activity. Importantly, these are among the properties also used to define the syntactic-semantic function of the transitive subject.

The CSD prototypes presented in the previous section could at first sight be argued to capture the causative derivatives according to the transitivity of the root verbs. This is how, for instance, Langacker (1991: 256-260) explains the correlation of causation and transitivity. The matters in this view are regarded as straightforward when the basic verb of a causative is intransitive: the predication simply expands from a one- to a two-participant event i.e. from  $[A \rightarrow]$  to  $[B \implies [A \rightarrow]]$ , functioning as a transitive clause in general. A causative based on a transitive verb then has the following abstract form:  $[C \implies [B \implies [A \rightarrow]]]$ . Consequently, in Langacker's view the syntactic notion of 'transitivity' and the semantic concept of 'causation' are in fact equal. This is not unusual within linguistic approaches to verb categorization, as these categories indeed often correlate; however, there are also cases where correlation is not present. There are, for instance, verbs that occur with an object but lack a causal effect (*ohittaa* 'to pass', *lukea* 'to read', *leikkiä* 'to play', *nähdä* 'to see', *kuulla* 'to hear', *tuntea* 'to know; feel' etc.). Consider the following examples; note that in sentences (3c-d) the situation is not controlled by the subject argument:

- (3a) *Matti ohitti talon*  
 Matti pass-past-3sg house-acc  
 'Matti passed the house.'
- (3b) *Matti lukee kirjaa*  
 Matti read-pres-3sg book-part  
 'Matti reads a book.'
- (3c) *Matti näkee puun*  
 Matti see-pres-3sg tree-acc  
 'Matti sees the tree.'
- (3d) *Matti tuntee kipua*  
 Matti feel-pres-3sg pain-part  
 'Matti feels the pain.'

In ISK (§461), the notion of transitivity is given the following definition: transitive verbs assign an object in addition to the subject and possibly also an adverbial complement; the prototypical transitive verbs are causative in their semantic content i.e. they express controlled or controllable action directed to an entity and causing a change in it, such as production verbs (Fi. *valmistamisverbit*) and treatment verbs (Fi. *käsittelyverbit*). Intransitive verbs in turn are defined as one-complement verbs that only assign the subject (§459). Additionally, intransitive are verbs that can have a subject and



adverbial complement but no object, like *sijaita* ‘to be located’ or *saapua* ‘to arrive’. Many intransitive verbs are also said to occur with an adverbial complement, object or both in some valence mould (*täydennysmuotti*, see section 2.4.1). However, the relative nature of verb transitivity is recognized in ISK by acknowledging that there are many verbs that occur at times with an object i.e. in a transitive clause, or without an object; some verbs also occur with a limited type of object. Also, P. Leino (2001) emphasizes the prototypical nature of verb transitivity – as a category it is not internally homogenous or clear.

Despite the recognition of transitivity as a relative phenomenon, it is used in ISK as the basic criterion for classifying causative derivatives. The division of Finnish morphological causative and curative verbs is stated in §462 as follows: the derivatives derived from intransitive verbs with the suffix *ttA* are causatives; the object of these verbs corresponds to the patient subject of the root verb, and in addition, an active subject is added (Fi. *tekijäsubjekti*): an agent. The verbs derived from transitive root verbs are curatives; these verbs express both the indirect causer (Fi. *teettäjä*) and the performer of the action which the instigator strives for. Hence, two close but different phenomena are here tightly intertwined; we can even say that these concepts are used to explain each other.

Transitivity can be described through a complex of features: Hopper and Thompson (1980) claim that transitivity is a basic relationship in language reflected in the morphosyntax of all languages. They have divided the notion of transitivity into ten components which determine the degree of transitivity in a clause. Thus, transitivity may be seen as a prototypical concept, a continuum of presence or absence of features. According to Hopper and Thompson, the aspects that are relevant for the concept of transitivity are the following:

Component parameters	High transitivity	Low transitivity
Participants	More than one participant	One participant
Kinesis	Action	Non-action
Aspect	Telic	Atelic
Punctuality	Punctual verb	Non-punctual verb
Volitionality	Volitional	Non-volitional
Affirmation	Affirmative	Negative
Mode	Realis	Irrealis; other moods
Potency of agent	Agent high in potency	Agent low in potency
Affectedness of object	Object totally affected	Object not affected
Individuation of object	Object highly individuated	Object not individuated

Also, ISK (§892 & §926) takes into account the transitivity continuum idea, emphasizing the role of the object referent regarding the degree to which the

effect of the agent's activity is realized on the object in an objective sentence. The conditions of maximal transitivity according to ISK are the following: the verb is dynamic, the agent +animate, the activity has an endpoint and the object is affected by the activity. However, it is unclear to what extent verb semantics can be used as a watertight criterion of transitivity: consider for instance verbs denoting autolocomotive motion like 'run' which express a dynamic motion, an activity that has an endpoint and encodes an active agent, but occurs without an object. Importantly, the transitivity parameters of Hopper and Thompson may just as well be applied to the concept of causation (recall the discussion earlier about the requirement of an active agent and a patient undergoing a change of state as well as the causative event descriptions focusing on the result and participants' mental state etc.).

A problem with the notion of transitivity is that it stands for different phenomena depending on the field in which it is handled. Wierzbicka (1996: 410) has summarized definitions of transitivity from different viewpoints. What she calls a structural definition of transitivity is any two-actant clause with a nominative (unmarked) subject and an accusative<sup>25</sup> object. By the semantic definition, transitivity is described as the effects of an action passed from agent to patient. However, Wierzbicka emphasizes that it is not justified to talk of transitive or intransitive actions, since the number of arguments does not follow on primarily from the number of participants partaking in events. According to the pragmatic transitive definition, the way in which speakers conceptualise the event is more relevant for the transitivity of clauses than directly linguistic aspects.

We can conclude that a verb classification based on both causation types and transitivity is problematic. Pajunen (2001:120) points out that the boundaries between causative verb classes are floating, because verbs do not lexicalize causation types clearly – a verb can express both volitional and physical causation (having both an agentive and non-agentive reading) or volitional and inductive reading. We saw above that inductive causation also includes volitionality, and that a single verb is able to undergo several causation types. How valid is the classification of verbs as intransitive and transitive verbs? According to Pajunen (2001: 285), high transitivity correlates with the accomplishment aspect type and low transitivity with the activity aspect type. However, a verb can generally occur in both telic and atelic situations, depending on the sentence type, and further, the referent of the patient word and the temporal-aspectual nature of the sentence depend on each other.

In this study, transitivity and causation are seen as categories of different levels of description. As the discussion above indicates, although transitivity

---

<sup>25</sup>The requirement of the accusative object is nevertheless invalid, at least in Finnish, where there are four object cases: accusative, nominative, genitive and partitive. The Finnish object is discussed in more detail in section 3.1.1.

and causativity often occur in parallel, this is not an automatic correspondence; therefore, there is reason to keep these complex phenomena apart. The semantic components of transitivity that repeatedly occur within different research (see for instance the table of Hopper & Thompson 1980 presented above) are analyzed in conceptual semantics on the semantic level. Causation and the phenomena related to it are divided in the conceptual semantics approach between different levels of description: dominance belongs to the action tier level, causation to the thematic tier; the aspectual nuances are described by thematic features, and some of the agentive properties (volitionality, responsibility and control) by semantic features. The types of causation are specified in the semantic fields. Direct and indirect causation are specified in the temporal tier as well as the temporal relation between the reason and the effect. Transitivity in this study stands for a special syntactic relationship between the verb and its arguments.

Causation is defined via a certain thematic relationship: ‘cause’ is a semantic function denoting that there are a causing event or causer and a caused event. Nikanne (2005) formalises the internal structure of causation as in (4):



An additional remark on causation: in my description of CSD prototypes, the causativity of the root verb is defined broadly i.e. a causative verb is not required to be a *ttA*-derived verb (sometimes this is an assumption in Finnish linguistic literature, as in the causative-curative classification of ISK presented above). By ‘causative root verb’ I mean a verb that expresses a causative event.

### 3 Syntactico-lexical linking and the argument structure of CSDs

It was discussed in section 1.2 that there are basically two different viewpoints on the categorization criteria of curative causatives or the Finnish *ttA*-causatives. On the one hand, transitivity of the root verb is considered a distinctive feature when dividing the curatives and other causatives into separate groups. The curative verb class is defined as causatives derived from transitive root verbs and including an adessive adjunct in their argument structure. The causatives derived from intransitive root verbs are regarded as basic causatives (ISK (2004: 455-456; 312), Hakulinen & Karlsson (1979: 242)). On the other hand, when the curative causatives are defined according to semantic criteria (the activity criterion and the non-participation criterion (see section 1.2)), the transitivity of the root verb becomes irrelevant (Kytömäki (1978), Pennanen (1984)).

My aim in this chapter is to study the syntactic behaviour of CSDs more closely and in this way to examine the effect of the transitivity criterion on the categorization of *ttA*-derivatives as either causative or curative verbs. The central question is: what kind of restrictions are there in the syntactic behaviour of deverbal causatives or CSDs in general? The discussion below is thus a review of the strong syntactic criteria used to constrain the derivative group of curative causatives. I focus on transitivity-based criteria and their validity in the classification of the curative verb class. Do these criteria describe lexical properties or more specific (or general?) rules? The curative sentence structure is the basis with which the different verbs are contrasted. I also study how naturally CSDs occur in sentence structures other than the subject-object-adessive adjunct type, the paradigm sentence structure of the curatives.

In section 3.1.3 I test the syntactic properties of CSDs derived from different types of root verbs in different sentential variations. The presence or absence of the object argument is crucial to the concept of transitivity. Therefore, before the syntactic test itself, the topic in section 3.1.1 is the Finnish object. As the characteristic syntactic component of the curative verb is considered to be the adessive adjunct, the rules that license the adessive adjunct assignment are discussed in section 3.1.2. The basic idea of the syntactic test in 3.1.3 is then to study the effect of varied sentential surroundings on the selected CSDs. To support the conclusions of syntactic regularities in section 3.1.3 as well as the linking relations between the conceptual structure and syntactic representation (sections 3.2-3.3), I have tested language users' intuition about the sentences in the syntactic test. The language instinct test is the subject of discussion in section 3.1.4; however,

the test results also form part of argumentation within the topics mentioned above.

The argument structure of CSDs is also the topic of the second part of this chapter. In order to identify the linking regularities between syntactic and semantic arguments, I examine the mapping between syntax and conceptual structure including the intermediate morpholexical level in section 3.2. We will see that the separation of these levels is useful in order to delimit the mapping relations between them. Section 3.3 is devoted to the conceptual analysis of the verbs undergoing the syntactic and language instinct tests of the first part of this chapter. Section 3.5 is a case study of a verb with flexible argument structure, *leikittää* ‘make s.o. play’.

### **3.1 Syntactic analysis. The transitivity effect of the root verb on derivatives**

#### **3.1.1 Discussion of the Finnish object**

The central factor regarding transitivity definitions is the existence of the phrasal object additional to the subject complement. This section is a brief overview of the characteristics of the syntactic object in Finnish.

The general semantic description of the prototypical object is ‘the complement in which the subject referent achieves or tries to achieve a change of state or place’. Characteristically, the object complement denotes the target or result of the activity (see for instance ISK §925, P. Leino 1991:37). In Finnish, the verbal object is considered to appear in three or four cases depending on the treatment of the grammatical cases. According to ISK (§81), the object can assign all of the structural cases of Finnish: nominative (ending  $\emptyset$  in the singular; *-t* in plural), genitive (*-n*; *-(d)en*, *-(t)ten*, *-in*), partitive (*-A*, *-(t)lA*; *-A*, *-(t)A*) and accusative ( $\emptyset$ ; *-n*; *-t*). All of these cases are regarded as grammatical i.e. they encode syntactic functions, not semantic or lexical. Noticeably, the accusative endings overlap with the nominative ending  $\emptyset$  and genitive ending *-n* in the singular as well as the nominative ending *-t* in the plural. This is a source for different accounts of the object case assignment within literature. One solution is to unite the accusative case marking with the genitive and nominative cases as in Vilkuna (1996:83); the objective cases are then nominative, partitive and genitive. The accusative case can also be seen as inclusive of the (genitive) *-n* cases (see Nikanne 2006: 216), in which case the object case marking system includes the nominative, partitive and accusative. An account distinguishing all four objective cases (like the abovementioned object description of ISK) considers the accusative as a case of personal pronouns referring to humans only.

There are syntactic restrictions for the nominative and partitive as object cases in that the object of an imperative sentence can assign the nominative

case and the object of a negative sentence always assigns the partitive case. Consider example (1) of an imperative predicate and a negation in (2):

- (1) *Lukekaa kirja!*  
 read-imperative-2pl book-nom  
 ‘Read the book!’
- (2) *Matti ei lue kirjaa.*  
 Matti neg-3sg read book-part  
 ‘Matti does not read the book.’

According to Vainikka (1993), the accusative case is assigned by the feature <+completed> in connection with the verbs encoding this feature. Because there is nothing else that assigns the accusative, and there is no overt suffix unique to it (except the *-t* in the case of personal pronouns), its status is different from the partitive case. Other structural cases are markers of specific syntactic positions, like the replacement of the accusative object with the partitive object when the sentence is negative. Object case marking in Finnish, except in connection with negation, is influenced by aspectual case marking. The general practice is to distinguish between a ‘partial object’ (in the partitive case) and a ‘total object’ (other object cases): the partitive object indicates that a situation is an unbound unity expressing an incomplete event, whereas the accusative object marks a completed, bound event (Hakulinen & Karlsson 1979, P. Leino 1991, Toivainen 1993, ISK §925 and Nikanne 2006). The opposition of partial and total object can be seen in (3):

- |  |   |
|--|---|
| (3) TOTAL OBJECT   | PARTIAL OBJECT  |
| Affirmative, telic sentence,<br>quantitatively definite object | Interpreted as a negative sentence,<br>atelic sentence, quantitatively<br>indefinite object |

ISK (§892) suggests that sentences with a partial object are less transitive than sentences with a total object. This idea stems from the well-known fact that the case marking of the object and the adverbials in object cases are central means to express aspectual nuances in Finnish (Hakulinen & Karlsson 1979: 183). According to Pajunen (2001: 285), high transitivity correlates to the achievement aspect type and low transitivity to the activity aspect type. Since a verb generally is able to occur in both aspect types in Finnish, for instance through object case alteration, we can ask how justified the division of verbs into transitive and intransitive verbs is. Consider sentences (4) and (5):

- (4) *Matti lukee kirjan*  
Matti read-pres-3sg book-acc  
'Matti reads the book (from cover to cover).'
- (5) *Matti lukee kirjaa*  
Matti read-pres-3sg book-part  
'Matti is reading the book.'

Since the aspectual case marking is not the central topic but is involved to some extent in analysis of CSD sentences, I use the division of nominative and accusative to mark the total object in this study; the partitive is the case for the partial object.

There are certain adverbials in Finnish which, in addition to the ordinary object, assign the object cases and show the same case alternations between the partitive and other object cases that verbal objects do. These adverbials usually express some kind of amount, like measure, duration, distance and frequency, and are called 'adverbials of amount in object cases' (Fin. *objektin sijainen määrän adverbiali*, often abbreviated to 'osma') (for adverbials of amount, see ISK (§972-§973) and Vilkuna (1996: 85)). As ordinary objects, adverbials of amount also contribute to aspectual case marking in Finnish. Examples (6a-d) illustrate the different types of adverbials of amount:

- (6a) *Matti maksoi kirjasta 20 euroa*  
Matti pay-past-3sg book-ela 20-nom euro-part  
'Matti paid 20 euros for the book.'
- (6b) *Matti juoksi tunnin ajan*  
Matti run-past-3sg hour-acc time-acc  
'Matti ran for an hour.'
- (6c) *Matti juoksi koko matkan*  
Matti run-past-3sg whole way-acc  
'Matti ran the whole way.'
- (6d) *Matti huusi kolme kertaa*  
Matti yell-past-3sg three-nom time-part  
'Matti yelled three times.'

There is an additional subgroup of objects: 'cognate objects'. These are considered to connect to verbs that usually appear without an object and emerge as stems lexically cognate with the verb (as in the English 'dance a dance'); also, the semantic similarity between the verb and the object can be seen as a criterion of the cognate object (as in the English 'weave a fabric') (ISK § 929; P. Leino 1991: 37). However, the definition of the concept of the cognate object seems to be somewhat arguable. On the one hand, the cognate object fills, both syntactically and semantically, the regular object criteria. On

the other hand, the semantic similarity between the verb and the object is a diffuse criterion, because the object referent tends to be associated with the verb meaning<sup>26</sup>.

Wiik (1972) argues that there is a hierarchy that determines object case assignment in Finnish, since the language generally avoids the occurrence of the same case more than once in a sentence. He suggests that the principle governing assignment is as follows: the nominative case is available for the subject; if the subject is assigned another case, the nominative case is available for the object. Maling's (1993: 60) account also takes adverbials of amount into consideration. She argues that there are differences within adverbials of amount in their objective qualities, the measure phrases being most object-like, followed by duration (DUR) and frequency phrases (FREQ). The case hierarchy and distribution of the nominative and accusative cases and syntactic functions can be seen in (7):

(7) SUBJ > OBJ > MEASURE > DUR > FREQ

Finnish thus enables users to vary sentences using different types of objects in the sense that even if there is no typical object available, an adverbial of amount, for example, can take its place and functions.

### 3.1.2 Adessive adjunct and argument fusion

According to Nikanne (1997: 342-343), adjunct constructions can generally be divided into two types: 'fill-in adjuncts' and 'add-on adjuncts'. Fill-in adjuncts express an argument that is lexically marked as implicit. These are not syntactic arguments, but are linked to a verb's semantic argument by an argument construction. Add-on adjuncts in turn are not part of the core sentence, but instead add something to its meaning. The argument structure of CSDs (see the prototype 1 structure in section 2.4.2) includes a conceptual argument that does not have to be expressed syntactically in order to be well-formed. This implicit adjunct, morphologically marked with the adessive case, expresses the actor and performer of the action denoted by the root verb. The adessive adjunct is linked to the SAR at the morpholexical level. The implicit agent of CSDs can thus be classified as a fill-in-adjunct. Siro (1996: 175) explains the transfer of an agent to an oblique constituent as licensed by the rule of Finnish: the syntactic object and agent cannot be

---

<sup>26</sup>For instance Siro's (1975:58) definition of the cognate object (Fin. *sisällönobjekti*) is that an otherwise intransitive verb's object represents the same concept as the verb itself. Nevertheless, the entity an object refers to is quite often related to the verb's meaning; thus it is unclear where the limits between a 'proper' object and cognate object fall ('build a house', 'sew a dress', 'write a letter/note', 'dance a dance/waltz' etc.).



identical on the surface level; if an agent cannot be expressed in syntax as a subject or an object, it can be transferred to the adessive oblique position.

The Finnish adessive case is marked by the ending *-lla* and is considered to be one of the external locative cases. The basic meaning of the adessive is thus the locative ‘at’ or ‘on’ (*Kirja on pöydä-llä* ‘The book is on the table’). The adessive case is also used to express instrumentality and manner in Finnish. The instrumental adessive phrase can be mapped to the theme argument in the CS, which is licensed by the ‘adessive rule’ articulated in Nikanne (1990: 141)<sup>27</sup>: if there is an implicit theme argument in the lexical entry of a verb, the adessive NP can be fused with it. Example (1) illustrates this rule: the implicit theme of the verb *voidella* ‘to butter’ i.e. ‘butter’ is fused with ‘margarine’ (the implicit argument treatment in conceptual semantics is also discussed in 2.2.1 and 2.2.2).

- (1) *Matti<sub>1</sub> voitelee<sub>2</sub> leivän<sub>4</sub> margariinilla<sub>3</sub>*  
 Matti butter-pres-3sg bread-acc margariini-ade  
 ‘Matti butters the bread with margarine.’

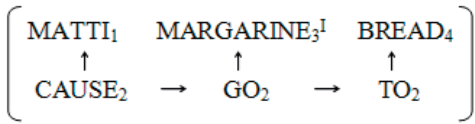

The adessive rule presented above concerns adjuncts fused to zone 2 arguments. The adessive adjunct encoding the performer of the action in connection with CSDs is mapped to an implicit argument of the second cause-function. Consider a CSD sentence expressing the adessive adjunct in (2):

- (2) *Opettaja<sub>1</sub> luetuttaa<sub>2</sub> Matilla<sub>3</sub> kirjan<sub>4</sub>*  
 teacher read-caus-pres-3sg Matti-ade book-acc  
 ‘The teacher makes Matti read the book.’

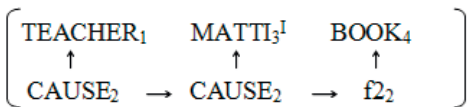

Hence the adessive adjunct can even be mapped to a zone 3 function if it has the value of an agent. Nikanne (1990: 149) generalizes the assignment of the adessive adjunct in the following rule, where Z stands for zone:

<sup>27</sup>As Nikanne points out, the Finnish adessive rule corresponds to the with-theme rule in Jackendoff (1990).

“If V has one or more implicit theta-arguments ( $Z > 1$ ) and a lexicalized goal-path function, then  $[_V V \dots [_{PP} [_P ADE [NP]]]]$  may correspond to a structure where the interpretation of the NP is fused with one of the implicit theta arguments.”

The Finnish adessive adjunct rule can thus be encapsulated in the following structure:

$$(3) \left( \begin{array}{c} X_i + ADE \\ \dots ]_i \\ \uparrow \\ \dots f > 1 \dots \end{array} \right)$$

### 3.1.3 Test of the syntactic behaviour of CSDs

In this section I focus in particular on the influence of the argument structure of the root verb on the characteristics of the derivative and the syntactic behaviour of CSDs. What are the actual differences between CSDs with varied root verb properties, and what generalizations can we make? How do CSDs adapt to different sentence surroundings? The central means in examining the root verb’s effect on the derivative is the morpholexical level and morphological roles introduced in section 2.2.2. The questions relevant to the syntactic study of *ttA*-causatives are the following:

- Is the adessive adjunct SAR only possible in connection with causatives derived from transitive root verbs?
- Can the SAR be expressed with both the adessive and object cases by the same CSD?
- When is the SAR expressed in object cases? Is there a difference regarding partial vs. total object alternation of the SAR in object cases in a CSD sentence?
- What is the role of the OAR in a CSD sentence?
- How does the alteration of sentential surroundings affect the lexical argument structure of CSDs? What does it tell us about the lexical representation of a verb?

To explicate the effect of the root verb argument structure I test six CSDs in different sentential surroundings. The CSDs in the test are the following: *ompeluttaa* ‘make s.o. sew’ (1), *teettää* ‘make s.o. do’ (2), *syötättää* ‘make s.o. eat’ (3), *laulattaa* ‘make s.o. sing’ (4), *juoksuttaa* ‘make s.o. run’ (5) and *jonotuttaa* ‘make s.o. queue’ (6) (see the syntactic test of six CSDs p. 106-107). The grounds for my verb selection are provided by the Finnish verb

division of Pajunen (2001: 283-288, tables 33 and 34). This verb classification strives for an outline based on the primary argument places and the semantic properties of the arguments. The aim of her classification is to show how semantic transitivity correlates with the verb complement types and semantic characteristics of the Finnish verbs. The basis of the analysis is that the semantic properties of the participants are defined; this approach is thus comparable with the graded transitivity concept of Hopper and Thompson (1980) (compare to the transitivity component parameters in section 2.5). The selected causative derivatives represent verbs with varied transitivity value. Note that according to Pajunen's Table 33, which categorises transitive verbs with two or three argument places like *tappaa* 'to kill' and *rikkoa* 'to break', CSDs derived from the most transitive verbs are not included in this test because they are highly lexicalised and behave rather idiosyncratically. I analyse the verb *tapattaa* 'make s.o. kill' as a special case in section 5.3.3. I have also left out the the experience verbs (*ajatella* 'to think', *tuntea* 'to feel'), part-whole verbs (*koskettaa* 'to touch', *lyödä* 'to hit'), transaction verbs (*antaa* 'to give', *kuljettaa* 'to ferry') and location/instrumental verbs (*haravoida* 'to rake', *siivota* 'to clean') from Pajunen's Table 33.

The root verbs of the causatives in the test follow the transitivity scale starting from high transitive verbs to low transitive verbs. The root verb of the first CSD in my test, *ommella* 'to sew', belongs to the high transitive verb group according to Pajunen's classification. It is a 'production verb' (Fin. *valmistusverbi*) with a strong agent as the actor-argument (the SAR), and an 'affected' patient (theme) as the second argument (the OAR). The patient is the result of the activity; it would not exist without the action denoted by the root verb. The second CSD, *teettää* 'make s.o. Do', was chosen because of the strong transitivity degree of its root verb and because it is a frequent curative verb – it can even be seen as a hyperonym of the curatives because of its generic character (in the meaning 'obtain a service from somebody'). The object referent of the root verb *tehdä* 'to do, make' has a relatively wide denotation, and the agent-patient characteristics are similar to *ommella* 'to sew'.

The root verb of the third CSD, *syödä* 'to eat', is characterised by a strong agent, but the patient (theme) is implicit. This verb expresses activity, and sometimes also a change. The root of the next verb, *laulaa* 'to sing', has similar characteristics to *syödä*, with the difference that the patient does not undergo a change. The root of the fifth verb, *juosta* 'to run', is classified in Pajunen's Table 34 (which only includes verbs with one complement) as a motion verb denoting fixed motion (Fin. *kiinteä liike*). *Juosta* represents verbs expressing motion caused by one's own force. As the root verb of the last CSD in the test, I have chosen *jonottaa* 'to queue'. This is also a single-complement verb, but in contrast to *juosta* it denotes a static situation, not

activity<sup>28</sup> (for the characteristics of selected verbs, see Pajunen 2001: 283-288.) Altogether, three of the six root verbs of the selected CSDs – *ommella* ‘to sew’, *tehdä* ‘to do’ and *jonottaa* ‘to queue’ – are not taken directly from Pajunen’s tables, but the verb characteristics are considered to correspond to the requirements of this classification.

The six CSD verbs in my test can be subcategorised further into three groups. The first two verbs, *ompeuttaa* ‘make s.o. sew’ and *teettää* ‘make s.o. Do’, are both derived from highly transitive roots and can be classified as production verbs, with the difference being that the denotation of the object referent of *ompeuttaa* is more restrictively specified than that of *teettää*; ‘make s.o. do’ is a general ‘outsourcing’ verb with a large extension. The second group represents causatives derived from verbs with an implicit theme, *syötättää* ‘make s.o. eat’ and *laulattaa* ‘make s.o. sing’. Note that *syötättää* includes two *ttA*-morphemes; the derivative form *syöttää* has generally lexicalised in the meaning of ‘to feed’. The third group comprises verbs with single-argument roots. I refer to these groups as ‘high transitivity verbs’, ‘medium transitivity verbs’ and ‘low transitivity verbs’.

The morpholexical terms SAR (subject argument of root verb), SAD (subject argument of derived causative verb) and OAR (object argument of root verb) are used in the analysis below to distinguish between the argument level of the root verb and the derivative level. An additional term is also needed: OAD (object argument of derivative), standing for an object less tightly connected to the verb. The selected verbs are tested in 6 different sentential surroundings. The sentence structures are constructed as follows:

- a) The a-sentences are ‘complete’ curative sentences with a subject, object and adessive adjunct, where the SAR is the adessive adjunct (SARade) and the OAR or the OAD is the object in both the partitive and accusative cases, e.g.:

*Matti haetuttaa Pekalla kirjan/kirjaa.*

Matti fetch-caus-pres-3sg Pekka-ade book-acc/-part  
‘Matti makes Pekka fetch the book.’

- b) The b-sentences lack the adessive adjunct; the SAR is not expressed syntactically. The OAR or the OAD is expressed if the base verb can have an object argument. If not, a semantically/syntactically suitable modifier in the object cases is used, e.g:

*Matti haetuttaa kirjan/kirjaa.*

Matti fetch-caus-pres-3sg book-acc/-part  
‘Matti makes [s.o.] fetch the book.’

<sup>28</sup>Note that despite the *ttA*-suffix, the verb *jonottaa* is not causative.

- c) In the c-sentences, the SAR is expressed in the partitive case (SARpart); the partial object makes the whole sentence atelic. The OAR or the OAD is not expressed, e.g.:
- Matti haetuttaa Pekkaa.*  
 Matti fetch-caus-pres-3sg Pekka-part  
 ‘Matti makes Pekka fetch.’
- d) The SAR is expressed as the adessive adjunct (SARade) and the OAR or the OAD is not expressed, e.g.:
- Matti haetuttaa Pekalla.*  
 Matti fetch-caus-pres-3sg Pekka-ade  
 ‘Matti makes Pekka fetch [s.t].’
- e) The e-sentences are resultative constructions with the SAR as the accusative object (SARacc). The result is expressed using a translative or illative adjunct, e.g.:
- Matti haetuttaa Pekkan väsyneeksi.*  
 Matti fetch-caus-pres-3sg Pekka-acc tired-tra  
 ‘Matti tires Pekka out fetching.’
- f) Finally, the f-sentences include the SAR in the accusative case (SARacc); it is the total object and makes the sentence telic. The OAR or the OAD is not expressed, e.g.:
- Matti haetuttaa Pekkan.*  
 Matti fetch-caus-pres-3sg Pekka-acc  
 ‘Matti makes Pekka fetch.’

The morphoroles and their case markings in the test sentences can be seen as the following structures:

- a) [SAD, OAR/OAD, SARade]  
 b) [SAD, OAR/OAD]  
 c) [SAD, SARpart]  
 d) [SAD, SARade]  
 e) [SAD, SARacc, RESADJtra/ill]  
 f) [SAD, SARacc]

The alternation of sentential constituents and their case markings is designated so as to establish the syntactic structure of the selected verbs. The c- and f-sentences differ only in the case marking of the SAR in the object position (the partitive in c-sentences and the accusative in f-sentences) with the purpose of determining whether there are differences between the SAR’s appearance as partial and total objects. The case alternation of OAR is not the focus here; thus the sentences that have an OAR are marked with both the

accusative and partitive cases in the test. The resultative construction (e-sentences) adds a modifier to the sentence; it is chosen to additionally affect the syntactic environment and to test the flexibility of these verbs' argument structure. The resultative sentence type expresses the accomplishment term in Vendler's (1967) terms. Resultativity in Finnish is expressed by a resultative verb stem, the accusative object case, by a certain verbal derivative suffix or syntactically by means of the resultative construction (Pajunen 2001: 154). As ISK (2004: 154) points out, the resultative construction modifies the sentence, so it becomes more transitive by assuring the accomplishment of the effect on the patient; generally, a high transitivity verb in Finnish changes the aspect type by means of object cases, whereas a low transitivity verb can in addition be used in the resultative construction.

The selected verbs in six different sentential surroundings are presented in (1)-(6). Note that two argument referents are constant in respect to their morphorole linking through the sentences: Matti = SAD and Pekka = SAR. The OAR referents vary in order to conform to the meaning of the verbs and to modify the aspectual meaning of the sentences. The distinction between ungrammatical and grammatical sentences in (1)-(6) is not an unambiguous matter. The sentences marked with (#) do not indicate that the sentences are completely unacceptable; the unmarked sentences are correct in the sense that we do not need to know more about the context, whereas the marked sentences are only acceptable in certain situations.

## Syntactic test of six CSDs

### I High transitivity verbs

(1) *ompeluttaa* 'make s.o. sew': *ompele* + *ttA* [sew-caus]

a. Matti ompeluttaa Pekalla puvun/pukua.	Matti sew-caus-3sg Pekka-ade dress-acc/-part
b. Matti ompeluttaa puvun/pukua.	Matti sew-caus-3sg dress-acc/-part
c. #Matti ompeluttaa Pekkaa.	Matti sew-caus-3sg Pekka-part
d. #Matti ompeluttaa Pekalla.	Matti sew-caus-3sg Pekka-ade
e. #Matti ompeluttaa Pekan komeaksi.	Matti sew-caus-3sg Pekka-acc handsome-tra
f. #Matti ompeluttaa Pekan.	Matti sew-caus-3sg Pekka-acc

(2) *teettää* 'make s.o. do': *teke* + *ttA* [do-caus]

a. Matti teettää Pekalla talon/taltoa	Matti do-caus-3sg Pekka-ade house-acc/-part
b. Matti teettää talon/taltoa.	Matti do-caus-3sg house-acc/-part
c. #Matti teettää Pekkaa	Matti do-caus-3sg Pekka-part
d. #Matti teettää Pekalla.	Matti do-caus-3sg Pekka-ade
e. #Matti teettää Pekan aikuiseksi.	Matti do-caus-3sg Pekka-acc adult-tra
f. #Matti teettää Pekan.	Matti do-caus-3sg Pekka-acc

## II Medium transitivity verbs

### (3) *syötättää* ‘make s.o. eat’: *syöttä + ttA* [eat-caus-caus]

a. Matti syötättää Pekalla puuron/puuroa.	Matti eat-caus-3sg Pekka-ade porridge-acc/-part
b. Matti syötättää puuron/puuroa.	Matti eat-caus-3sg porridge-acc/-part
c. Matti syötättää Pekkaa.	Matti eat-caus-3sg Pekka-part
d. #Matti syötättää Pekalla.	Matti eat-caus-3sg Pekka-ade
e. Matti syötättää Pekan kylläiseksi.	Matti eat-caus-3sg Pekka-acc full-tra
f. Matti syötättää Pekan.	Matti eat-caus-3sg Pekka-acc

### (4) *laulattaa* ‘make s.o. sing’: *laula + ttA* [sing-caus]

a. Matti laulattaa Pekalla joululaulun/joululaulua.	Matti sing-caus-3sg Pekka-ade Christmas.carol-acc/Christmas.carol-part
b. Matti laulattaa joululaulun/joululaulua	Matti sing-caus-3sg Christmas carol-acc/Christmas carol-part
c. Matti laulattaa Pekkaa.	Matti sing-caus-3sg Pekka-part
d. #Matti laulattaa Pekalla.	Matti sing-caus-3sg Pekka-ade
e. #Matti laulattaa Pekan iloiseksi.	Matti sing-caus-3sg Pekka-acc glad-tra
f. Matti laulattaa Pekan.	Matti sing-caus-3sg Pekka-acc

## III Low transitivity verbs

### (5) *juoksuttaa* ‘make s.o. run’ *juokse + ttA* [run-caus]

a. Matti juoksuttaa Pekalla lenkin/lenkkiä	Matti run-caus-3sg Pekka-ade turn-acc/ -part
b. #Matti juoksuttaa lenkin/lenkkiä.	Matti run-caus-3sg turn-acc/-part
c. Matti juoksuttaa Pekkaa.	Matti run-caus-3sg Pekka-part
d. #Matti juoksuttaa Pekalla.	Matti run-caus-3sg Pekka-ade
e. Matti juoksuttaa Pekan kaupunkiin/uuvuksiin	Matti run-caus-3sg Pekka-acc city-ill/exhausted-ill
f. #Matti juoksuttaa Pekan.	Matti run-caus-3sg Pekka-acc

### (6) *jonotuttaa* ‘make s.o. queue’ *jonotta + ttA* (queue-CAUS)

a. #Matti jonotuttaa Pekalla tunnin/*tuntia.	Matti queue-caus-3sg Pekka-ade hour-acc
b. Matti jonotuttaa tunnin.	Matti queue-caus-3sg hour-acc
c. Matti jonotuttaa Pekkaa.	Matti queue-caus-3sg Pekka-part
d. #Matti jonotuttaa Pekalla.	Matti queue-caus-3sg Pekka-ade
e. Matti jonotuttaa Pekan uuvuksiin.	Matti queue-caus-3sg Pekka-acc exhausted-ill
f. #Matti jonotuttaa Pekan.	Matti queue-caus-3sg Pekka-acc

We can say that the sentences presented in the syntactic test represent clear cases and less clear cases; the clear cases, of course, are not impugned by the unclear cases (as argued in Itkonen 2006). The difference between these two types is that a *clear* case indicates a case marking that does not

require special stipulation, while an *unclear* case indicates a proposition that requires additional contextual information. The #-sentences cannot be labelled as impossible or bad – language is adaptable to even incoherent and unexplainable situations in a suitable context (as for instance in fairytales). For instance, sentences (1c, 1e and 1f) seem odd at first glance, but in a situation where Matti somehow directed/referred Pekka to plastic surgery to get his nose sewn back in the right place after an accident, these sentences would be adequate. Sentence (1d) would be acceptable if someone emphasized that it was not Tom that sewed the suit but Pekka. Sentences (2c, e and f) describe a more unlikely situation (for instance *Matti teittää Pekkaa* ‘Matti is having Pekka done’ (2c)). At first it might be associated with a science fiction-like cloning situation or a Frankenstein situation. Also, (3f) *Matti syötättää Pekan* ‘Matti makes Pekka eat’ could be associated with a situation where Pekka is a hospital patient unable to eat by himself and Matti has the express responsibility of feeding Pekka. Sentences (4d and 4f) with *laulattaa* ‘make s.o. sing’ could be used in an educational situation – for instance, a choir conductor could be in the habit of having new members sing a Christmas carol as a test.

What does the syntactic test reveal about syntactic variation and the placement of root verb arguments? With regard to their clearness in different sentence types, there are variations among CSDs. A certain pattern can be traced in their behaviour depending on the transitivity grade of the root verbs of the tested verbs. Since the test sentences are not divided into grammatical and non-grammatical, I treat these patterns as tendencies. According to the examples above, the following inferences can be made based on the behaviour of different kinds of CSDs:

**I:** The assignment of the SAR in object cases is restricted. **The SAR of the causatives in the high transitivity group (verbs (1) and (2)) does not naturally occur in object cases but only in the adessive case.** Object cases are, by default, the cases reserved for the OAR. Vice versa, an argument in an object case is interpreted as the OAR, not the SAR (see 1c, 2c, but 3c) unless the context implies otherwise.

**II:** The CSDs of the medium and weak transitivity group can have the SAR in the adessive case or in object cases (see 4a, 4c, 4e and 5a, 5c and 5e). But there is a restriction – **the SAR can only occur in the adessive when a complement in the object case is present in the argument structure of the CSD** (compare the a-sentences to the d-sentences). The generalization we can make is that if the OAR or another element in the object position (the OAD) is syntactically expressed, the SAR can be in the adessive.



**III:** The SAR is expected to be expressed syntactically in the default case with derivatives that have intransitive root verbs without implicit themes (to dance a dance, to sing a song) in their structure; the SAR of derivatives with transitive root verbs is optional (see 5b and 6b, compared to 4b)<sup>29</sup>. Thus, the SAR has a syntactically higher position in causatives that have intransitive roots by assigning object cases. The OAR of a transitive root is higher ranked than the SAR, and maintains the object position even after the derivation process; the root verb brings the OAR to the derivative.

In general, verbs regarded as high transitives and low transitives derived as CSDs are most restricted in their ability to adapt different sentential surroundings. The second group with medium transitivity verbs (*syötättää/laulattaa*) in turn displays the highest flexibility in syntactic behaviour.

Comparing all of the a-sentences, we can see that the curative construction is acceptable with almost all of the verbs in the test – an adessive adjunct and an object or a provisory object function well together in different types of CSDs. Only (6a), the full ‘curative’ sentence with the low transitivity CSD *jonotuttaa* ‘make s.o. queue’, is somewhat out of the ordinary. In a context where Matti has Pekka queue for some of the time in a long queue, the adverbial time-expression takes the object’s place, but a more information-bearing object seems to be needed here.

The b-sentences that lack the SAR are most natural in the case of high transitivity verbs, but medium transitivity verbs also seem to adapt this sentence type well. Low transitivity verbs do not automatically function well in this argument structure, but require an overt SAR. High transitivity verbs in turn do not adapt atelic c-sentences naturally; the SAR cannot take the object place without an explanatory context. The weak transitivity CSDs function well in a c-sentence i.e. in a sentence where the SAR assigns the partitive object. All of the tested verbs are marked as unclear in the d-sentences – the SARade without a filled object place is not a very natural sentence without a special context. This is a consequence of the fact that a CSD itself is highly transitive and requires a linguistic element as object place filler.

The e-sentences are resultative constructions with a result in either the translative or the illative case. The verbs in the high transitivity group do not naturally adapt the resultative construction with the SAR as the object (see (1e) and (2e))<sup>30</sup>. The low transitivity verbs (5e) and (6e) adapt the resultative construction well, as does *syötättää* ‘make s.o. eat’ in the medium transitivity group (3e). Note that the result in the translative case seems to be more

---

<sup>29</sup>Sentence (5b) is quite clear if the SAR is understood in a generic sense.

<sup>30</sup> Comparing for instance (1e) to the sentence where the OAR (*puku* ‘dress’) is the resultative object (*Matti ompeluttaa puvun komeaksi* [Matti sew-caus-3sg dress-acc handsome-tra]) instead of the SAR (Pekka), this is quite a natural sentence.

characteristic of the first two groups ((1)-(4)), whereas in the last group ((5) and (6)) the illative case, denoting the endpoint of spatial or temporal movement, is more typical. The last sentence type (f) with the SAR as a total object in the accusative case and no syntactically expressed OAR is an unclear sentence of high and low transitivity CSDs; the medium transitivity group is acceptable in this structure. A general observation is that medium and low transitivity verbs seem to assign the SAR more naturally in the partitive than the accusative; high transitivity verbs are unclear in terms of both the accusative and partitive SAR. Can the partitive SAR be considered the default with low and medium transitivity verbs? When it comes to the resultative construction, do different types of CSDs take different kinds of resultative adjuncts? I leave these questions for future research.

We have seen that the clarity of a sentence depends partly on syntactic well-formedness principles. On the other hand, the configuration of root verb arguments (morphoroles) and how these are situated in the derivative structure has an influence on semantics. Merely syntactically, the differences between the different types of CSDs in the test are not significant – the syntactic structure of CSDs derived from different types of root verbs is basically similar. Compare the analyses in (7a)-(8b), where (7a-b) are sentences using the CSD *ompeluttaa* ‘make s.o. sew’, derived from a high transitivity root verb with and without the SARade and 8(a-b) represent the same sentence types with the low transitivity CSD *juoksuttaa* ‘make s.o. run’, respectively. Note that the difference between (7b) and (8b) lies in the morphorole linking – the object NP is linked to the OAR in (7b) and to the SAR in (8b), respectively.

(7a) *Matti ompeluttaa Pekalla puvun*

Matti sew-caus-3sg Pekka-ade dress-acc  
‘Matti makes Pekka sew the dress.’

[<sub>IP</sub> [<sub>NP</sub> Matti] [<sub>I'</sub> [<sub>V-I</sub> ompeluttaa] [<sub>VP</sub> [<sub>PP</sub> Pekalla] [<sub>V'-v</sub> [<sub>NP</sub> puvun]]]]]

(7b) *Matti ompeluttaa puvun*

Matti sew-caus-3sg dress-acc  
‘Matti makes s.o. sew the dress.’

[<sub>IP</sub> [<sub>NP</sub> Matti] [<sub>I'</sub> [<sub>V-I</sub> ompeluttaa] [<sub>VP</sub> [<sub>V'-v</sub> [<sub>NP</sub> puvun]]]]]

(8a) *Matti juoksuttaa Pekalla lenkin.*

Matti run-caus-3sg Pekka-ade turn-acc  
‘Matti makes Pekka run a turn.’

[<sub>IP</sub> [<sub>NP</sub> Matti] [<sub>I'</sub> [<sub>V-I</sub> juoksuttaa] [<sub>VP</sub> [<sub>PP</sub> Pekalla] [<sub>V'-v</sub> [<sub>NP</sub> lenkin]]]]]

(8b) *Matti juoksuttaa lenkin.*

Matti run-caus-3sg turn-acc

‘Matti makes s.o. run a turn.’

[<sub>IP</sub> [<sub>NP</sub> Matti] [<sub>I'</sub> [<sub>V-I</sub> juoksuttaa] [<sub>VP-V</sub> [<sub>V'-V</sub> [<sub>NP</sub> turn]]]]]

The analysis above demonstrates that there is syntactically no significant difference in the result of the transitivity process by which an additional argument is added to the proposition. Another aspect is that regardless of the transitivity grade of the root verb, a CSD is able to adjust to the curative sentence. This indicates that verbs can potentially operate as transitives in the sense that they can take more or less typical objects.

I assume that this analysis of syntactic properties is sufficient for present purposes. It shows that the syntactic structures of causatives derived from transitive and intransitive root verbs are basically similar. This supports the idea that it is more beneficial to treat syntax and semantics as autonomous levels and strive for integration by identifying linking relations. I study the conceptual structure of high, medium and low transitivity CSDs as well as the linking relations between the DA system, morphorole level and LCS in sections 3.2-3.5. Before this, the inferences drawn from the syntactic test concerning the argument structure of CSDs is contemplated in light of an acceptability rating test: in section 3.1.4, language users' assessment of some of the sentences taken from the syntactic test are confirmed. In this way, the morphorole linking effect is also more closely examined.

### 3.1.4 Language instinct test

The syntactic test discussed in previous section indicates that there are certain restrictions regarding the morphorole and syntactic argument linking of different types of CSDs. I will now introduce a new viewpoint regarding the syntax-semantic relations of CSDs by checking language users' intuition about the syntactic structure variations examined in the previous section. One aim of the language instinct test is to see how language users support the labelling of the sentences as clear/unclear; the interpretation of the less clear sentences is especially important. Consideration of the point of view of language use is designated as an extra complement to the study of CSDs<sup>31</sup>. I expect that this will open up new aspects of the argument structure study. Naturally, examination of the concrete expression of native language user

<sup>31</sup>Alpo Räisänen (1983: 112-137) has tested language instinct in order to outline language users' ideas of the relation between the root word and the derivative. His results indicate that besides the traditionally understood derivation, there exists a 'correlation derivation' (Fi. *korrelaatio-johto*), based on models of already existing derivative relations and model derivatives. This explains the 'lack' of root words and gaps in derivative chains.

output widens the view on the conclusions drawn in the analysis of the syntactic test, based solely on my linguistic judgement.

In order to determine how language users interpret the alternation of the argument structures of CSDs, I compiled a survey consisting of 18 sentences from the syntactic test discussed in the previous section. The test included 3 of the 6 verbs used in the syntactic test and involved the same sentential surroundings (a- through f-sentences, see section 3.1.3). The verbs in the test were *ompeluttaa* ‘make s.o. sew’, *syöttää* ‘make s.o. eat’ and *jonotuttaa* ‘make s.o. queue’, representing one verb from each transitivity group. The survey had two main tasks. Firstly, the test subjects were asked to assess the acceptability of the sentences on a scale from 0-10. The second task was to paraphrase the test sentences. The purpose of paraphrasing was to show how these sentences were interpreted and to explicate the interpretation of the argument structure of the verbs in the test. The order of the sentences and verbs in the language instinct test was randomised i.e. it did not follow the order of the syntactic test. The test sentences are presented in (1). In order to facilitate comparison with the syntactic test, I here give the test sentence numbers in parenthesis and mark the test sentence numbers with a *t*-letter (for instance (t1a)).

(1)

1) Matti ompeluttaa Pekalla puvun/ pukua. (t1a)	Matti sew-caus-3sg Pekka-ade dress-acc/-part
2) Matti jonotuttaa Pekkaa. (t6c)	Matti queue-caus-3sg Pekka-part
3) Matti ompeluttaa Pekan komeaksi. (t1e)	Matti sew-caus-3sg Pekka-acc handsome-tra
4) Matti syöttää Pekan. (t3f)	Matti eat-caus-3sg Pekka-acc
5) Matti jonotuttaa tunnin. (t6b)	Matti queue-caus-3sg hour-acc
6) Matti syöttää Pekalla puuron. (t3a)	Matti eat-caus-3sg Pekka-ade porridge-acc
7) Matti ompeluttaa puvun. (t1b)	Matti sew-caus-3sg dress-acc
8) Matti jonotuttaa Pekalla tunnin. (t6a)	Matti queue-caus-3sg Pekka-ade hour-acc
9) Matti ompeluttaa Pekan. (t1f)	Matti sew-caus-3sg Pekka-acc
10) Matti syöttää Pekalla. (t3d)	Matti eat-caus-3sg Pekka-ade
11) Matti jonotuttaa Pekan uuvuksiin. (t6e)	Matti queue-caus-3sg Pekka-acc exhausted-ill
12) Matti syöttää puuron. (t3b)	Matti eat-caus-3sg porridge-acc
13) Matti jonotuttaa Pekan. (t6f)	Matti queue-caus-3sg Pekka-acc
14) Matti ompeluttaa Pekalla. (t1d)	Matti sew-caus-3sg Pekka-ade
15) Matti syöttää Pekkaa. (t3c)	Matti eat-caus-3sg Pekka-part
16) Matti jonotuttaa Pekalla. (t6d)	Matti queue-caus-3sg Pekka-ade
17) Matti ompeluttaa Pekkaa. (t1c)	Matti sew-caus-3sg Pekka-part
18) Matti syöttää Pekan kylläiseksi. (t3e)	Matti eat-caus-3sg Pekka-acc full-tra

For a better understanding of the test settings, the test is given in (2). I have translated the instructions from Finnish to English and also provide English glosses in connection to each sentence (the test itself does not include these). The numbering of the test sentences corresponds to that in (1). The original test form can be found in Appendix 1.

## (2) Language instinct test

Miten luontevilta seuraavat lauseet mielestäsi tuntuvat? Merkitse rasti asteikkoon tuntemuksesi mukaan sopivaan kohtaan (0 = täysin mahdoton; 10 = täysin luonteva). Kirjoita sama asia toisin sanoin lauseen alla olevalle viivalle. Silloinkin, kun lause on outo, sano, miten tulkitisit sen. Sano myös, jos et ymmärrä lausetta lainkaan. Kiitos avusta!

‘How natural do the following sentences sound to you? Mark a cross according to your impression at an appropriate point on the scale (0 = completely unnatural; 10 = completely natural). Rewrite the sentence using different words on the line under the sentence. Even if the sentence seems odd, say how you would interpret it. If you do not understand the sentence at all, please also note this. Thank you for your time!’

- |  |                |
|--|----------------|
| 1) Matti ompeluttaa Pekalla puvun/pukua.<br>Matti sew-caus-3sg Pekka-ade dress-acc/-part | 0   .....   10 |
| 2) Matti jonotuttaa Pekkaa.<br>Matti queue-caus-3sg Pekka-part                           | 0   .....   10 |
| 3) Matti ompeluttaa Pekan komeaksi.<br>Matti sew-caus-3sg Pekka-acc handsome-tra         | 0   .....   10 |
| 4) Matti syötättää Pekan.<br>Matti eat-caus-3sg Pekka-acc                                | .....   10     |
| 5) Matti jonotuttaa tunnin.<br>Matti queue-caus-3sg hour-acc                             | 0   .....   10 |
| 6) Matti syötättää Pekalla puuron.<br>Matti eat-caus-3sg Pekka-ade porridge-acc          | 0   .....   10 |
| 7) Matti ompeluttaa puvun.<br>Matti sew-caus-3sg dress-acc                               | 0   .....   10 |
| 8) Matti jonotuttaa Pekalla tunnin.<br>Matti queue-caus-3sg Pekka-ade hour-acc           | 0   .....   10 |
| 9) Matti ompeluttaa Pekan.<br>Matti sew-caus-3sg Pekka-acc                               | 0   .....   10 |
| 10) Matti syötättää Pekalla.<br>Matti eat-caus-3sg Pekka-ade                             | 0   .....   10 |
| 11) Matti jonotuttaa Pekan uuvuksiin.<br>Matti queue-caus-3sg Pekka-acc exhausted-ill    | 0   .....   10 |

12) Matti syötättää puuron. Matti eat-caus-3sg porridge-acc	0   .....   10
13) Matti jonotuttaa Pekan. Matti queue-caus-3sg Pekka-acc	0   .....   10
14) Matti ompeluttaa Pekalla. Matti sew-caus-3sg Pekka-ade	0   .....   10
15) Matti syötättää Pekkaa. Matti eat-caus-3sg Pekka-part	0   .....   10
16) Matti jonotuttaa Pekalla. Matti queue-caus-3sg Pekka-ade	0   .....   10
17) Matti ompeluttaa Pekkaa. Matti sew-caus-3sg Pekka-part	0   .....   10
18) Matti syötättää Pekan kylläiseksi. Matti eat-caus-3sg Pekka-acc full-tra	0   .....   10

The test was carried out on 24 April 2008 and involved 20 people with Finnish as their native tongue. The test subjects were students of Finnish at the Open University of the University of Turku. Their ages ranged from 20 to 65, and the majority were women (only one man). The educational background of the test subjects can thus be said to be academic, though not necessarily within linguistics. The majority came from the southwest region of Finland, with only one person from central Finland (Keuruu/Savo) and one from eastern Finland (Karjala). One test subject was Finnish-Swedish bilingual. The test was carried out in a classroom setting. The average time taken to answer the questions was 15 minutes.

I will begin my study of the results using two types of values: the average value (Av) of the acceptability assessments and the standard deviation (SD) value given to the tested sentences. Table (1) presents the total sum of points, the average value and the standard deviation value of each tested sentence:

Table 1. Total results, average values and standard deviation values of test sentences

Sen. no.	1	2	3	4	5	6	7	8	9	12
Total	162	85	41	97	36	105	181	40	33	103
Av.	8.1	4.3	2.1	4.9	1.8	5.3	9.1	2	1.7	5.2
SD	2.2	2.9	2.6	3.1	2.2	3.5	1.2	1.9	2.2	2.9

Sen. no.	10	11	13	14	15	16	17	18
Total	31	122	40	77	96	45	65	112
Av.	1.6	6.1	2	4.1	4.8	2.3	3.3	5.6
SD	1.5	3.4	2.2	3.4	2.8	2.3	3.3	3.0

In order to visualise the estimation of the test sentences, I present the average and standard deviation values in diagrams. Figure 1 solely presents the results of acceptability on the evaluation scale on average. Figure 2 shows the standard deviation results respectively. Comparing these two tables, we can see that language users are most united in their assessment of the extremes – the least acceptable sentence (sentence 10) and the most acceptable sentence (7) have the lowest deviation values.

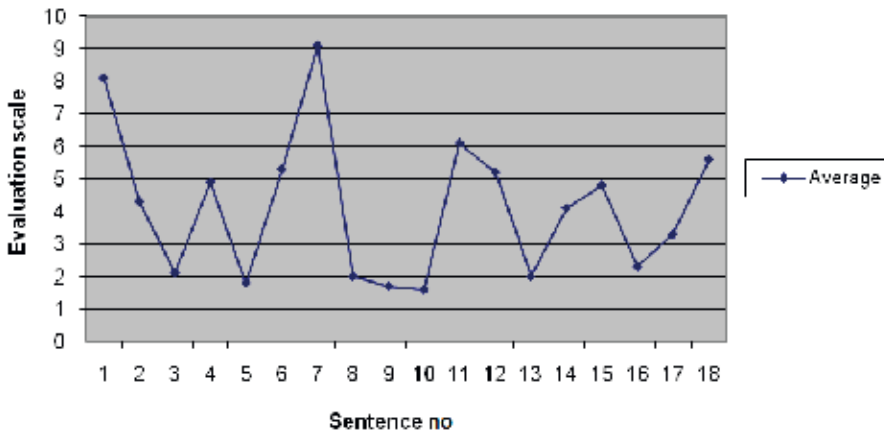

Figure 1. Average acceptability values of test sentences

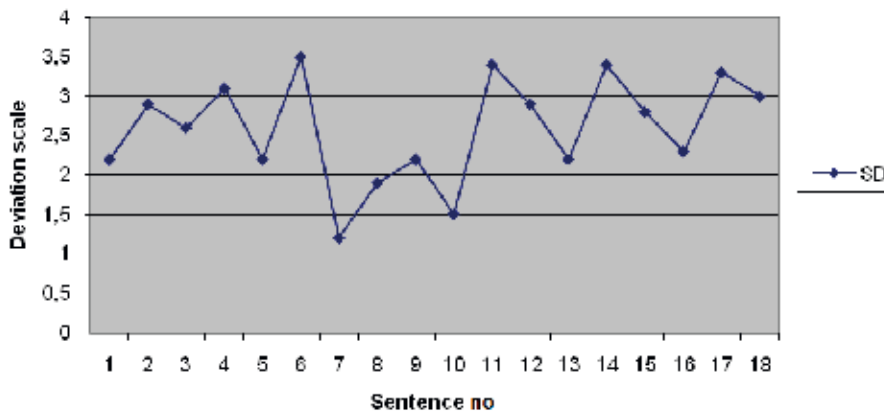

Figure 2. Standard deviation values of test sentences

However, the estimation of sentences is only one side of the study; the inferences made on the basis of the sentences are expressed by the language users' own paraphrasing. Their rewording reflects how they interpreted the sentences and how they construe the argument structure of the tested verbs. For instance, the first tested sentence *Matti ompeluttaa Pekalla puvun* is paraphrased five times using the CSD predicate *teettää* 'do-cause' (an example would be *Matti teettää Pekalla puvun* (test person (hereafter abbreviated as TP) 5) 'Matti makes Pekka do the dress') and once even with the verb *teetättää* 'do-cause-cause' with an additional *ttA*-suffix used instead of *ompeluttaa*. The root verb *ommella* 'to sew' (*Pekka ompelee Matille puvun* (TP1) 'Pekka sews the dress for Matti') is used seven times. Generally, the test subjects applied the periphrastic causative construction in their paraphrases i.e. a causative auxiliary verb and the root verb of the CSD in the first or third infinitive form (for instance *pyytää ompelemaan* 'ask s.o. to sew' or *panna ompelemaan* 'set s.o. sewing'). The other auxiliaries used in the test included *laittaa* 'to make, set', *pistaa* 'to put, set',  *antaa* 'to let', *käskää* 'to order', *vaatia* 'to demand' and even *pakottaa* 'to force'.

The use of different periphrastic constructions as well as the variation in the predicates hints at the underlying modal accent, but the relevant aspect for the present purposes is that they reflect the CSD argument structure the test subjects had in mind. In the following next sections, I discuss the sentences in relation to their responses individually by each tested verb.

#### 3.1.4.1 Results of *ompeluttaa* 'make s.o. sew'

I will start analysing the test responses with the high transitivity verb *ompeluttaa* 'make s.o. sew'. Concentrating on the assessment of *ompeluttaa* in general, we can conclude that the sentences with this verb display a considerable variation in their assessments, representing the absolute highest and near lowest values on the average acceptability scale (consider the results of the sentences with *ompeluttaa* in Table 2). Two of the sentences, (7) and (1), are ranked highest on the acceptability scale of the whole test, with values over 8. These correspond to the structures [SAD, OARobj, SARade] and [SAD, OARobj] i.e. the a- and b-sentences that were also classified as clear in connection with this verb in the syntactic test. In contrast, sentences (9) and (3) received very low acceptability values, under 3; these are the structures [SAD, SARacc] and [SAD, SARacc, RESADJtra]. Hence, the telic SAR in the position of the resultative object or the total object seems to be problematic with this verb. Comparison of the total object SAR sentence (9) to the partial (atelic) object SAR sentence (17) reveals that the latter receives stronger approval (the results being 1.7 and 3.3 respectively). An unanticipated result in the syntactic test was sentence (14) with the SAR in the adessive case and the absent OAR [SAD, SARade]: this sentence was ranked surprisingly highly – 4.1 points on average.



Table 2. Average score and standard deviation of sentences with *ompeluttaa* ‘make s.o. sew’

Test sentence	Morphological from	Av.	SD
1. <i>Matti ompeluttaa Pekalla puvun</i>	Matti sew-caus-3sg Pekka-ade dress-acc/-part	8.1	2.2
3. <i>Matti ompeluttaa Pekan komeaksi</i>	Matti sew-caus-3sg Pekka-acc handsome-tra	2.1	2.6
7. <i>Matti ompeluttaa puvun</i>	Matti sew-caus-3sg dress-acc	9.1	1.2
9. <i>Matti ompeluttaa Pekan</i>	Matti sew-caus-3sg Pekka-acc	1.7	2.2
14. <i>Matti ompeluttaa Pekalla</i>	Matti sew-caus-3sg Pekka-ade	4.1	3.4
17. <i>Matti ompeluttaa Pekkaa</i>	Matti sew-caus-3sg Pekka-part	3.3	3.3

A closer look at the paraphrasing indicates that the interpretation of ‘Pekka’ played a crucial role in how the participants construed the argument structure of the sentences – this participant was not necessarily given the status of the actor-SAR as was presupposed in the syntactic test. Therefore, I have separated the interpretations of Pekka by each *ompeluttaa* sentence; the results of this analysis are given in Table 3. The results are divided roughly in two, depending on whether Pekka is expressed as the actor-SAR. The cases where Pekka is interpreted as a role other than the SAR are given in parentheses after their number of occurrence. These roles in the *ompeluttaa* sentences are the OAR (25 cases), receiver (16 cases) and locative (1 case). The abbreviation DNU stands for ‘do not understand’; sometimes there was no response at all (marked as ‘Empty’).

Table 3. The verb *ompeluttaa* ‘make s.o. sew’ and interpretation of ‘Pekka’

	<i>Pekka</i> = SAR	<i>Pekka</i> ≠ SAR	DNU	Empty
1. <i>Matti ompeluttaa Pekalla puvun</i>	19	–	–	1
3. <i>Matti ompeluttaa Pekan komeaksi</i>	1	14 (Receiver), 3 (OAR)	1	1
7. <i>Matti ompeluttaa puvun</i>	‘Pekka’ not expressed			
9. <i>Matti ompeluttaa Pekan</i>	–	15 (OAR), 2 (Receiver)	2	1
14. <i>Matti ompeluttaa Pekalla</i>	15	1 (Locative)	2	2
17. <i>Matti ompeluttaa Pekkaa</i>	11	7 (OAR)	1	1

### ***Matti ompeluttaa puvun* (7)**

Note that sentence (7) of the structure [SAD, OARobj] is not analysed in Table 3; since it does not include the SAR (‘Pekka’), it does not fall into the categories of this categorization. In regard to the response to this sentence, it

can be said that it received the highest acceptability result: 9.1 points (see Table 2). In the rewordings, the implicit SAR is expressed as *toinen* ‘other’, *joku* ‘somebody’ or *ompelija* ‘the sewer’. The place where the dress is sewn is also expressed, for instance:

- (1) *Matti teettää ompelimosssa puvun* (TP18)  
 ‘Matti has the dress made [do-cause-3sg] at a dressmaker’s shop.’

***Matti ompeluttaa Pekalla puvun* (1)**

***Matti ompeluttaa Pekan* (9)**

As Table 3 shows, the responses to the sentences vary in their interpretation of ‘Pekka’. In sentence (1) with the structure [SAD, OARobj, SARade], Pekka is unanimously understood as the sewer, the SAR. One sentence in turn has no responses with Pekka as the SAR – sentence (9), with the structure [SAD, SARacc]. When Pekka is interpreted as the OAR, the test subjects gave additional contextual information: Pekka was having something sewn during plastic surgery, or was thought to be an inanimate entity (a doll or teddy bear), or was somehow being fastened to something. The latter interpretation is exemplified in (2a-b), the responses to sentences (9) and (17) respectively:

- (2a) *Matti ompeluttaa Pekan kiinni johonkin* (TP17)  
 ‘Matti makes s.o. sew [sew-cause-3sg] Pekka to something.’
- (2b) *Joku on ompelemassa Pekan johonkin Matin pyynnöstä* (TP17)  
 ‘S.o. is sewing Pekka onto something at Matti’s request.’

***Matti ompeluttaa Pekalla* (14)**

Most interpretations (15 in total) of sentence (14) express Pekka as the actor or the SAR in the generic meaning (‘Matti (always) has Pekka sew his clothes’). This sentence received relatively high acceptability results: 4.1 on average. One response suggests that Pekka in the adessive case represents the location in which the activity is taking place:

- (3) *Matti teettää ompelutöitä Pekan luona* (TP4)  
 ‘Matti does [do-cause-3sg] sewing at Pekka’s place.’

***Matti ompeluttaa Pekan komeaksi* (3)**

***Matti ompeluttaa Pekan* (9)**

These two sentences had the lowest acceptability values among the responses to the sentences with *ompeuttaa* ‘make s.o. sew’ (2.1 and 1.7 respectively). In 14 responses to sentence (3) and two responses to sentence (9), Pekka was comprehended as the receiver of the object of the sewing (the

explicitly mentioned objects being a dress, trousers, new clothes and the garment being sewn). Example (4) paraphrases sentence (9).

(4) *Matti ompeluttaa Pekalle housut* (TP18)

‘Matti makes s.o. sew [sew-cause-3sg] trousers for Pekka.’

Most respondents did not interpret Pekka as the SAR in resultative construction (3) but as the receiver of the clothes. A variation of this type of paraphrasing is presented in (5a). In three cases, Pekka was understood to be the object of the sewing, the OAR, as in paraphrase (5b). Here it is not clear whether the sewer is Matti or if an intermediate implicit actor is implied. The only interpretation of Pekka as the SAR shows that this reading is possible. I present this paraphrase in (5c); note that Pekka is simultaneously also understood as the receiver of the clothes.

(5a) *Matti teettää vaatteet, joilla Pekasta tulee komea* (TP4)

‘Matti has s.o. make [do-cause-3sg] clothes that make Pekka look handsome.’

(5b) *Matti tekee Pekalle kauneusleikkauksen, jonka avulla Pekasta tulee komea* (TP6)

‘Matti does [do-3sg] plastic surgery on Pekka which makes Pekka look handsome.’

(5c) *Matti teettää Pekalla puvun, jotta tämä olisi komea* (TP17)

‘Matti has Pekka make [do-cause-3sg] a dress so that he (Pekka) will look handsome.’

***Matti ompeluttaa Pekkaa* (17)**

***Matti ompeluttaa Pekan* (9)**

A remarkable effect of the object case alternation of the SAR on the argument structure appears in comparing sentences (9) and (17). Whereas the atelic SAR object structure [SAD, SARpart] is interpreted according to the original argument structure (Pekka as the SAR) in eleven responses, in the telic [SAD, SARacc] structure, Pekka is not understood to be the SAR at all. The test subjects seemed to need more contextual explanation in order to approve the telic SAR structure (9). I illustrate this with the rewordings of sentence (9) *Matti ompeluttaa Pekan* in (6a-c); Pekka here is interpreted as the OAR. However, the same people approved the SAR-Pekka in the form of the partitive object in sentence (17) *Matti ompeluttaa Pekkaa* without any hesitation, as the paraphrases in (7a-c) show.

- (6a) *Pekka-niminen nalle on mennyt rikki. Matti vie Pekan ompelijalle, joka korjaa sen.* (TP11)  
 ‘A teddy bear called Pekka has fallen apart. Matti takes it to a seamstress, who repairs it.’
- (6b) *Matti tekee Pekalle kauneusleikkauksen* (TP6)  
 ‘Matti does plastic surgery on Pekka.’
- (6c) *Pekka joutuu ommeltavaksi Mattin toimesta.* (TP4)  
 ‘Pekka ends up being sewn by Matti.’
- (7a) *Matti teettää Pekalla ompelutöitä.* (TP11)  
 ‘Matti makes Pekka do [do-cause] the sewing.’
- (7b) *Matti pistää Pekan ompelemaan.* (TP6)  
 ‘Matti sets Pekka sewing.’
- (7c) *Pekka ompelee Matille jotain.* (TP4)  
 ‘Pekka sews something for Matti.’

The object case of the SAR affects the argument structure interpretation of *ompeuttaa*; Pekka is interpreted as the patient (the OAR) when expressed as the accusative object and as the actor (the SAR) when expressed as the partitive object. Note that the semantics of the verb *ompeuttaa* in the structure [SAD, SARpart] obtains a nuance of the continuative, and the sentence can thus be understood generically. The significant outcome of this phenomenon is that high transitivity CSDs also allow the actor-SAR to occur in the partitive case; the conclusion drawn from the syntactic test in the previous section is thus not completely confirmed by the acceptability test.

An exception in respect to the other responses is the reasoning of the test subject (TP15) who treated the CSD *ompeuttaa* in sentences (9) and (17) as an underived verb (*Matti ompelee Pekkaa* ‘Matti sews Pekka’). It is possible that in this person’s idiolect the derived causative is equal to the root verb.

### 3.1.4.2 Results of *syötättää* ‘make s.o. eat’

The average outcome of the tested sentences with the second test verb *syötättää* ‘make s.o. eat’ is distinctively the most stable, with five values in middle area positioning from 4.8-5.3. Thus, the sentential alternations with this verb seem to be the most acceptable of the three tested verbs. The test sentences and their average and standard deviation results are presented in Table 4:

Table 4. Average score and standard deviation results of sentences with *syötättää* ‘make s.o. eat’

Test sentence	Morphological from	Av.	SD
4. <i>Matti syötättää Pekan</i>	Matti eat-caus-3sg Pekka-acc	4.9	3.1
6. <i>Matti syötättää Pekalla puuron</i>	Matti eat-caus-3sg Pekka-ade porridge-acc	5.3	3.5
10. <i>Matti syötättää Pekalla</i>	Matti eat-caus-3sg Pekka-ade	1.6	1.5
12. <i>Matti syötättää puuron</i>	Matti eat-caus-3sg porridge-acc	5.2	2.9
15. <i>Matti syötättää Pekkaa</i>	Matti eat-caus-3sg Pekka-part	4.8	2.8
18. <i>Matti syötättää Pekan kylläiseksi</i>	Matti eat-caus-3sg Pekka-acc full-tra	5.6	3

The rewordings of *syötättää* also reveal that this verb has a particularly flexible argument structure. In respect to the number of potential actors participating in the causation chain, a source of ambiguity is the double causative morpheme combination *ttA-ttA* in *syö-tä-ttää*. The differences in interpretations are reflected in the interpretation of ‘Pekka’. For a clearer distinction of the roles of ‘Pekka’, the SAR should be broken down to the subroles: **SAR1** for the eater of the food (the subject argument of *syödä* ‘to eat’) and **SAR2** for the feeder of the eater (subject argument of *syöttää* ‘make s.o. eat, feed’). Other roles ‘Pekka’ appears in are the implicit theme or OAR (the food), the instrumental and the locative and even the SAD.

Table 5 presents the argument places of ‘Pekka’ in respect to the *syötättää* sentences. I have marked sentence (4) in Table 5 with an asterisk (\*) because in paraphrase (3b) the test subject gave two possible interpretations of the sentence: the implicit actor was included in the argument structure, but the writer wavered between the interpretations of ‘Pekka’ as SAR1 or OAR (the food). I have counted this answer as an interpretation of Pekka as the OAR in Table 5.

Table 5. The verb *syötättää* ‘make s.o. eat’ and interpretation of ‘Pekka’

	<i>Pekka</i> = SAR2	<i>Pekka</i> ≠ SAR2	DNU	Empty
4. <i>Matti syötättää Pekan*</i>	–	19 (SAR1) 1 (OAR)	–	1
6. <i>Matti syötättää Pekalla puuron</i>	2	17 (SAR1) 1 (Instrumental)	–	
10. <i>Matti syötättää Pekalla</i>	5	7 (SAR1) 1 (SAD) 1 (Instrumental) 1 (Locative) 1 (OAR)	3	1
12. <i>Matti syötättää puuron</i>	‘Pekka’ not expressed			
15. <i>Matti syötättää Pekkaa</i>	–	20 (SAR1)	2	2
18. <i>Matti syötättää Pekan kylläiseksi</i>	–	19 (SAR1) 1 (SAD)	1	1

What do the argument structure variations tell us about the argument structure of *syötättää*? I will begin closer analysis with sentence (4):

#### ***Matti syötättää Pekan* (4)**

Test sentence (4), representing the structure [SAD, SARacc], received 4.9 points on average. The paraphrasing of this sentence indicated that the test subjects were mostly in agreement about its argument structure. A total of 19 responses interpreted Pekka as the eater or SAR1 (there was one person who gave two alternatives for this sentence: see example (34b)). As many as 15 test subjects expressed that there was an additional actor who actually fed Pekka, as in rewordings (1a-c). The contexts thought to be most likely were a situation in which Pekka was a child and the intermediate actor was a nanny, or a situation where Pekka was a patient and a nurse was feeding him (see (1b) and (1c)).

(1a) *Matti käskee jonkun toisen syöttää Pekan* (TP7)

‘Matti orders s.o. else to feed [eat-cause-inf] Pekka.’

(1b) *Matti laittoi lastenhoitajan syöttämään Pekan* (TP18)

‘Matti had the nanny feed [eat-cause-3.inf-ill] Pekka.’

(1c) *Matti pyytää (hoitajan) syöttämään Pekan* (TP13)

‘Matti asks (the nurse) to feed [eat-cause-3.inf-ill] Pekka.’

However, the argument structure of the CSD of sentence (4) can be reduced to the root verb *syöttää* ‘to feed’, as in cases (2a-d). Note that Pekka is still SAR1 i.e. the eater:

- (2a) *Matti antaa Pekalle ruokaa* (TP4)  
‘Matti gives Pekka food.’
- (2b) *Matti syöttää Pekan* (TP19)  
‘Matti feeds [eat-cause-3sg] Pekka.’
- (2c) *Matti antaa Pekan syödä* (TP20)  
‘Matti lets Pekka eat.’
- (2d) *Matti syöttää Pekalle jotakin?* (TP5)  
‘Matti feeds [eat-cause-3sg] Pekka something?’

The following paraphrases in (3a-b) illustrate the hesitation the test subjects had about the argument structure of sentence (4). In (3a), the person was not sure whether there was an intermediate actor in addition to Matti (Pekka in both cases is interpreted as SAR1 or the eater).

- (3a) *Matti syöttää Pekan / Matti laittaa jonkun syöttämään Pekan?* (TP12)  
‘Matti feeds Pekka / Matti makes s.o. feed Pekka?’
- (3b) *Matti käskee jotakuta 1. antamaan Pekalle ruokaa 2. syöttämään Pekan (leijonille?)* (TP1)  
‘Matti orders s.o. 1) to give Pekka food or 2) to feed Pekka (to the lions?).’

***Matti syöttää Pekalla puuron* (6)**

Sentence (6) of the structure [SAD, OARobj, SARade] also received quite high acceptability values, of 5.3. Generally, the argument structure was understood in two ways: the SAR (Pekka) was the intermediate actor or the eater. The former is reflected in (4a-b). Most rewordings expressed the idea that Pekka was the eater, not the feeder. The writer of (5a) gave two alternative argument structures, one with an additional intermediate actor and one without. Examples (5b-c) reflect the proposition of Matti as the direct causer and Pekka as the eater. The paraphrasing of this sentence invoked a considerable number of negative connotations: Matti’s manipulation in getting Pekka to eat the porridge is seen as a use of force (see 5b) and porridge is seen as an unappetizing food (5c).

- (4a) *Matti laittaa Pekan syöttämään puuron* (TP9)  
‘Matti gets Pekka to feed [eat-cause-3.inf-ill] the porridge (to s.o).’
- (4b) *Matti pyytää Pekan syöttämään puuron esim. vanhukselle.* (TP13)  
‘Matti asks Pekka to feed [eat-cause-3.inf-ill] the porridge e.g. to an elderly person.’

- (5a) *Matti käskee a) jonkun toisen syöttämään Pekalle puuron b) Pekan syödä puuron* (TP1)  
 ‘Matti orders 1) s.o. else to feed [eat-cause-3.inf-ill] the porridge to Pekka or 2) Pekka to eat the porridge.’
- (5b) *Matti pakottaa Pekan syömään puuron* (TP4)  
 ‘Matti forces Pekka to eat the porridge.’
- (5c) *Matti laittaa Pekan syömään puuron (jota kukaan ei halua)* (TP17)  
 ‘Matti makes Pekka eat the porridge (which nobody else wants).’

***Matti syöttää Pekalla* (10)**

One *syöttää* sentence stands out in respect to the average acceptability results – sentence (10) *Matti syöttää Pekalla*. This structure [SAD, SARade] gained the lowest outcome in the whole test, with an average acceptability value of just 1.6. Also, the standard deviation value of this sentence was low (1.5), which means that the test subjects were more or less unanimous in their decision. The paraphrasing of sentence (10) reveals its ambiguity. The source of vagueness is related in particular to the interpretation of the SARade (*Pekalla*); I have separated six possible readings of it (see Table 5). Firstly, there are five rewordings from which we can infer that the writer understood Pekka to be the feeder or SAR2, not the eater. Consider paraphrases (6a-e), where (6a-b) have the argument referring to the person actually eating as open or unspecified. Interestingly, in three other cases the test subjects added an eater participant to the proposition. The new participants refer to people who would most probably need assistance in eating: *vauva* ‘baby’ in (6c), *vanhus* ‘elderly person’ in (6d) and *lapset* ‘kids’ in (6e). Note also that in (6d) and (6e) the test subjects did not change the form of the predicate verb.

- (6a) *Pekka syöttää Matin puolesta* (TP7)  
 ‘Pekka feeds [eat-cause-3sg] on behalf of Matti.’
- (6b) *Pekka syöttää jonkun Matin pyynnöstä* (TP14)  
 ‘Pekka feeds [eat-cause-3sg] s.o. at Matti’s request.’
- (6c) *Pekka syöttää Matin vauvaa* (TP18)  
 ‘Pekka feeds [eat-cause-3sg] Matti’s baby.’
- (6d) *Matti syöttää vanhuksen Pekan avulla* (TP13)  
 ‘Matti makes Pekka feed [eat-cause-cause-3sg] the old person.’
- (6e) *Matti syöttää lapset Pekalla* (TP19)  
 ‘Matti makes Pekka feed [eat-cause-cause-3sg] the kids.’

A second reading of sentence (10) indicates that the eater or SAR1 is Pekka (seven cases). The interpretation of the intermediate actor in the



proposition varies: the actual feeder is someone other than Matti ((7a-b) or Matti feeds Pekka himself (8a-b).

(7a) *Matti pyytää jotakuta syöttämään Pekalle jotain* (TP10)

‘Matti asks s.o. to feed [eat-cause-3.inf-ill] Pekka something.’

(7b) *Matti on antanut kolmannelle henkilölle tehtäväksi syöttää Pekka*  
(TP11)

‘Matti has given a third person the task of feeding [eat-cause] Pekka.’

(8a) *Matti antaa jotakin Pekalle syötäväksi* (TP16)

‘Matti gives Pekka something to eat.’

(8b) *Pekka joutuu syömään jotain Mattin tarjoamaa* (TP17)

‘Pekka has to eat something offered by Matti.’

Also, other functions of the adessive case like the expression of a locative or instrumental add an element to the ambiguity of the sentence (10). One test subject interpreted the adessive SAR (*Pekalla*) as an expression of location, meaning ‘at Pekka’s place’ i.e. not an argument of the predicate *syötättää* but an optional adjunct. Consider the rewording in (9). The paraphrase in (10) shows that it is also possible to interpret the SARade (Pekka) as the object of eating (the OAR) i.e. the implicit theme of the root verb *syödä* ‘to eat’.

(9) *Matti syöttää jotakuta Pekan luona* (TP4)

‘Matti feeds [eat-cause-3sg] s.o. at Pekka’s place.’

(10) *Matti syöttää Pekan jollekin (lause on outo)* (TP15)

‘Matti feeds [eat-cause-3sg] Pekka to s.o. (This sentence is odd.)’

One interpretation stands out in respect to the other readings, exemplifying the ambiguity of sentence (10). In (11), the test subject reversed the argument positions of the SAD and SAR so that Pekka was the feeder and Matti the person being fed. As a summation of the interpretation of sentence (10), it should be noted that two people wrote that they did not understand the sentence, two left the paraphrasing space empty (but gave the sentence 1.5 and 2.5 points) and one person simply inserted a question mark.

(11) *Pekka syöttää Mattia* (TP3)

‘Pekka feeds [eat-cause] Matti.’

### ***Matti syötättää Pekan kylläiseksi* (18)**

The resultative construction (18) received the highest acceptability values of all sentences with *syötättää*: 5.6 points. Most rewordings of the structure [SAD, SARacc, RESADJtra] reflect the argument structure, including an

intermediate actor, as in examples (12a-b). Paraphrases (13a-c) in turn illustrate interpretations with no intermediate actor implied.

- (12a) *Matti antaa jonkun syöttää Pekan kylläiseksi* (TP3)  
 ‘Matti lets s.o. feed [eat-cause] Pekka until he has had enough.’
- (12b) *Matti laittaa (pakottaa) Pekan syömään, kunnes P. on kylläinen?*  
 (TP12)  
 ‘Matti gets (forces) Pekka to eat [eat-3.inf-ill] until P. has had enough?’
- (13a) *Matti antaa Pekalle riittävästi ruokaa* (TP15)  
 ‘Matti gives Pekka enough food.’
- (13b) *Matti syöttää Pekan kylläiseksi* (TP19)  
 ‘Matti feeds [eat-cause] Pekka until he has had enough.’
- (13c) *Matti antaa Pekan syödä kylläiseksi* (TP20)  
 ‘Matti lets Pekka eat until he has had enough.’

### **Pekka as the SAD and instrumental**

I will now present the more outstanding and unusual readings of the *syöttää* sentences. First, consider the SAD interpretations of ‘Pekka’ – the example in (14a) is a response to sentence (10) and (14b) to sentence (18):

- (14a) *Pekka syöttää Mattia* (TP3)  
 ‘Pekka feeds [eat-cause-3sg] Matti.’
- (14b) *Joku ruokkii Mattin kylläiseksi, koska Pekka on käsenyt niin* (TP2)  
 ‘S.o. feeds Matti until he is full, because Pekka has ordered them to.’

The instrumental interpretations of Pekka are of sentences (6) and (10), written by the same test subject:

- (15a) *Matti käskää jonkun antaa jollekin puuron Pekalla (vrt. lusikalla)*(TP2)  
 ‘Matti tells s.o. to give the porridge to somebody with Pekka (comp. with a spoon).’
- (15b) *Matti käskää jonkun antaa jollekin ruokaa Pekalla (vrt. lusikalla)*  
 (TP2)  
 ‘Matti tells s.o. to give somebody food with Pekka (comp. with a spoon).’

Pekka is encoded as the implicit FOOD in (16a) and the location in (16b); both paraphrases are responses to sentence (10) i.e. to the sentence with Pekka in the form of the adessive case:

(16a) *Matti syöttää Pekan jollekin* (TP15)

‘Matti feeds [eat-cause] Pekka to s.o.’

(16b) *Matti syöttää jotakuta Pekan luona* (TP4)

‘Matti feeds [eat-cause-3sg] s.o. at Pekka’s place.’

***Matti syötättää puuron* (12)**

***Matti syötättää Pekkaa* (15)**

Although sentence (12) [SAD, OARobj] does not include the element Pekka, it is worth noting that this sentence was interpreted in 10 rewordings with an additional feeder or SAR2, and in 10 rewordings without an intermediate actor. Example (17a) illustrates a response that included an SAR2, and example (17b) is an example without an SAR2:

(17a) *Matti teettää puuron syöttämisen muilla* (TP7)

‘Matti has the porridge fed [eat-cause-3.inf] by other people.’

(17b) *Matti ei pidä puurosta vaan pakottaa jonkun syömään sen* (TP11)

‘Matti does not like the porridge but forces s.o. to eat it.’

Sentence (15) of the structure [SAD, SARpart] is interpreted unanimously in such a way that Pekka is the SAR1 (the eater). Interestingly, the rewordings indicate that 13 test subjects encoded this sentence including the SAR2 and seven without it. Is the double-actor reading stronger with sentence (15) compared to sentence (12), and is the SAR1 (Pekka) therefore explicit in (15)? The paraphrases in (18a-b) are examples of both cases, respectively:

(18a) *Matti teettää Pekan syöttämisen toisella henkilöllä* (TP9)

‘Matti has Pekka fed [do-cause Pekka eat-cause-3.inf] by another person.’

(18b) *Matti antaa ruokaa Pekalle* (TP15)

‘Matti gives Pekka food.’

I will summarize the reflection of the *syötättää* paraphrases with an observation on the variation in derivation forms used in the rewordings: the derivative *syötättää* is used three times, and a reduction of it, *syöttää*, 19 times. The use of *syöttää* as a substitute for *syötättää* is an interesting phenomenon from the point of view of the compositionality of causativization. Remarkably, one rewording (see 19d) is even a triple *ttA*-causative, *syötättyttää*, in response to sentence (6). Compare the variations used in the test, including the bare root verb *syödä* ‘to eat’:

- (19a) *Pekka syö Mattin puuron* (TP14)  
‘Pekka eats Matti’s porridge.’
- (19b) *Matti syöttää Pekalle puuroa* (T15)  
‘Matti makes Pekka eat [eat-cause-3sg] the porridge.’
- (19c) *Matti syöttättää Pekalle puuron* (TP19)  
‘Matti makes Pekka eat [eat-cause-cause-3sg] the porridge.’
- (19d) *Matti ei itse halua puuroa ja syötättyttää sen Pekalla?* (TP12)  
‘Matti does not want the porridge himself so makes Pekka eat [eat-cause-cause-cause-3sg] it.’

### 3.1.4.3 Results of *jonotuttaa* ‘make s.o. queue’

The third verb in the language instinct test was *jonotuttaa* ‘make s.o. queue’. The responses to the *jonotuttaa* sentences in terms of their average acceptability as well as standard deviation are presented in Table 6:

Table 6. Average score and standard deviation results of sentences with *jonotuttaa* ‘make s.o. queue’

Test sentence	Morphological from	Av.	SD
2. <i>Matti jonotuttaa Pekkaa</i>	Matti queue-caus-3sg Pekka-part	4.3	2.9
5. <i>Matti jonotuttaa tunnin</i>	Matti queue-caus-3sg hour-acc	1.8	2.2
8. <i>Matti jonotuttaa Pekalla tunnin</i>	Matti queue-caus-3sg Pekka-ade hour-acc	2	1.9
11. <i>Matti jonotuttaa Pekan uuvuksiin</i>	Matti queue-caus-3sg Pekka-acc exhausted-ill	6.1	3.4
13. <i>Matti jonotuttaa Pekan</i>	Matti queue-caus-3sg Pekka-acc	2	2.2
16. <i>Matti jonotuttaa Pekalla</i>	Matti queue-caus-3sg Pekka-ade	2.3	2.3

In *jonotuttaa* paraphrases also, the construal of the element ‘Pekka’ shows some discrepancy. In addition to the actor-SAR, it is interpreted as locative or instrumental. The interpretations of Pekka in the rewordings are presented in Table 7. Sentence (16) is marked with an asterisk (\*) because there are two ambiguous rewordings given for it: it is not possible to infer whether the writer means that *Pekalla* is a locative or the SAR (or even an instrumental?). Therefore, I have not included these cases in the results in Table 7.

Table 7. The verb *jonotuttaa* ‘make s.o. queue’ and interpretation of ‘Pekka’

	Pekka = SAR	Pekka ≠ SAR	DNU	Empty
2. <i>Matti jonotuttaa Pekkaa</i>	20	–	–	–
5. <i>Matti jonotuttaa tunnin</i>	SAR implicit			
8. <i>Matti jonotuttaa Pekalla tunnin</i>	10 1 (with SAD)	5 (Locative) 1 (Instr.)	2	1
11. <i>Matti jonotuttaa Pekan uuvuksiin</i>	19	–	–	1
13. <i>Matti jonotuttaa Pekan</i>	14 1 (SAR1)	–	4	1
16. <i>Matti jonotuttaa Pekalla*</i>	7	3 (Locative) 2 (Instr.)	4	1

***Matti jonotuttaa Pekalla tunnin (8)******Matti jonotuttaa Pekalla (16)***

It is noticeable that there are two sentences given other interpretations of Pekka in addition to the SAR: (8) and (16). Both are structures with Pekka in the adessive case i.e. [SAD, OARobj, SARade] and [SAD, SARade]. Half of the test subjects interpreted Pekka in sentence (8) as the SAR, the actor. In one person’s paraphrasing, the SAD and SAR perform the queuing activity together; see example (1a). The instrumental reading of Pekka is given in (1b). There are a total of five locative interpretations of Pekka among the responses to sentence (8); consider two of them in (1c-d):

(1a) *Matti ja Pekka jonottavat tunnin (TP19)*

‘Matti and Pekka queue [queue-3pl] for an hour.’

(1b) *Matin ansiosta muut joutuvat jonottamaan Pekan takia tunnin (TP16)*

‘Thanks to Matti, others end up queuing [queue-3.inf-ill] for an hour because of Pekka.’

(1c) *Matti jonottaa Pekalla (=joku paikka) tunnin? (TP12)*

‘Matti queues [queue-3sg] at Pekka’s (=some place) for an hour?’

(1d) *Matti on käskenyt jonkun (puuttuu lauseesta) olla jonossa Pekan luona tunnin ajan (TP2)*

‘Matti has told s.o. (not in the sentence) to stand in the queue at Pekka’s for an hour.’

Sentence (16) received an average acceptability result of just 2.3. Four test subjects in total responded that they did not understand the sentence, and one did not respond at all. There were seven interpretations of Pekka as SAR1 i.e. the situation was understood to mean that Matti caused Pekka to be standing in the queue. The examples in (2a-c) show the possible contexts of the

queuing situation the respondents gave; the queue may have formed in the Soviet Union, at a ticket window or simply outside a door. Examples (2d-e) indicate that Pekka is queuing on behalf of Matti. Notice the periphrastic causative construction *antaa jonotuttaa* in (2e) – the infinitive verb remains the causative derivative, although the respondent most likely does not mean that there is an additional actor in the situation.

- (2a) *Matti käskee Pekan jonottaa (esim. Neuvostoliitossahan tätä tehtiin)*  
(TP1)  
‘Matti orders Pekka to queue (for instance in the Soviet Union, where this was common).’
- (2b) *Matti pyysi Pekkaa jonottamaan puolestaan lippuluukulle* (TP18)  
‘Matti asked Pekka to queue on his behalf at the ticket window.’
- (2c) *Matti pitää Pekkaa jonossa jotta oven taakse tulee edes 1 hlön jono*  
(TP11)  
‘Matti keeps Pekka in the queue so that there is at least 1 person in the queue outside the door.’
- (2d) *Pekka jonottaa Mattin puolesta* (TP7)  
‘Pekka queues on behalf of Matti.’
- (2e) *Matti antaa Pekan jonotuttaa puolestaan* (TP3)  
‘Matti lets Pekka queue [queue-cause-inf] on his behalf.’

Two test subjects decoded Pekka as the reason for the implicit others’ queuing, whereas Matti, the SAD, was using Pekka as the instrument (possibly as an excuse for having to queue). The instrumental readings of Pekka are presented in (3b-c):

- (3b) *Matti antaa muiden jonottaa Pekan takia* (TP16)  
‘Matti lets others queue because of Pekka.’
- (3c) *Matti pistää muut jonottamaan Pekan takia* (TP6)  
‘Matti has others queue because of Pekka.’

The expected argument structure is not fully realized in the following examples either. The adessive SAR *Pekalla* is inferred as the locative adverbial ‘at Pekka’s’ in three rewordings, not as the SAR. Examples of such interpretations are presented in (4a-c); note that in (4a-b) the actual person in the queue is expressed by *joku* ‘someone’ and Matti is the indirect causer, whereas in (4c) the person in the queue is the SAD (Matti). Note that the predicate (*jonotuttaa*) remains the same in sentence (4b) as in the source sentence (16).

(4a) *Matti on käsenyt jonkun jonoon Pekan luokse* (TP2)

‘Matti has ordered s.o. to queue at/for Pekka’s place.’

(4b) *Matti jonottaa jotakuta Pekan luona* (TP14)

‘Matti makes s.o. queue [queue-cause-3sg] at Pekka’s place.’

(4c) *Matti jonottaa Pekan luona/luokse?* (TP12)

‘Matti queues [queue-3sg] at/for Pekka’s place?’

Note that there is an additional performer (*joku* ‘someone’ and *ihmiset* ‘people’) with the root verb activity in both cases. Consider the paraphrasing in (5a-b):

(5a) *Matti pyytää jotakuta jonottamaan Pekalla* (TP10)

‘Matti asks s.o. queue [queue-3.inf-ill] at Pekka’s [Pekka-ade].’

(5b) *Matti jonottaa ihmisiä Pekalla* (TP15)

‘Matti makes people queue [queue-cause-3sg] at Pekka’s [Pekka-ade].’

Hence language users generally do not approve of the agent reading for the SARade with *jonottaa* in sentence (16), *Matti jonottaa Pekalla*. The relation between assessments and rewordings strengthens this conclusion: there is a tendency for test subjects who interpret Pekka as the SAR not to consider this sentence as a good one, while those who understand Pekka to be part of the locative expression i.e. an optional adjunct estimate its acceptability more highly.

### ***Matti jonottaa Pekkaa* (2)**

In contrast to the SARade structures of *ompeuttaa*, the sentences with Pekka in object cases are comprehended without exception in such a way that Pekka is the SAR. Of the sentences with the SAR in the object position, the partitive SAR in sentence (2) of the structure [SAD, SARpart] is accepted relatively widely, with a result of 4.3 on average. The contextual backgrounds developed by the respondents reflect a situation where Matti is somehow in the lead, like the doorkeeper situation in (6a). Also, the paraphrasing including causative constructions with *pitää* ‘to keep’ and *antaa* ‘to let’, lending this kind of impression (see (6b-c)). The auxiliary verb *joutua* ‘to end up; have to’ in turn emphasizes the inevitability and uncongeniality of queuing from Pekka’s perspective (see 6d).

(6a) *Matti on esim. portsari ja pitää Pekkaa jonossa oven takana päästäen muut ohi* (TP11)

‘Matti is for instance a bouncer and keeps Pekka in the queue outside the door while letting others in.’

(6b) *Matti pitää Pekan odottamassa (TP5)/ jonossa (TP14)*

‘Matti keeps Pekka waiting/in the queue.’

(6c) *Matti antaa Pekan jonottaa (TP3)*

‘Matti lets Pekka queue.’

(6d) *Pekka joutuu jonottamaan Mattin takia (TP4)*

‘Pekka ends up queueing because of Matti.’

***Matti jonotuttaa Pekan (13)***

Compared to the partitive SAR structure, sentence (13), representing the structure [SAD, SARacc], receives a much lower rating, with just 2 as the average acceptability value. Four people responded that they did not understand the sentence (one explaining that the problem was due to object case error). Another person paraphrased it with the remark that the accusative case was problematic in the sentence (see (7a)). The respondents tried to find contexts for the sentence: in (7b) the background of a cash desk queue, and in (7c) a situation where Pekka is forced to stand in a queue while others are let in ahead of him. These two rewordings indicate that Pekka is not allowed to reach his goal, which is remarkable in respect of the total object telic characteristics (see 3.1.1). The temporal boundaries limiting this proposition are expressed in (7d), accentuating the achievement reading of the queuing event. The time limit has an effect on the situation, with the queuing understood to be a punishment for Pekka. There is an indication of a power relationship between Matti and Pekka where Matti has the authority and control over Pekka and his queuing.

(7a) *Matti pistää Pekan jonottamaan – akkusatiivi tuntuu mahdottomalta (TP17)*

‘Matti makes Pekka queue – the accusative seems impossible here.’

(7b) *Matin kassa ei palvele Pekkaa (TP18)*

‘Matti’s cash desk does not serve Pekka.’

(7c) *Muut pääsee ohi, Pekka vaan joutuu seisomaan jonossa (TP11)*

‘Others are let in, but Pekka has to stand in the queue.’

(7d) *Pekka on jonossa (tietyn ajan), koska Matti on käskenyt niin (TP2)*

‘Pekka waits in the queue (for a certain time) because Matti has ordered so’.

The only clearly double-causative interpretation of all *jonotuttaa* sentences encoding an additional actor argument between the SAD (Matti) and Pekka is one of the responses to sentence (13). In Table 7, this interpretation of Pekka is referred to with the exacter notation SAR1. Consider this sentence in (8):



(8) *Matti käskee jotakuta jonottamaan Pekkaa* (TP1)

‘Matti orders s.o. to make Pekka queue.’

***Matti jonotuttaa Pekan uuvuksiin* (11)**

Sentence (11), the resultative construction of *jonotuttaa* [SAD, SARacc, RESADill], is the third most approved sentence in the entire test, with an average value of 6.1. A typical response to this sentence is given in (9a), but the situation can also be understood in such a way that Matti also queues (see 9b). It is noticeable that the test subjects tended to explain the resultative event.

(9a) *Matti on käskenyt Pekan jonottamaan ja Pekka on jonottanut uupumiseen asti* (TP2)

‘Matti has ordered Pekka to queue and Pekka has queued to the point of exhaustion.’

(9b) *Matin kanssa jonottaminen saa Pekan uuvuksiin* (TP19)

‘Queuing with Matti makes Pekka exhausted.’

***Matti jonotuttaa tunnin* (5)**

In sentence (5), with the structure [SAD, OARobj], Pekka is not expressed, but the interpretation of the derivative is remarkable. The majority of responses (12) indicate an implicit actor in the proposition of (5), whereas there were four test subjects who interpreted the verb *jonotuttaa* as being equal to its root verb *jonottaa* ‘to queue’. Additionally, in three responses, both possibilities were presented. There was also one person who did not understand the sentence (but explained the problem by the lack of an object). Examples (10a-b) represent the responses with an intermediate actor and example (11) a synonymous interpretation with the root verb.

(10a) *Muut joutuvat jonottamaan tunnin Matin takia* (TP7)

‘Others end up queueing for an hour because of Matti.’

(10b) *Matti on esim. portsari ja avaa ravintolan oven vasta tunnin päästä aukeamis-ajankohdasta* (TP11)

‘Matti is for instance a bouncer and does not open the restaurant door until an hour after opening time.’

(11) *Matti jonottaa tunnin* (TP6)

‘Matti queues for an hour.’

In general, the responses to the verb *jonotuttaa* ‘make s.o. queue’ show, in certain aspects, a different pattern than the other tested verbs (*ompeuttaa* ‘make s.o. sew’ and *syötättää* ‘make s.o. eat’). The structures that received high acceptability results with *ompeuttaa* and *syötättää*, [SAD, OARobj,

SARade] and [SAD, OARobj], were more lowly ranked by the test subjects in connection with *jonotuttaa*. The sentences corresponding to the mentioned structures are (5) and (8), with 1.8 and 2 points on average respectively. The explanation for these results seems to be that a situation where Pekka has to stand in a queue requires clarification of the reason. The temporal expression as an adverbial of amount in the object case *tunnin* ‘for an hour’ seems not to be sufficient in this respect; an OAR, a more prototypical object, is required. The responses to sentences (5) and (8), respectively, illustrate the need for an explanation:

(12a) *Matti käskee muita jonottamaan, mutta mitä?* (TP1)

‘Matti orders others to queue, but for what?’

(12b) *Matti käskee Pekan jonottamaan tunnin ajan (mutta mitä?)* (TP1)

‘Matti orders Pekka to queue for an hour (but for what?).’

However, there is also a parallel between the high transitivity verb *ompeuttaa* and the low transitivity verb *jonotuttaa* in that they obtain low average rating for the structure [SAD, SARacc], whereas the middle transitivity CSD *syötäyttää* receives quite a high result for this structure. As a final remark on the rewordings with *jonotuttaa*, we can ask about the nature of causation in the constructions with *joutua* ‘to end up with, run into’, *antaa* ‘to let’ and *pitää jonossa/odottamassa* ‘to keep in a queue/waiting’. Is the expressed situation causative or permissive? The SAD in these cases is given the power to prevent the activity of the SAR, but does not do so.

#### 3.1.4.4 Language instinct test summarized

After the verb-specific analysis of the test results above, I will return to the overall perspective of the test. The central questions in this section are: how do the tested verbs adapt the alternations of sentence structure? Do the language instinct test results correlate with the assessments of the sentences made in the syntactic test in section 3.1.3? What does the language instinct test reveal about the acceptability respective comprehension of the sentences? What are the benefits and weaknesses of this type of test and how can it be improved? To begin, let us look at an overview of the acceptance of the argument structures by tested CSD. Table 8 presents the average acceptability results in terms of the the argument structures for each verb. I have marked the results on the structures that received mainly different interpretations of ‘Pekka’ than the active SAR in bold typeface (compare also with the verb-specific tables 3, 5 and 7 in sections 3.1.4.1-3.1.4.3).

Table 8. Sentence structures and average acceptability results of tested verbs

	<i>ompeuttaa</i> 'make s.o. sew'	<i>syöttää</i> 'make s.o. eat'	<i>jonottaa</i> 'make s.o. queue'
[SAD, OARobj, SARade]	8.1	5.3	<b>2</b>
[SAD, OARobj]	9.1	5.2	1.8
[SAD, SARpart]	<b>3.3</b>	4.8	4.3
[SAD, SARade]	4.1	<b>1.6</b>	<b>2.3</b>
[SAD, SARacc, RESADJtra/ill]	<b>2.1</b>	5.6	6.1
[SAD, SARacc]	<b>1.7</b>	4.9	2

These results show that the verbs differ quite a lot in their adaptation of argument structures. The most divergent structure is [SAD, OARobj], which received the highest result of the whole test (9.1) in connection with *ompeuttaa*, 5.2 on average with *syöttää* and just 1.8 with *jonottaa*. The structure that was given most equal points was [SAD, SARpart], with average acceptability points of 3.3, 4.8 and 4.3 for each verb respectively.

Analysis of the paraphrasing of the CSD sentences in sections 3.1.4.1-3.1.4.3 shows that the interpretation of the sentences is in some cases found outside of the expected argument structure of the CSDs. The crucial factor in argument structure construal is the interpretation of the (expected) SAR i.e. Pekka in the tested sentences. Besides the SAR, it can be interpreted as the OAR, the locative, the instrumental or the reason (because of Pekka) for the activity expressed by the root verb. A correlation can be seen between the argument structure variations and the responses with an open SAR interpretation – the sentences interpreted most frequently beyond the actor-SAR of Pekka are accepted least. In contrast, the sentences that obtained the highest acceptability values were those with no interpretations of Pekka other than as the SAR.

The verb *syöttää* stands out in the sense that it adapts the alternations of syntactic structure quite well despite the variations of interpretation of Pekka. However, the lowest accepted sentence with *syöttää* is the structure [SAD, SARade], which was also given the most Pekka interpretations other than as the SAR (both SAR1 and SAR2) in respect to other *syöttää* sentences. This sentence structure is also disapproved of and ambiguous with *jonottaa*. The element SARade seems to be the source of ambiguity when it comes to the verbs *syöttää* and *jonottaa*. I conclude that if the actor reading is not obvious and supported, for instance, by context, other functions of the adessive case are activated.

The object case alternation of the SAR is a further factor that can affect argument structure interpretation. Recall the discussion of the structures

[SAD, SARacc] and [SAD, SARpart] of *ompeluttaa* indicating that the SARpart receives a stronger actor interpretation, whereas the accusative case triggers other readings as well. In connection with *syötättää*, object case variation seems to have a merely aspectual function. The structure [SAD, SARacc] tends to be rejected in connection with *jonotuttaa*, whereas in the resultative construction, the SARacc is rated highly.

Depending on the lexical properties of the root verb, roles of Pekka than the abovementioned can also be triggered, like the receiver of the OAR in connection to *ompeluttaa* and the implicit 'food' (the OAR) in connection with *syötättää*. The appearance of Pekka in object cases or in the adessive contributes differently to interpretation by tested verb. Whereas most of the test subjects comprehended Pekka as the actor-SAR in the SARade-structures of *ompeluttaa*, the same relation holds with the sentences with Pekka in the object cases of *jonotuttaa*.

I return now to the analysis of the test results as a whole. How are the sentences ranked according to the received points? Table 9 presents the average evaluation values, standard deviation results and total points of all of the tested sentences in acceptability ranking order (to trace the actual sentences more easily, compare to (3) below). The acceptability ranking order of the tested sentences can be visualised in the form of a diagram as in Figure 3, from highest to lowest value.

Table 9. Results in acceptability order

Acceptability	Sentence no.	Average	Standard deviation	Total
1.	7	9.1	1.2	181
2.	1	8.1	2.2	162
3.	11	6.1	3.4	122
4.	18	5.6	3.0	112
5.	6	5.3	3.5	105
6.	12	5.2	2.9	103
7.	4	4.9	3.1	97
8.	15	4.8	2.8	96
9.	2	4.3	2.9	85
10.	14	4.1	3.4	77
11.	17	3.3	3.3	65
12.	16	2.3	2.3	45
13.	3	2.1	2.6	41
14.	8	2	1.9	40
15.	13	2	2.2	40
16.	5	1.8	2.2	36
17.	9	1.7	2.2	33
18.	10	1.6	1.5	31

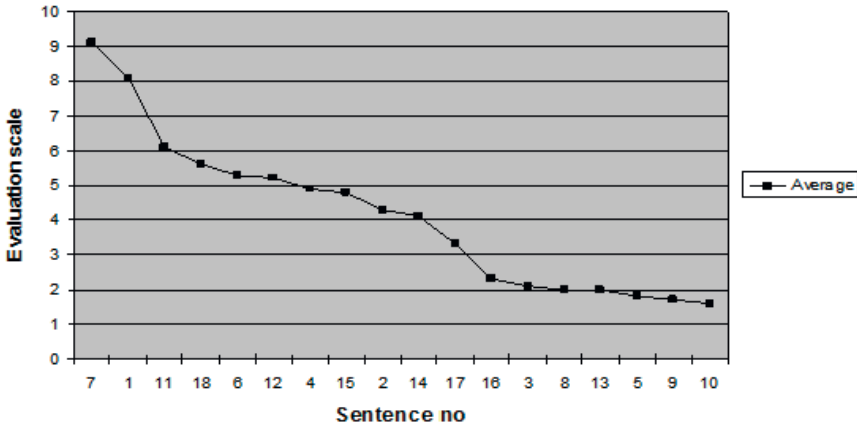

Figure 3. Average values in acceptability order

The line in Figure 3 illustrates the difference between the clear and unclear sentences quite explicitly. The acceptability values show a noticeable grouping of sentences. Firstly, there are two sentences with outstandingly high rates: sentences 7 and 1, with average values of 9.1 and 8.1 respectively. The second group comprises sentences between the values of 3 and 6 (11, 18, 6, 12, 4, 15, 2, 14 and 17 – nine sentences in total). The third group consists of seven sentences – 16, 3, 8, 13, 5, 9 and 10; these all fall below an average value of 3. The first group incorporates unquestionably clear sentences; the third group can be assessed as unclear. The sentences that fall between these extremes can thus be considered the intermediate group. I present the sentences of these three groups according to their acceptability values from higher to lower (the number in brackets standing for the sentence number) in (3). For comparison with the syntactic test classification of sentences, I mark the unclear sentences from the syntactic test with (#); as the progression of the sentences in (3) shows, the assessments quite closely match. The last two sentences in the intermediate group, (14) and (17), are classified as unclear in the syntactic test but assessed as relatively comprehensible in the language instinct test. I assume that these are borderline cases: sentences that need further supporting context in order to be accepted.

## (3) Clear and unclear sentences according to language instinct test

## I Clear sentences:

1. Matti ompeluttaa puvun (7)
2. Matti ompeluttaa Pekalla puvun/pukua (1)

## II Intermediate group:

3. Matti jonotuttaa Pekan uuvuksiin (11)
4. Matti syöttää Pekan kylläiseksi (18)
5. Matti syöttää Pekalla puuron (6)
6. Matti syöttää puuron (12)
7. Matti syöttää Pekan (4)
8. Matti syöttää Pekkaa (15)
9. Matti jonotuttaa Pekkaa (2)
10. #Matti ompeluttaa Pekalla (14)
11. #Matti ompeluttaa Pekkaa (17)

## III Unclear sentences:

12. #Matti jonotuttaa Pekalla (16)
13. #Matti ompeluttaa Pekan komeaksi (3)
14. #Matti jonotuttaa Pekalla tunnin (8)
15. #Matti jonotuttaa Pekan (13)
16. #Matti jonotuttaa tunnin (5)
17. #Matti ompeluttaa Pekan (9)
18. #Matti syöttää Pekalla (10)

Thus, based on the acceptability estimation of the test subjects, we can say that the assessment of the clear and unclear sentences in the syntactic test holds quite well. All of the group III sentences are marked as unclear, as well as sentences (14) and (17) in group II.

Surprisingly, the sentence *Matti ompeluttaa Pekkaa* (17) does not fall into the obviously unclear group according to the test subjects; it is the last sentence in the intermediate group. As discussed in connection with the paraphrasing of *ompeluttaa*, it appears that a high transitivity CSD allows the actor SAR to also occur in the partitive case. What makes this sentence ambiguous is the open interpretation of the SAR – is it the performer of the action (the SAR) or the patient or target of the action (the OAR)? By way of comparison, the sentence *Matti ompeluttaa puvun* (7), where the OAR occurs as an object with the same verb, obtained the highest results (9.1). Nevertheless, the test shows that it is **possible** to link the SAR with the object position even when the CSD is derived from a high transitive base like *ommella* ‘to sew’ even without context. This is a significant result in light of the assumption that the SAR occurs in object cases when the curative verb is derived from an intransitive root; in the case of transitive roots, the SAR is expected to occur in the adessive case (see for instance Kytömäki (1989: 62)).

In the case of *syöttää*, the SAR and OAR are almost identically accepted in the object position. Consider the sentences *Matti syöttää puuron* (12) and

*Matti syötättää Pekan* (4): the average acceptability value of these sentences is 4.8 and 4.3 respectively. This confirms the flexible argument structure of medium transitivity verbs. Another interesting result is that the *syötättää* structures with the SAR in object case alterations, [SAD, SARpart] and [SAD, SARacc], were almost equally accepted by the test subjects. The sentence of the later variant, *Matti syötättää Pekan* (4), which I expected to be an unclear sentence, is surprisingly ranked even slightly higher (with an average of 4.9) than *Matti syötättää Pekkaa* (15), which earned 4.8 acceptability points on average. In contrast, the high transitivity verb *ompeluttaa* and the low transitivity verb *jonotuttaa* differ from *syötättyttää* regarding acceptability of the last sentence type – sentences (13) and (17) are placed in the unclear sentence group (see also 3.1.4.3).

It is remarkable that the resultative constructions with *jonotuttaa* and *syötättää* receive high acceptability rates; they are ranked third and fourth. The resultative construction with *ompeluttaa* in turn received on average just 2.1 points, and is placed in the unclear sentence group. Low and medium transitivity verbs thus adapt the resultative construction with the SARobj considerably more effectively than high transitivity verbs. There is also a difference between these verbs in terms of how Pekka is interpreted in the resultative construction. With *ompeluttaa*, there is only one reading of Pekka as the SAR; in the majority of responses (14), he is interpreted as the receiver and in three cases as the OAR. Most of the responses to *syötättää* and *jonotuttaa* in the resultative construction indicated that *Pekka* was the SAR.

Another noticeable observation is that as many as five sentences with the verb *syötättää* are placed in the first part of the acceptability order i.e. these were rated relatively highly, between 4.8 and 5.6. The lowest accepted sentence of all is the 6th sentence with *syötättää*: *Matti syötättää Pekalla* (10) of the structure [SAD, SARade]. This structure is ranked more highly in connection with *jonotuttaa*, in twelfth place (the first sentence in the unclear group). The d-sentence with *ompeluttaa* is surprisingly placed in the intermediate group. In connection with *syötättää* and *jonotuttaa*, the curative sentence thus seems to behave in a similar way to the resultative construction – in order to license the SARade, there has to be an object.

Figure 4 demonstrates the standard deviation chart in order of the acceptability of the test sentences (compare to Figure 3, the average values in acceptability order). The diagram shows an interesting regularity: the sentences in the first and last group all have values under 2.6, whereas the middle group shows the highest standard deviation values, between 2.8 and 3.5. The intermediate group can be considered to comprise the most ambiguous sentences; the acceptability of these sentences depends on the imagination of language users – their ability to create suitable contexts for sentential alternations. There is thus a tendency for test subjects to be most in agreement about the clearest and unclearest sentences; the intermediate group divides opinions most.

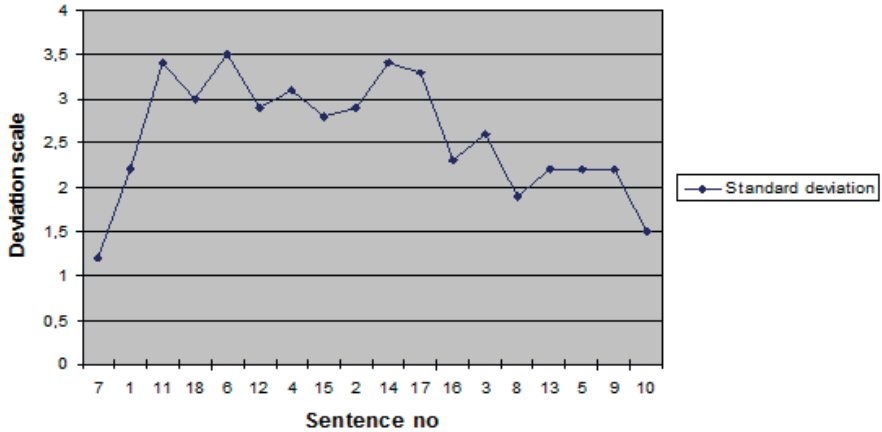

Figure 4. Standard deviation values in acceptability order

For a better understanding of the correlation between the values operating here, I have merged the lines of the average acceptability of the tested sentences in order from highest to lowest value (Figure 3) and the standard deviation values (Figure 4) in Figure 5. The dotted lines mark the grouping of the sentences (see (3)).

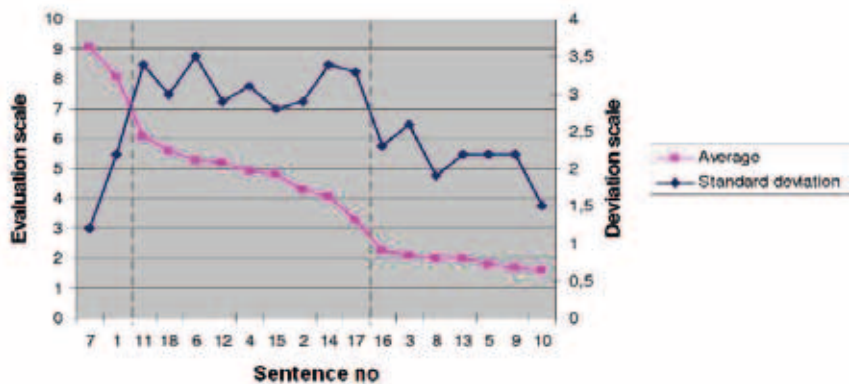

Figure 5. Average acceptability and standard deviation

Does the test estimation of sentences reflect how well the test subjects understood the sentences? An observation based on the test results is that the acceptability assessment does not directly correlate with the comprehension of the sentences. Even sentences which are not approved of are often paraphrased. Consider for instance rewording (1a) given for sentence (3)



*Matti ompeluttaa Pekan komeaksi*, marked with 0 points on the acceptability scale:

- (1a) *Matti tekee Pekalle kauneusleikkauksen, jonka avulla Pekasta tulee komea* (TP6)  
'Matti does plastic surgery on Pekka which makes Pekka look handsome.'

The ability of language users to develop a possible context for a sentence can make a generally disapproved of sentence acceptable. For instance the *jonotuttaa* sentence (16) *Matti jonotuttaa Pekalla*, with quite a low average acceptability result of 2.3, received the maximum 10 points from a test subject who associated the proposition with a concrete situation.

- (2a) *Matti käskee Pekan jonottaa* (esim. *Neuvostoliitossahan tätä tehtiin*) (TP1)  
'Matti orders Pekka to queue (for instance in the Soviet Union, where it was common).'

In my opinion, cases where the test subjects said that they did not understand a sentence should be treated with caution. The test subjects may have said 'I do not understand' but still paraphrased the sentence or pointed out that the problem lay, for instance, in the 'wrong' case. The meaning of an ungrammatical sentence can thus still be inferred if a person succeeds in identifying the argument structure. Hence, this type of language instinct test indicates that the understanding of a sentence is a more complicated issue than it seems at first. The relativity of understanding something is essentially a philosophical question. The relationship between comprehension and acceptability raises questions about language instinct and its functioning principles more broadly.

The purpose of the language instinct test as used here was to open up new perspectives on the phenomenon of CSDs and to present an in-depth description of the syntactico-lexical properties of the tested verbs. However, generalizations should be made with care; the rules of language use are marked by larger tolerance than grammatical rules alone. I am also aware of the limitations of the test as used in the study – the sentences are presented without any explicatory context and the test includes no control sentences. Nevertheless, the language instinct survey serves for the present purpose, which is to highlight the intuition of language users in a simple way. The paraphrasing explains relatively well how the argument structure of the verbs in question is understood, and the acceptability assessments hint at the grammaticality of the sentences. Thus, this test functions as support for linguistic analysis and as a complement to argumentation.

---

The test in its present form also functions well in mapping the possible contexts of a lexeme one intends to examine. Are the unclear sentences more acceptable if there is contextual support for SAR interpretation in ambiguous cases? The test could be developed further by creating larger contexts and embedding the target sentences in these contexts. One outcome of the test as carried out in this study has been that the test has the potential to be developed through more restricted or varied criteria. It generates ideas about possible directions for future investigation. The paraphrasing in particular highlights the methods of interpretation that language users use. What happens by varying the contexts systematically? Would the acceptability values rise if the context was more specific and extensive? For instance, if there were a context supplying a reason for Matti's causing Pekka to queue, would the sentences with low acceptability results receive greater approval? In what contexts are the sentences grammatical? As an option, the sentences could be presented in a constrained context, and the effect of this on the interpretations studied. Another way would be to ask the test subjects to come up with possible contexts for the sentences.

Naturally, the verb selection criteria and the sentence types could also be varied. By changing the values and form of the test, different factors would need to be controlled. For instance, by including control sentences among the target sentences, the limits of the test should be considered. I have already completed and carried out an analogous survey as a pilot test including control sentences, with the result that the test became too much for the subjects (taking, on average, 40 minutes to complete). Therefore, I arrived at a shorter version of the test. Based on my observations, the subjects remained alert throughout the test and their responses were written while in this condition.

In regard to future research, the test could also be repeated as is, in order to prove the results of the test carried out here. Would the response be similar? The sample of test subjects could be widened, and the results compared to the present ones. The repeated test could also present an opportunity to acquire a more profound understanding of the contexts in which the sentences occur. Also, the underlying modal accent expressed by the different (auxiliary) verbs used in the paraphrasing is a phenomenon worth examination. At this point, I leave closer experimental investigation of the argument structure and the effect of language instinct on *ttA*-causatives for future research.

### 3.2 Linking from LCS to syntactic arguments

The previous discussion in this chapter concerned the syntactic behaviour of CSDs from the point of view of the transitivity of root verbs. As we saw, intransitive root verbs can take a provisory object or an object-like modifier, which also function in connection with the derivative structure; this allows the use of the adessive adjunct in the CSD sentence type [SAD, OARobj, SARade]. Thus, measure phrases, cognate objects and adverbials of duration and frequency can function as objects with a generally intransitive verb and, as a result, operate like transitive verbs. On the other hand, a CSD derived from a transitive verb can correspond to the prototype 2 structure expressing the SAR in the partitive (see the discussion about *ompelettaa* ‘make s.o. sew’ in section 3.1.4.1). This shows that transitivity is not a constant quality and that its status as a lexical property is problematic. At least in Finnish, transitivity emerges as the *possibility* of verbs having an object argument (see P. Leino 1991: 30-35). Therefore, in addition to syntax, the semantics of a sentence and the mapping between these two levels should be considered in verb analysis.

The second part of chapter 3 focuses on the mapping relations between syntactic, morphological and thematic arguments. I start by establishing the DA (direct argument)-linking of morphoroles. Here it is helpful to recall the rules determining intermediate DA-linking. Nikanne (1997c: 92, 88) states that argument linking is determined in the following order:

- (1) Identify the potential DAs following general DA derivation principles: (a) if a function in the lexical f-chain requires a theta-argument, then this theta-argument is a potential DA; (b) if a theta-argument is marked implicit (I) in the LCS, it is not a potential DA; (c) the potential DAs are ordered from left to right: DA1, DA2 (see also section 2.2.2).
- (2) The first potential DA in the thematic hierarchy is DA1.
- (3) The next potential DA in the semantic hierarchy is DA2.
- (4) Any other syntactic arguments must be licensed by structure-specific linking rules.

The argument linking in default cases can thus be illustrated as in (5):

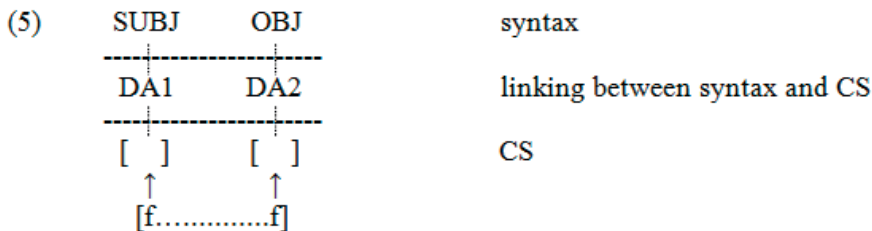

I assume that for the argument-linking of derived causatives it is important to consider the argument division of the root verb. For a more transparent description, I will include the morpholexical level (see also section 2.2.2) in the intermediate linking device. The morphorole level is assumed to be part of the linking system, located between the thematic tier and the DA level. The argument linking system of the CSDs study can be outlined as in (6):

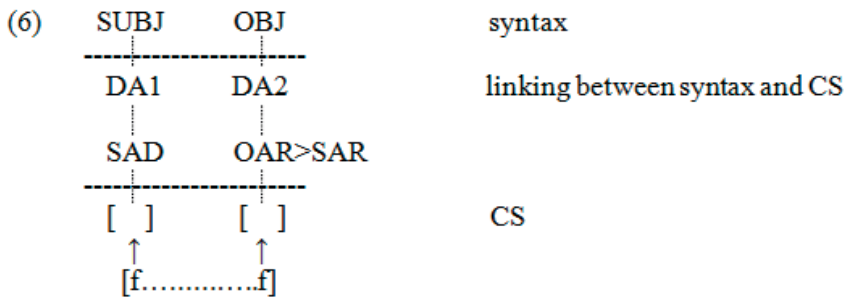

Figure (6) can be seen as the regular object-linking configuration for CSDs. The argument linking principles above suggest that if a potential DA is available, it fills the argument place. In addition, the default choice for the position of the DA2 is the OAR; if the OAR for some reason does not fill the DA2 position, it is available for the SAR. Hence, the DA2 arguments can be of different types, both semantically and regarding the morphoroles they are linked to. Consider, for instance, the following examples of the verb *ajattaa* ‘make s.o. drive’ in (7-9), illustrating the variety of DA2-fillers:

- |   |         |
|---|---------|
|   | SARpart |
|   |         |
| (7) <i>MM-Rallit: Skoda ajattaa <b>kahta suomalaista</b> Acropolis-rallissa.</i><br>Rally WC: Skoda-nom drive-caus two Finns-part Acropolis-rally-ine<br>‘Rally WC: Skoda puts <b>two Finns</b> behind the wheel at Acropolis rally’<br>( <a href="http://ralli.net/modules.php?name=News&amp;file=article&amp;sid=657">http://ralli.net/modules.php?name=News&amp;file=article&amp;sid=657</a> ,<br>24.10.2005)                                  |         |
|   | OARpart |
|   |         |
| (8) <i>Jos pidämme sitä tallin edun mukaisena, niin aiomme ajattaa <b>kolmatta autoa</b>, McLaren-tallista kommentoitiin tilannetta.</i><br>we will drive-caus third-part car-part<br>“‘If we consider it beneficial for the team, we will make [s.o.] drive a <b>third car</b> ,” said the McLaren team.’<br>( <a href="http://www.mtv3.fi/urheilu/f1/uutiset.shtml?336650">http://www.mtv3.fi/urheilu/f1/uutiset.shtml?336650</a> , 24.10.2005) |         |

?

- (9) *McLarenin olis pitänyt ottaa sellanen ihan pieni riski; ajattaa Kimillä vähän epäonnistunut aika*” [drive-caus Kimi-ade ”a bit failed time”-nom]  
 ‘McLaren should have taken a risk that small: making Kimi drive “a slightly weak time”.’  
 (www.ssbet.com/bb/?a=reply&t=205&r=905, 24.10.2005)

Examples (7-9) illustrate the flexibility of the argument structure of the verb *ajattaa* ‘make s.o. drive’ – not only the SAR (in 7) or the OAR (8) can assign the DA2 position, but also a phrase expressing the duration of the activity (9). The DA2 of (9) is a time expression in the accusative objective case characteristic of sports contexts (P. Leino 1991). Can this atypical object be regarded as a complement of the predicate verb<sup>32</sup>? Note that sentence (9) also includes the SARade; according to the regularity stated in principle II in section 3.1.3, there must be a constituent in the object position, an OAR or OAD, in order to license the SARade. The object of (9), *vähän epäonnistunut aika* ‘a slightly weak trial time’, is perhaps not a prototypical object, but we can interpret it as a *potential* object. In order to define the structure-specific linking rule to describe cases like (9), we need an exacter notion for diverse non-typical objects like measure phrases and adverbials of duration and frequency. I refer to this kind of optional complement of a verb using the abbreviation **ORadj**. The ORadj is defined in (10):

- (10) **ORadj** – the optional object or adjunct of the root verb in the object place

I assume that even though the ORadj is not a lexically determined argument, it is linked to syntax via the DA level. The linking relation of the ORadj is described in (11):

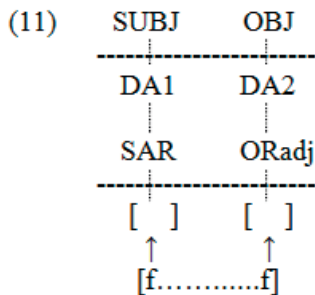

<sup>32</sup> There are verbs with exceptional argument linking like *lähestyä* ‘to approach’, *sisältyä* ‘to be included in’ and *saada* ‘to receive’. See the analysis in Nikanne (1994).

Hence the ORadj can also be linked to the object position in Finnish (compare (6) and (11)), and there are three potential DA2s on the morpholexical level: SAR, OAR and ORadj. We will return to the linking of the ORadj in sections 3.3.3-3.3.4. The argument above suggests that there is a hierarchy determining the DA2 linking of CSDs to the morpholexical level, formulated in (12). Note that the OAR is ranked higher than the SAR in DA2 selection (recall also principle III in section 3.1.3, which states that the SAR is in the second position after the OAR in order to be licensed as the DA2).

(12) OAR > SAR > ORadj

The argument above suggests that when the DA2 position is filled, the sentence has an object, reflecting the idea that verb transitivity is a flexible linguistic rule. Potentially, every verb is transitive if it has a linguistic element in the object position, and intransitive if it occurs without it. This can be seen as a simple approach to syntax – from the syntactic point of view, it is not essential what kind of object is in the object position. The flexible nature of verb transitivity supports the idea that regularities in grammar may differ in how absolute they are – there can be grammatical principles with definite status and those with flexible or prototypical status.

### 3.3 Lexical conceptual analysis of test verbs

In the previous sections we examined the syntactic properties of CSDs using examples of different types of root verbs and determined the general linking system that governs mapping between the morphorole and DA system. The next step is to integrate the morphology and syntax with the conceptual structure analysis of CSDs. The intermediate linking level, including the DA system and the morphoroles, is also included in this analysis. The conceptual structure analysis relevant to the present purposes comprises the thematic tier with the temporal structure, where needed. The focus is here is on linking system analysis in particular, not an exhaustive semantic description of the verbs. In order to keep the thematic tier analysis as simple and readable as possible, I will leave out the feature analysis (the organization of conceptual structure is discussed in section 2.2.1). Action tier functions are not included in this study, since the action tier is not assumed to be relevant to argument-linking (see Nikanne 1004: 206); the action tier of CSDs is the subject matter of chapter (5).

My aim in sections 3.3.1–3.3.3 is to examine the LCS of the six verbs tested in different syntactic surroundings in section 3.1. For each verb I will analyse the a-sentences, regarded as the complete prototypical sentences of the CSDs, and additionally the sentences that appear to be ‘clear’; the results of both the syntactic and language instinct tests will be taken into

consideration. I expect the conceptual analysis to reveal the lexical properties of the verb in question. The main questions are thus the following:

- What is the conceptual structure of the verbs tested in section 3.1?
- How does linking from the LCS to the morphorole level and syntax function, and does the inclusion of the morpholexical level benefit lexical analysis?
- What are the well-formedness conditions that make the sentences ‘good’ CSD-sentences?
- What does the analysis reveal in relation to the CSD prototype patterns defined in section 2.4.2?
- What are the consequences regarding the notion of transitivity?

I expect these aspects to provide an insight into the matter of the lexically encoded information of the verbs in focus.

### 3.3.1 High transitivity verbs

I will begin the conceptual structure analysis with the high transitivity verbs *ompeluttaa* ‘make s.o. sew’ and *teettää* ‘make s.o. do’. The syntactic test in section 3.1 indicates that the ‘clear’ sentences with these verbs are the a- and b-sentences with the structures [SAD, OARobj, SARade] and [SAD, OARobj] respectively. There is one difference compared to the syntactic test: the c- and d-sentences of *ompeluttaa* are not marked as being unclear here, due to the results of the language instinct test (see the discussion in section 3.1.4.4):

(1) *ompeluttaa* ‘make s.o. sew’: *ompele* + *ttA* [sew-caus]

a. Matti ompeluttaa Pekalla puvun/pukua.	Matti sew-caus-3sg Pekka-ade dress-acc/-part
b. Matti ompeluttaa puvun/pukua.	Matti sew-caus-3sg dress-acc/-part
c. Matti ompeluttaa Pekkaa.	Matti sew-caus-3sg Pekka-part
d. Matti ompeluttaa Pekalla	Matti sew-caus-3sg Pekka-ade
e. #Matti ompeluttaa Pekan komeaksi.	Matti sew-caus-3sg Pekka-acc handsome-tra
f. #Matti ompeluttaa Pekan.	Matti sew-caus-3sg Pekka-acc

(2) *teettää* ‘make s.o. do’: *teke* + *ttA* [do-caus]

a. Matti teettää Pekalla talon/taloa	Matti do-caus-3sg Pekka-ade house-acc/-part
b. Matti teettää talon/taloa.	Matti do-caus-3sg house-acc/-part
c. #Matti teettää Pekkaa	Matti do-caus-3sg Pekka-part
d. #Matti teettää Pekalla.	Matti do-caus-3sg Pekka-ade
e. #Matti teettää Pekan aikuiseksi.	Matti do-caus-3sg Pekka-acc adult-tra
f. #Matti teettää Pekan.	Matti do-caus-3sg Pekka-acc

The semantics of *ompeluttaa* and *teettää* are associated with production verbs. According to Pajunen (2001: 162-163), production verbs express the making of an entity from a material, the change in a form of an entity from one to another, or the making and creating of something (for instance food); typically, the object would not exist without the activity expressed by the verb. I assume that production verb structure can in general be analysed as in (1). The subordinating function BY expresses the actual type of production. What distinguishes the production verbs is that the theme referent undergoes a forming process. In an atelic situation, the process is directed towards a final shape (the ‘whole’) of the theme, whereas in a telic event, the result is reached and the product is complete (expressed by the function TO).

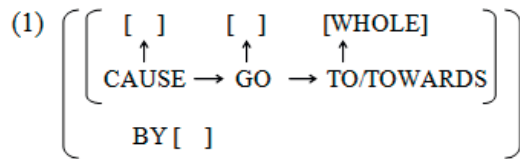

Analysis of the LCS and the linking relations of sentence (1a) *Matti ompeluttaa Pekalla puvun* ‘Matti has Pekka sew the dress’ is given in (2). The verb *ompeluttaa* ‘make s.o. sew’ encodes the production verb properties with an additional causation. According to Framenet<sup>33</sup>, the verb root adapts the attaching frame, covering two situations: “a scene in which somebody causes one thing to be physically connected to something else; or a scene in which somebody causes two things to be connected to each other”. The manner of connecting the objects is characteristically making stiches using a needle and thread. This is compacted in (2) into the BY phrase; the scope of BY covers the structure within the nearest brackets:

- (2) *Matti*<sub>3</sub> *ompeluttaa*<sub>1</sub> *Pekalla*<sub>4</sub> *puvun*<sub>5</sub>.  
 Matti sew-caus-pres-3sg Pekka-ade dress-acc  
 ‘Matti has Pekka sew the dress for him.’

<sup>33</sup> Lexical information on ‘to sew’ was sought from the framenet homepage at <http://framenet.icsi.berkeley.edu>.



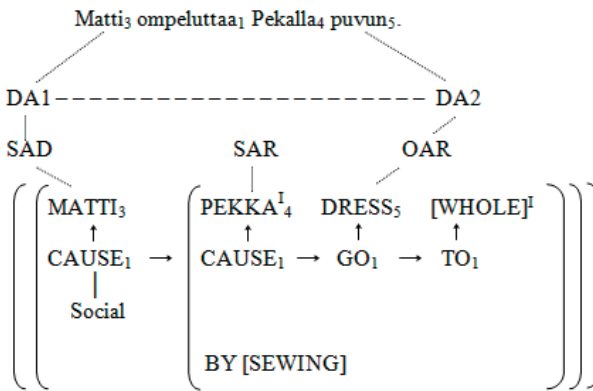

The verb *ompeluttaa* ‘make s.o. sew’ in the LCS of sentence (2) has two DA arguments linked to the thematic arguments causer (‘Matti’) and theme (‘dress’). The arguments with the DA status are the SAD and the OAR; the SAR appears as the implicit agent, marked with index I, and is thus not a potential DA. The semantic field of the first causation is social; in order to keep the CS description as simple as possible, I do not analyse other semantic fields here.

The structure of the b-sentence *Matti ompeluttaa puvun* ‘Matti had the dress sewn’ differs from (2) only in that the implicit SAR is not syntactically expressed; therefore I will not carry out a separate analysis of this sentence.

According to the language instinct test, the sentences *Matti ompeluttaa Pekalla* of the structure [SAD, SARade] and *Matti ompeluttaa Pekkaa* [SAD, SARpart] (both can be translated roughly ‘Matti had Pekka sew’) were accepted with relatively high results. These sentences belong to the intermediate group of acceptance, occupying tenth and eleventh places respectively (see (3) in 3.1.4.4). Since *Pekka* in the sentence *Matti ompeluttaa Pekalla* was in most (15) cases interpreted as the SAR, this affects the general LCS of *ompeluttaa* by leaving the theme argument arbitrary. The focus of the sentence is not on the result of the sewing but on the sewing itself; we do not know if the object being sewn will be completed or not. The verb *ompeluttaa* lacks its production verb feature in this sentence, manifested through the implicit goal argument ‘whole’, given that the condition of production is that a product is completed. Thus, in this sentence, this CSD functions as an intransitive verb focusing on the activity. The sentence *Matti ompeluttaa Pekalla* is analysed in (3). The significant aspect of this structure is the linking configuration of (3). Note that it has only one DA argument, because no syntactic object is expressed in this sentence. Also, the OAR is not expressed.

(3) *Matti ompeluttaa Pekalla*

Matti sew-caus-pres-3sg Pekka-ade dress-acc  
 ‘Matti had Pekka sew.’

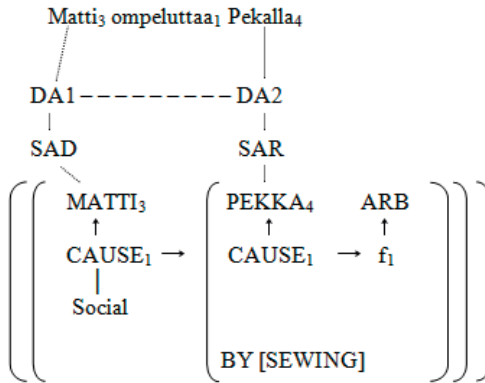

The c-sentence *Matti ompeluttaa Pekkaa* (17) of the structure [SAD, SARpart] also proved that a high transitivity CSD allows the actor-SAR to occur in the partitive case according to the language users’ intuition. As was discussed in 3.1.4.1, 11 test subjects out of 20 encoded the sentence with *Pekka* as the actor-SAR. Analysis of this sentence thus corresponds in general to the previous structure. The difference lies in the linking configuration: the DA2 is assigned and linked to the SAR, but the OAR is also understood here as an arbitrary argument. Also here, the focus is on the sewing itself, not what is sewn. Notice that the DA2 here is linked to the zone 3 argument. Consider the analysis in (4):

(4) *Matti ompeluttaa Pekkaa*

Matti sew-caus-pres-3sg Pekka-part  
 ‘Matti had Pekka sew.’

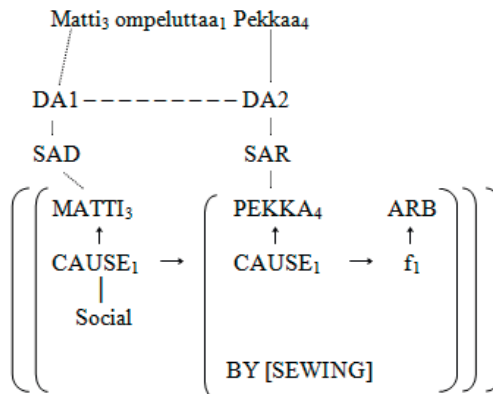

In summary, we can also draw conclusions about the semantics of the verb *ompeluttaa* by considering the consequences of (3) and (4): as a verb becomes an activity verb, the meaning of the root verb is no longer the focus. The lexical entry of *ompeluttaa* can be described as in (5); the description is a recognition of the fact that the verb meaning involves various aspects that are not all visible in its argument structure. The stripped-down form of (5) reflects the ability of this verb to show both the properties of the production verb as well as the activity verb. In other words, even a CSD can apply the activity verb pattern and abandon the resultative characteristics of a highly transitive verb.

(5) Lexical entry of *ompeluttaa* ‘make s.o. sew’

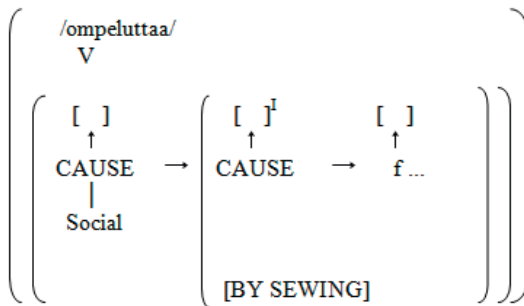

The second high transitivity verb in the syntactic test is *teettää* ‘make s.o. do/make’. This verb can be regarded as a hypernym for production verbs displaying a considerably larger extensional scope than *ompeluttaa* ‘make s.o. sew’. The actual type or manner of activity depends highly on the theme referent, whose nature is not specified in the lexical entry of *teettää*. Therefore, the LCS of *teettää* does not include a subordinating structure (like the BY structure of *ompeluttaa*) specifying the manner of the making in question. Hence, the role of theme argument is crucial to the meaning of the sentence; without the OAR, the meaning is incomplete. It is also the OAR that enables us to specify the way the theme is processed (and possibly to add the BY structure). Because of the obligatory nature of the OAR argument, I consider the sentence types [SAD, SARade] and [SAD, SARpart] unclear in connection with *teettää*, even though these structures were found acceptable with *ompeluttaa*. In other words, Pekka cannot be interpreted as the SAR in the c- and d-sentences.

There are consequently only two clear sentences with similar DA2-OAR linking: the a- and b-sentences. The a-sentence *Matti teettää Pekalla talon/taloa* ‘Matti has Pekka build the house’ is analysed in (6). As we can see, the conceptual analysis and the linking relations here are almost identical to the a- and b-sentences of *ompeluttaa* (compare to (1)). Also, the lexical

entry of *teettää* given in (7) corresponds to that of *ompeluttaa* (compare to (4)), with the difference being that the manner of activity is not specified, but the root verb structure maintains the character of the production verb.

(6) *Matti teettää Pekalla talon*

Matti do-caus-pers-3sg Pekka-ade house-acc/-part  
 ‘Matti has Pekka build the house’

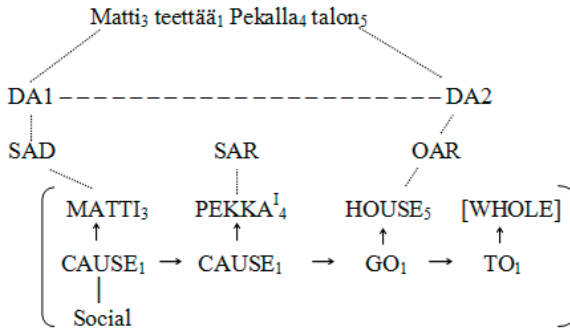

(7) Lexical entry of *teettää* ‘make s.o. do/make’

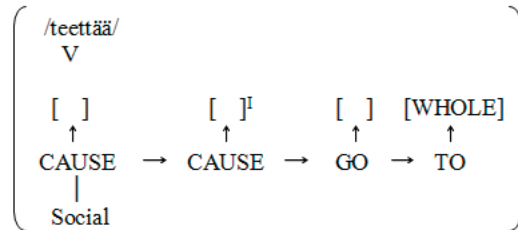

Based on the analyses in (2) and (6), we can generalise the conceptual structure and linking relations of high transitivity production verbs as in (8):

(8) Structure and linking system of high transitivity verbs – SARade-structure

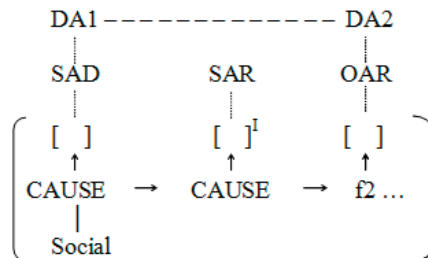

Nevertheless, as was discussed with example (4), high transitivity CSDs also enable the linking of the SAR to the DA2. Thus, the linking configuration in (9) is also valid for high transitivity CSDs.

(9) Objective SAR structure

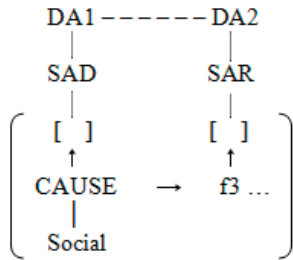

Why do language users accept the DA2 linking to the SAR as in example (3)? The explanation can be found in the prototype structures as briefly defined in section 2.4.2. Whereas the linking configuration of (8) corresponds quite directly to prototype 1, the pattern in (9) matches prototype 2. Thus, the intermediate argument linking configuration (the DA and morphorole level) determines which prototype the structure belongs to. An outcome of the analysis in this section is that a high transitivity CSD can be associated with both prototype patterns. I present the CSD prototypes anew in (10) and (11):

(10) Prototype 1

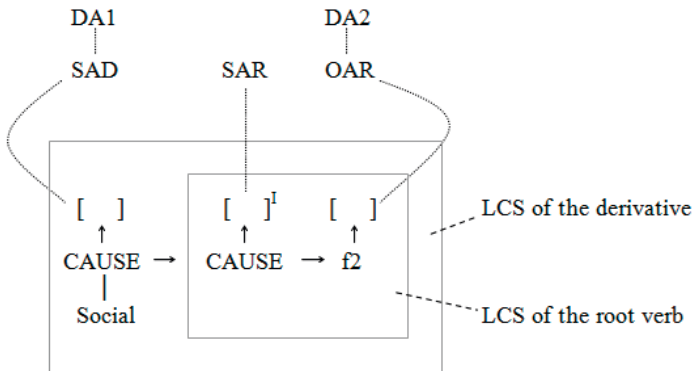

## (11) Prototype 2

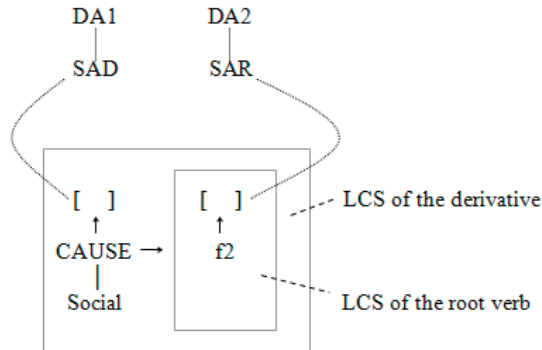

The structure in (9) suggests that the second function of prototype 2 can also be an f3; therefore, prototype 2 is reanalysed as in (12). The bare f in (12) stands for a zone 3 or zone 2 function.

## (12) Reanalysis of prototype 2

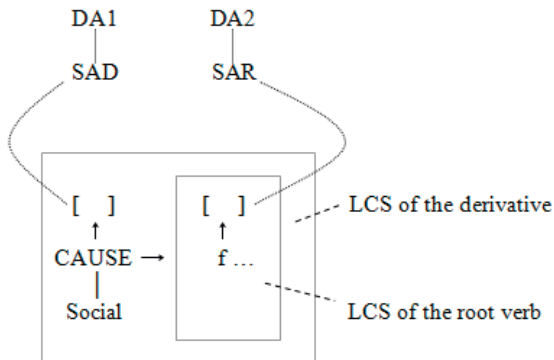

In respect to the general linking relations of CSDs derived from roots that are regarded as high transitives, I conclude that these cannot be restricted to correspond to the prototype 1 pattern only. These verbs may adapt the prototype 2 linking pattern even by maintaining two causations in their LCS. The effect of the prototype patterns can be seen as a background to the unexpectedly high acceptance of the sentences [SAD, SARade] and [SAD, SARpart] by the test subjects in the language instinct test carried out as part of this study. The structure analysed in (3) in this section, with its exceptional linking arrangement, adds ambiguity to high transitivity CSDs. Since this sentence is objectless, there is no DA2 and the SAR is mapped to the adessive adjunct. This shows that a CSD is able to occur in an intransitive

sentence pattern even when derived from a highly transitive root verb, indicating that transitivity cannot be regarded as a property of the lexical level. In respect to prototype patterns, this example indicates that there can be aberrations from general linking patterns; the prototypes are thus not static constructions.

### 3.3.2 Medium transitivity verbs

Both the syntactic test in section 3.1.3 and the language instinct test in 3.1.4 indicated that medium transitivity CSDs adjust to most of the tested sentence structures; the only unclear sentence structure with these verbs is [SAD, SARade] (by way of comparison, in connection with the high transitivity derivative *ompeluttaa* ‘make s.o. sew’, this structure was rated as clear by the test subjects: recall example (3) in the previous section). Compared to other CSDs in the syntactic test, the medium transitivity group can be considered to be the verbs with the most flexible argument structure (as the language instinct test results from section 3.1.4.4 showed, where the sentences using *syötättää* ‘make s.o. eat’ received high positions on the standard deviation scale). The medium transitivity CSD sentences focused on in the syntactic test were thus the following:

#### (3) *syötättää* ‘make s.o. eat’: *syöttä* + ttA [eat-caus-caus]

a. Matti syötättää Pekalla puuron/ puuroa.	Matti eat-caus-3sg Pekka-ade porridge- acc/-part
b. Matti syötättää puuron/puuroa.	Matti eat-caus-3sg porridge-acc/-part
c. Matti syötättää Pekkaa.	Matti eat-caus-3sg Pekka-part
d. #Matti syötättää Pekalla.	Matti eat-caus-3sg Pekka-ade
e. Matti syötättää Pekan kylläiseksi.	Matti eat-caus-3sg Pekka-acc full-tra
f. Matti syötättää Pekan.	Matti eat-caus-3sg Pekka-acc

#### (4) *laulattaa* ‘make s.o. sing’: *laula* + ttA [sing-caus]

a. Matti laulattaa Pekalla joululaulun/ joululaulua.	Matti sing-caus-3sg Pekka-ade Christmas.carol-acc/Christmas.carol-part
b. Matti laulattaa joululaulun/ joululaulua	Matti sing-caus-3sg Christmas.carol-acc/ Christmas.carol-part
c. Matti laulattaa Pekkaa.	Matti sing-caus-3sg Pekka-part
d. #Matti laulattaa Pekalla.	Matti sing-caus-3sg Pekka-ade
e. #Matti laulattaa Pekan iloiseksi.	Matti sing-caus-3sg Pekka-acc glad-tra
f. Matti laulattaa Pekan.	Matti sing-caus-3sg Pekka-acc

The CSDs in the medium transitivity group in the test, *syötättää* ‘make s.o. eat’ and *laulattaa* ‘make s.o. sing’, are derived from root verbs with an implicit patient: a theme argument. Since deriving a verb as a CSD signals the addition of an implicit agent, the derivatives of implicit theme verbs include *two* implicit arguments in their LCS. This can also be seen in the first

sentence with the verb *syötättää*; consider the conceptual structure of the a-sentence *Matti syötättää Pekalla puuron/puuroa* in (1). Two arguments are fused with an implicit argument in (1); the adessive adjunct (the SAR) is the argument of second causation PEKKA and the object argument (also the OAR) is the theme PORRIDGE. The DA-linking of (1) functions as in prototype 1 (see (10) in the previous section): the SAD has the status of DA1 and the OAR the status of DA2.

- (1) *Matti syötättää Pekalla puuron/puuroa*  
 Matti eat-caus-pres-3sg Pekka-ade porridge-acc/porridge-part  
 ‘Matti makes Pekka eat the porridge.’

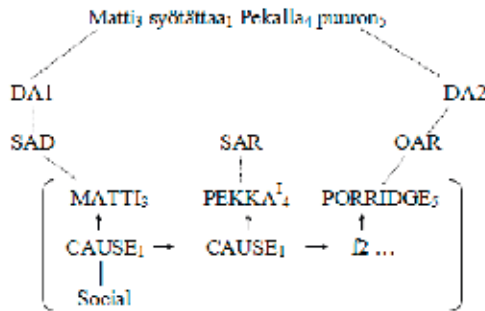

The lexical meaning of the verb ‘to eat’ is especially complicated to describe, as it encodes a complex physiological process, social happening and even psychological aspects. The semantic fields of the second causation in (1) as well as in zone 1 and 2 are difficult to define. The activity of the eater is characterized by several aspects: the eater places food in their mouth, chews it and swallows it; takes its nutrition as necessary sustenance; and performs a motor action in a social situation. Eating, as a basic human activity and need, is associated with socio-cultural customs and habits. How can we describe the effect of eating on the eater once they have had enough? The transition of theme (FOOD) adds to the complexity of the meaning of the verb. During the eating process, the amount of food decreases; ‘food’ thus corresponds to the incremental theme in Dowty’s (1991: 567) terms. Is the bound nature of the eating situation delimited through the satiety of the eater or the amount of food left? In Finnish, the alternation of object cases between accusative and partitive affects the LCS of the sentence in (1) so that in both cases *Pekka* eats porridge; the accusative indicates that the portion of porridge is going to be completely eaten, but in the case of the partitive object, this is not necessarily the case (this is not analysed in (1); for the aspectual nuances of *syödä* ‘to eat’, see Nikanne 2006: 217-218). Since an exhaustive analysis of the root verb *syödä* is not the main issue here, I leave the complex semantic phenomenon open by not specifying the zone 1 and



zone 2 functions in the analysis of (1). Nor do I specify here semantic fields other than the first (social) causation, which is the relevant part of this analysis.

Next, consider the b- and c-sentences of *syötättää* ((3b) and (3c) in the syntactic test). The b-sentence [SAD, OAR] and c-sentence [SAD, SARpart] differ from each other in that their object arguments are linked to different morphoroles. In (b), the DA2 is linked to the OAR (PORRIDGE) and in (c) to the SAR (PEKKA). Thus, both the OAR and SAR assign the object position:

b. *Matti syötättää puuron/puuroa.*

Matti eat-caus-pres-3sg porridge-acc/-part  
'Matti makes s.o. eat the porridge'

c. *Matti syötättää Pekkaa.*

Matti eat-caus-pres-3sg Pekka-part  
'Matti makes (s.o. make) Pekka eat'

How is the object argument alternation expressed in the conceptual structure analysis? The linking configuration of the b-sentence is analogous to the a-sentence (see (1)), with the exception that the SAR is not expressed in syntax. Therefore, it is not necessary to provide an extra analysis of that sentence. The c-sentence involves two different readings, analysed in (2a) and (2b). As the language test in 3.3.2 indicated, because of the double causative suffix *ttA-ttA*, the verb *syötättää* can be interpreted in two ways regarding the number of actors participating in the activity. There was no consensus about the derivation degree of this verb (13 responses gave interpretations involving an intermediate actor and seven without one). Hence the structure (2a) describes a situation where Matti has an unspecified participant (the SAR2) make Pekka eat, for instance in the event that Pekka is unable to eat himself (e.g. if he is in hospital). In this case, the SAR1 (PEKKA) is not the second causer as in (1) but the theme. The implicit causer, the actual feeder, hands the food (implicit theme) to PEKKA. The actors are marked as SAR1 (PEKKA) and SAR2 in (2a), as in the language instinct test analysis of the *syötättää* sentences (see 3.1.4.2). The analysis in (2b) describes a situation without the intermediate agent, the SAR2, being involved. The linking configuration here corresponds to prototype 2.

(2a)

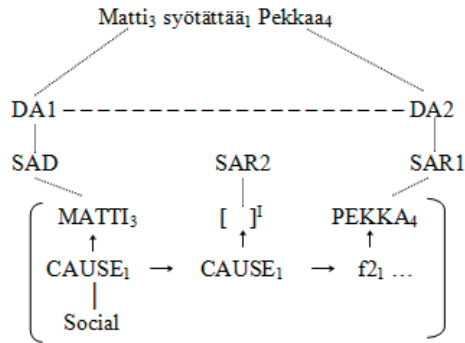

(2b)

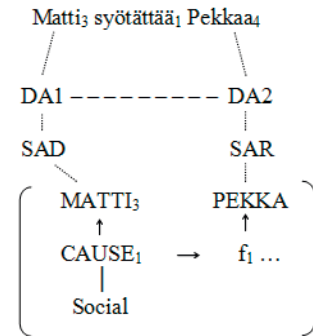

The analysis of *syötättää* in the resultative construction i.e. the e-sentence [SAD, SARacc, RESADJtra] is given in (3). The result is expressed by a subordinate structure; the semantic field ‘characterizing’ describes the transition in the indexed argument PEKKA. Because most of the paraphrasing of this sentence reflected the argument structure with an intermediate actor in the language instinct test, I include SAR2 in the analysis in (3):

(3) *Matti syötättää Pekan kylläiseksi*

Matti eat-caus-pres-3sg Pekka-acc satisfied-tra

'Matti made s.o. make Pekka eat until he had had enough.'

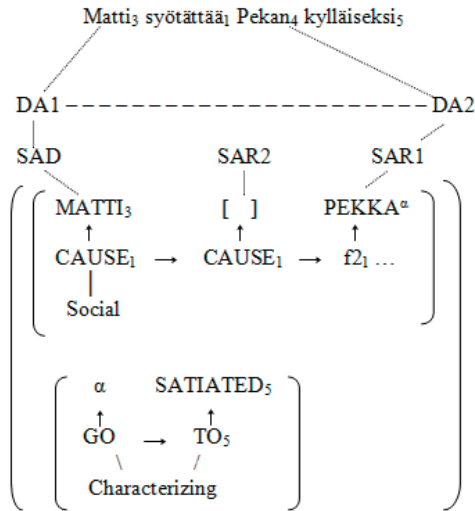

Regarding the complexity of the verb *syötättää*, recall also the language instinct test responses to this verb, including the negative connotations regarding the *syötättää* situations, indicating that Matti forces Pekka to eat food that nobody else wants. This suggests that the activity of the SAR can obtain the feature [-vol]; the feature [+vol] can be seen as the default case with this verb. Obviously, the argument structure alternations change the focus of the proposition, and the semantic contribution of the type of food in question may vary. This underlines the particularly subtle nature of the root verb *syödä* and the complexity of its semantic description. However, this should not stop us in our attempt to provide a lexical description of *syötättää*, especially because the examples discussed here suggest that in relation to the root verb *syödä* this derivative additionally obtains individual characteristic features. Hence, I will analyse the lexical entry of *syötättää* in (4) in its reduced form, but strive to include the crucial properties in the picture. The second thematic function in the f-chain in (4) is a plain f, leaving it open as to whether it is a zone 3 or zone 2 function. As we saw, *syötättää* is not a coherently double or single causative prototype verb. Therefore, the implicity of the second argument is also given in angled brackets, denoting the optionality of the notion.

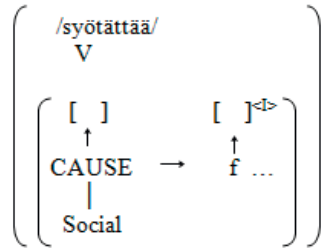
(4) Lexical entry of *syötättää* ‘make s.o. eat’

The next medium transitivity verb in the test was *laulattaa* ‘make s.o. sing’. According to the syntactic test, the clear sentences are here the same as those with *syötättää*. As in connection with *syötättää*, the semantics of *laulattaa* also involve complex aspects, for instance regarding the processes that the SAR and OAR undergo. In the case of *laulattaa* we can say that there is a certain change in state of the SAR (PEKKA) and the OAR (TUNE). The singer (PEKKA) is in the state of making music using his vocal cords i.e. his own body, but does he undergo any change? What happens to the song he sings? On the one hand, the song is basically the same, whoever the singer is. On the other hand, every performance is unique, and even the same singer cannot reproduce a song in exactly the same way. I start the analysis with the a-sentence of *laulattaa* of the structure [SAD, OARobj, SARade] in (5):

(5) *Matti laulattaa Pekalla joululaulun*

Matti sing-caus-pers-3sg Pekka-ade Christmas carol-acc  
 ‘Matti makes Pekka sing a Christmas carol.’

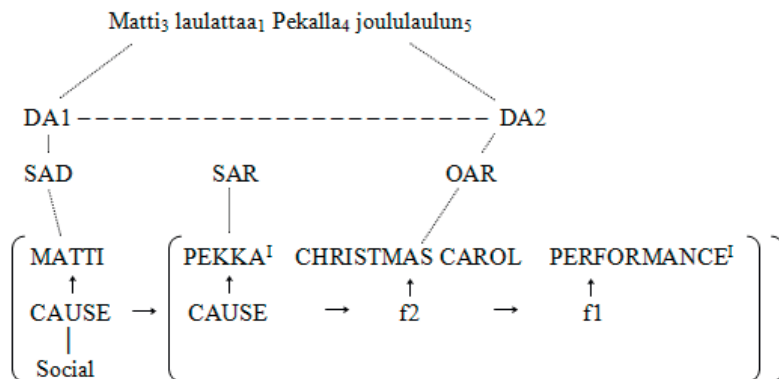

As we can see in (5), the DA2 is here mapped to the OAR (CHRISTMAS CAROL), the argument fused with the implicit theme. The root verb *laulaa* ‘to sing’ displays special nuances of the semantic field that do not clearly

correspond to the fields presented in 2.2.1. The semantic fields as such are not the focus of this study; therefore, I concentrate here on the relevant aspects of the analysis. I leave the problems related to this special area for future research, and mark only the semantic field of first causation.

I will not analyse the b-sentence *Matti laulattaa joululaulun/joululaulua* of the structure [SAD, SARacc/part] separately, since it differs from the previous analysis only in that the SAR (PEKKA) does not appear syntactically. Also, the resultative construction of *laulattaa* i.e. the e-sentence corresponds to the analogous structure in connection with *syötättää* (see (3)); therefore it is not necessary to analyse it here.

The structure [SAD, SARpart] of *laulattaa* is examined in (6). The analysis of this sentence in (6) shows that the OAR is not expressed and the SAR assigns the position of DA2. This is an atelic/unbound situation, because the object appears in the partitive case.

(6) *Matti laulattaa Pekkaa.*

Matti sing-caus-pres-3sg Pekka-part  
‘Matti makes Pekka sing.’

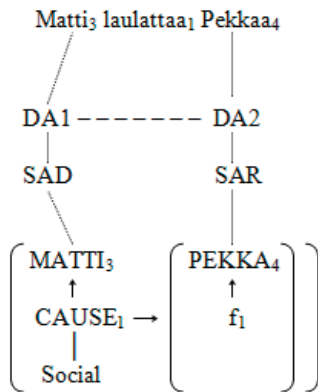

The lexical entry of *laulattaa* is given in (7). The second thematic function in the f-chain in (7) is an f, which means that this verb is open in the sense of the number of causations. The notion f does thus not specify if the second function belongs to zone 3 or zone 2, reflecting the possibility of this verb occurring as either a double or single causative. Therefore, the implicity of the second argument is given in angled brackets.

(7) Lexical entry of *laulattaa* ‘make s.o. sing’

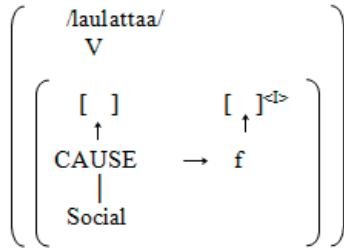

We can conclude that the flexibility of the medium transitivity verbs discussed in this section is mainly due to the ‘optional’ DA2 linking. The crucial question regarding the linking realisation of these verbs is which argument is mapped to the DA2. The DA2 of these verbs may be linked to the OAR or the SAR, as encapsulated in (8a-b). Thus, both the prototype 1 and prototype 2 linking configuration are represented by these verbs.

(8a) Structure and linking system of medium transitivity verbs – SARade structure

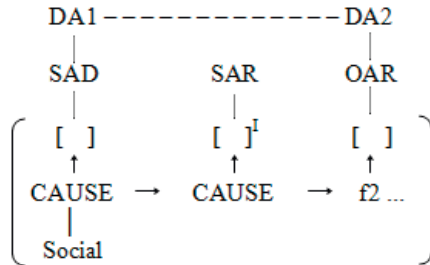

(8b) Objective SAR structure

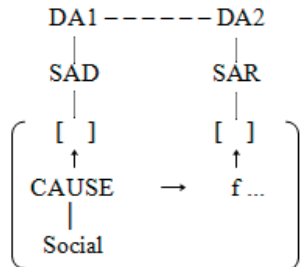

### 3.3.3 Low transitivity verbs

The third verb group in my test are CSDs derived from root verbs that can be considered as low transitives: *juoksuttaa* ‘make s.o. run’ and *jonotuttaa* ‘make s.o. queue’. The syntactic test in 3.1.3 indicated that the clear sentences in connection with these verbs were the c- and e-sentences i.e. the structures [SAD, SARpart] and [SAD, SARacc, RESADJill]. Remarkably, the second low transitivity verb, *jonotuttaa* ‘make s.o. queue’, differs from all of the other tested CSDs in that the a-sentence is not clear; the language instinct test showed that this was the only [SAD, OAR, SARade] sentence that was placed in the unclear sentence group (see (3) in section 3.1.4.4). This is also one of the sentences that was understood quite well (the rewordings showed that the language users had created appropriate situational surroundings for it (see 3.1.4.3) despite the low assessments). However, the a-sentence structure is clear in connection with the first low transitivity CSD, *juoksuttaa* ‘make s.o. run’. Consider the sentences with *juoksuttaa* and *jonotuttaa*:

#### (5) *juoksuttaa* ‘make s.o. run’ juokse + ttA [run-caus]

a. Matti juoksuttaa Pekalla lenkin/lenkkiä	Matti run-caus-3sg Pekka-ade turn-acc/-part
b. #Matti juoksuttaa lenkin/lenkkiä.	Matti run-caus-3sg turn-acc/-part
c. Matti juoksuttaa Pekkaa.	Matti run-caus-3sg Pekka-part
d. #Matti juoksuttaa Pekalla.	Matti run-caus-3sg Pekka-ade
e. Matti juoksuttaa Pekan kaupunkiin/uuvuksiin	Matti run-caus-3sg Pekka-acc city-ill/exhausted-ill
f. #Matti juoksuttaa Pekan.	Matti run-caus-3sg Pekka-acc

#### (6) *jonotuttaa* ‘make s.o. queue’ jonotta + ttA (queue-CAUS)

a. #Matti jonotuttaa Pekalla tunnin/*tuntia.	Matti queue-caus-3sg Pekka-ade hour-acc
b. #Matti jonotuttaa tunnin.	Matti queue-caus-3sg hour-acc
c. Matti jonotuttaa Pekkaa.	Matti queue-caus-3sg Pekka-part
d. #Matti jonotuttaa Pekalla.	Matti queue-caus-3sg Pekka-ade
e. Matti jonotuttaa Pekan uuvuksiin.	Matti queue-caus-3sg Pekka-acc exhausted-ill
f. #Matti jonotuttaa Pekan.	Matti queue-caus-3sg Pekka-acc

The first low transitivity CSD, *juoksuttaa*, is an activity verb denoting that the SAR is in motion. This verb differs from the high and medium transitivity CSDs discussed above in that it is a single causative i.e. there is only one causation in its LCS. Consequently, in the a-sentence of the structure [SAD, OARobj, SARade], the SAD is linked to the causer (MATTI) and the SAR (PEKKA) to the theme argument in the linking system of the analysis (1). The argument LENKKI can be classified here as the ORadj instead of the OAR. Notice that the semantics of the Finnish lexeme *lenkki* are dependent

on the form of motion in question; it can mean ‘a walk’, ‘a run’ or ‘a jog’. Another meaning of it is ‘a circle’. Since the predicate encodes motion by running, I translate *lenkki* as ‘a run’. The object referent is measuring out the running situation in Tenny’s (1994) terms; the accusative case adds the feature of the bound nature to the situation, which turns the activity into an accomplishment event.

- (1) *Matti juokсутtaa Pekalla lenkin*  
 Matti run-caus-pres-3sg Pekka-ade turn-acc  
 ‘Matti has Pekka go for a run.’

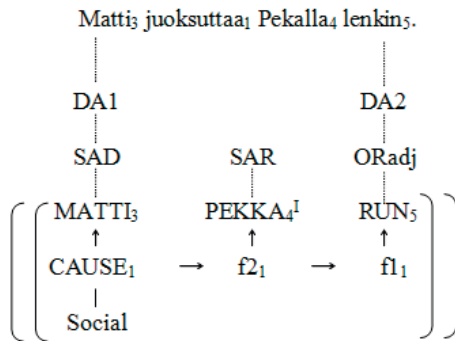

The significant aspect with the linking configuration in (1) is that its DA2 is not linked to the theme argument as with the previous verb groups in connection with sentence a. The object position is not assigned by the OAR, but the ORadj, connected with the location zone argument. The SAR is not mapped here to an implicit causer but to the (implicit) theme argument. The adessive adjunct bearing the role of an agent can thus even be mapped to a zone 2 function, which shows that the adessive SAR adjunct of CSDs is able to occur both in zone 3 and zone 2. The linking configuration in (1) implies that the assignment of the ORadj (recall the discussion of the Finnish object and the phenomenon of adverbials of amount in object cases in 3.1.1) follows the rules of the DA2 linking: the first potential DA next to the DA1 is licensed as the DA2. We can hence infer that the difference between high transitivity CSDs and low transitivity CSDs is in the conceptual structure and linking system, not in syntax. The SAR in the adessive case is also possible in connection with low transitivity CSDs, although the linking configuration that allows the ORadj to be linked to the object position in syntax does not follow the double-causative prototypical pattern (as defined in 2.4.2). Thus, a single causative CSD is also able to adapt the prototype 1 structure.

The SAR of *juokсутtaa* also occurs in the partitive case in the structure [SAD, SARpart]; consider the analysis of the c-sentence in (2). In this case, the DA-linking follows the regular linking rule: the SAR (PEKKA) is selected as the DA2; the PATH, the f1 argument, is implicit.



(2) *Matti juokсутtaa Pekkaa*

Matti run-caus-pres-3sg Pekka-part

'Matti makes Pekka run.'

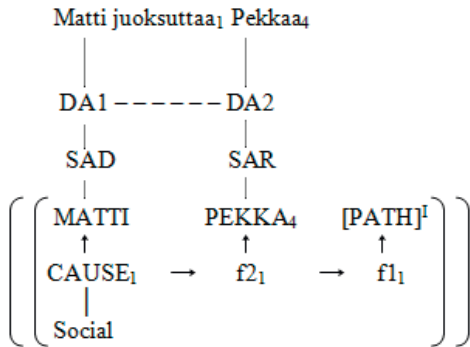

The resultative sentence structure [SAD, SARacc, RESADJill] of *juokсутtaa* is a clear sentence. An analysis of the e-sentence is given in (3); similar to the previous analysis, the DA2 is linked to the SAR. Note that the SAR (PEKKA) is here coindexed with the theme of the substructure describing the result.

(3) *Matti juokсутtaa Pekan uuvuksiin.*

Matti run-caus-pes-3sg Pekka-acc exhausted-ill

'Matti makes Pekka run himself exhausted.'

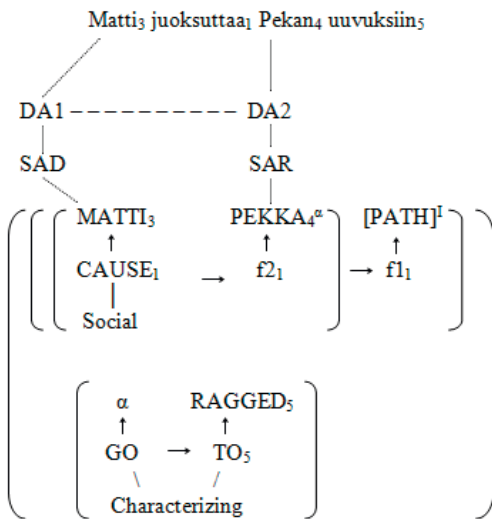

The test sentence (5b) *Matti juoksuttaa lenkin/lenkkiä* of the structure [SAD, OAR] lacks the SAR and is marked as an unclear sentence in the syntactic test. But why is this sentence unclear? The explanation is found in the conceptual structure of *juoksuttaa*: the argument LENKKI ('a run') is fused with the implicit path, but since the proposition lacks the theme argument, there is no participant moving on this path. In other words, the explicit SAR is needed in connection with this verb, unless the proposition has a generic sense.

The lexical entry of *juoksuttaa* 'make s.o. run' is analysed in (4):

(4) Lexical entry of *juoksuttaa* 'make s.o. run'

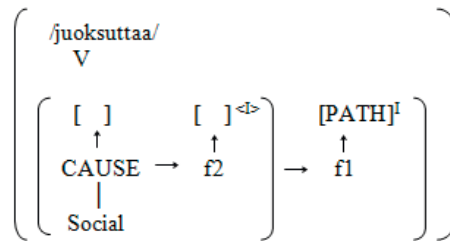

The root verb of the second low transitivity CSD *jonottaa* 'make s.o. queue' is *jonottaa* 'to queue'; this verb was also tested in the language instinct test in 3.1.4. This verb denotes an event where the subject argument remains in one place for a period of time for some purpose. In the thematic tier, this is expressed by the zone 2 function STAY indicating that the theme argument is located in a place. This place, with this verb, is an implicitly understood QUEUE. Notice that the function STAY expresses a temporally related situation, which distinguishes it from the 'be' function; the existence of the notion of time can be seen as the crucial difference between states and events in general (Nikanne 1990, Jackendoff 1990).

As mentioned at the beginning of this section, the a-sentence with *jonottaa* was placed in the unclear sentence group in the language instinct test. Nevertheless, I analyse the sentence *Matti jonottaa Pekalla tunnin* in the denotation that PEKKA is the SAR (it is not used for instance in the locative meaning 'at Pekka's place') in (5). The linking configuration of this structure of this sentence shows that the durative modifier *tunnin* 'for an hour' in the accusative objective case has the status of the ORadj. This time expression in the object position restricts the situation in respect to both the starting point and the endpoint, and its scope comprises zone 2 and zone 1. I do not include any further detailed lexical structure of the word HOUR here,

since it is not part of the LCS of the verb *jonotuttaa*<sup>34</sup>. The relevant aspect here is that the time adverbial refers to the temporal structure, related to the time segment restricting the queuing process. I include the temporal tier (T-tier)<sup>35</sup> in the LCS of (5). The ORadj is thus associated with the region of time (R) which in turn is restricted by points of time (P), which hold for both zone 2 and zone 1.

- (5) *Matti jonotuttaa Pekalla tunnin*  
 Matti queue-caus-pres-3sg Pekka-ade hour-acc  
 ‘Matti makes Pekka queue for an hour.’

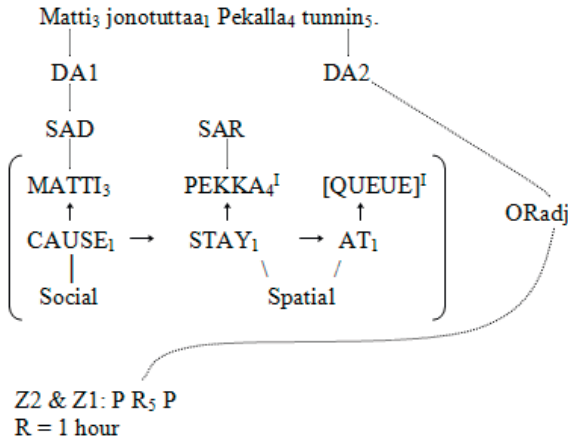

The DA2 linking of (5) is similar to the *juokсуттаа* example in (1): the ORadj is selected as the DA2. This also enables a CSD derived from a low transitivity base to function in the adessive agent-SAR structure. The sentence (5) can be interpreted because the ORadj has a place in syntactic structure, but a resultative object for the structure [SAD, OAR, SARade] seems to be required. This may be a reason why the sentence was seen as unclear in the language instinct test.

The c-sentence of the structure [SAD, SARpart] is analysed in (6). In this case, the SAR is linked to the DA2. Note that no restricting time expression is present, which turns the situation into an unbound one.

<sup>34</sup>For the conceptual structure of ‘hour’, see Nikanne (2005).

<sup>35</sup>The form of the T-tier is more specifically discussed in section (5.2.1).

(6) *Matti jonotuttaa Pekkaa*

Matti queue-caus-pres-3sg Pekka-part  
 ‘Matti makes Pekka queue.’

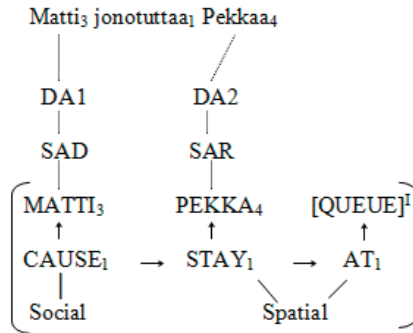

The resultative construction [SAD, SARacc, RESADJill] with the verb *jonotuttaa* is analogous to the analysis of this structure in connection with *juoksuttaa* in (3). Consider the analysis in (7):

(7) *Matti jonotuttaa Pekan uuvuksiin*

Matti queue-caus-pres-3sg Pekka-acc exhausted-ill  
 ‘Matti makes Pekka queue until he is exhausted.’

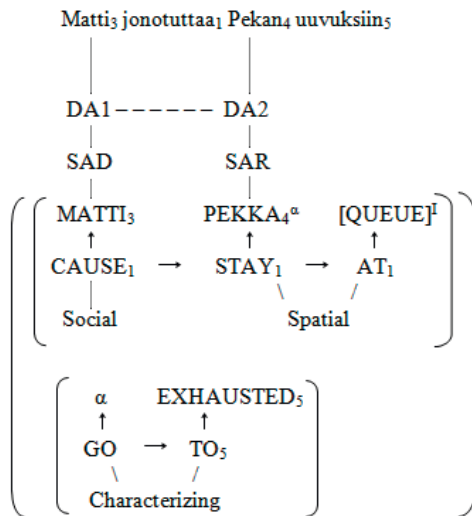

The lexical entry of *jonotuttaa* ‘make s.o. queue’ is given in (8):

(8) Lexical entry of *jonotuttaa* ‘make s.o. queue’

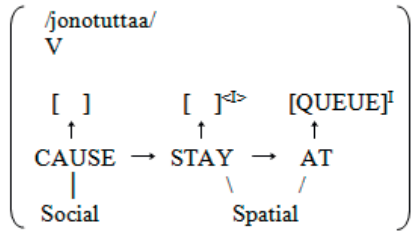

We can infer from the analysis in this section that low transitivity CSDs are able to assign the SAR both in object cases and in the adessive linked to the theme argument i.e. to a zone 2 function. This is important regarding the adessive adjunct rule (compare to the discussion on the adessive adjunct in section 3.1.2) in relation to CSDs: the actor-SAR expressed in the adessive can be both a zone 3 and a zone 2 argument. Low transitivity CSDs can assign an ORadj in the object position. The ORadj is mapped either with the location zone argument, as in example (1) or with an element outside the lexical structure of the verb, as in (5). The linking system of low transitivity CSDs also essentially corresponds here to both prototype structures; consider the structures in (9a-b). I simplify the analysis of the ORadj in (9a) by uniting the outside structure and location zone argument analyses as selected by an unspecified *f*.

(9a) Structure and linking system of low transitivity verbs – SARade structure

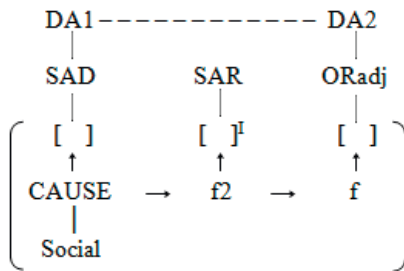

## (9b) Objective of SAR structure

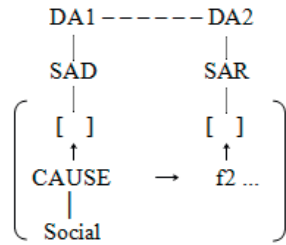

An additional observation can be made on the basis of the ORadj structure analysis in this section. The conceptual structure analysis of the elements linked to the ORadj shows an interesting tendency in comparison to the case-hierarchy hypothesis of Maling (1993), presented briefly in section 3.1.1. In her account of object-like phrases, adverbials of amount in object cases expressing measure have a higher position than adverbials of duration regarding the case assignment hierarchy. In other words, MEASURE phrases are considered to contain more object-like qualities than DURATIOON adverbials. This hypothesis seems to be supported at least by findings in connection with low transitivity CSDs as analysed here: the measure ORadj LENKKI<sup>36</sup> (RUN) in (1) is mapped with the implicit PATH in the LCS of the verb *juoksuttaa* ‘make s.o. run’ (i.e. in zone 1 of the matrix structure), whereas the temporal ORadj TUNTI (HOUR) in connection with *jonotuttaa* ‘make s.o. queue’ is a structure-external element (analysed in (5)). The hierarchy of Maling is presented again in (10):

(10) SUBJ > OBJ > MEASURE > DUR > FREQ

<sup>36</sup> It should be noted here that the word *lenkki* is not an absolutely clear ‘measure’ (in the same sense as for instance a mile would be in *Matti juoksuttaa Pekalla mailin* ‘Matti makes Pekka run a mile-acc’) but a somewhat different object-like phenomenon. In addition to the circle-formed ‘path’, it encodes a type of training activity with the relative length of the route. Neither the length nor the (competitive) achievement are the focus in a typical expression with *lenkki*.

### 3.4 Towards a prototype-constructional approach

After the syntactic and conceptual analysis of different types of CSDs, let us reconsider the discussion of the criteria used to define the curative causative derivatives in chapter 1. Recall the discussion in section (1.2) about the standpoints within Fennistics, according to which ‘curativeness’ is a lexical property of the verb. In the following discussion, I describe the two main definitions of curatives using the present methodology as a tool. I call the approach of Hakulinen & Karlsson (1979) and ISK (2004) here the ‘morphosyntactic view’, and the approach of Kytömäki (1978, 1989) the ‘morphosyntactic-semantic view’. As a summary of the discussion in this chapter and a further option, I propose an alternative approach as the ‘prototype-constructional view’.

1. **The morphosyntactic view** states that curatives are causatives derived from transitive root verbs governing an adjunct (the SAR) marked with the adessive case. We can describe the morphosyntactic approach using the present methodology as follows (since the SAD is the common element in all three views, I do not mark it in the analyses below):

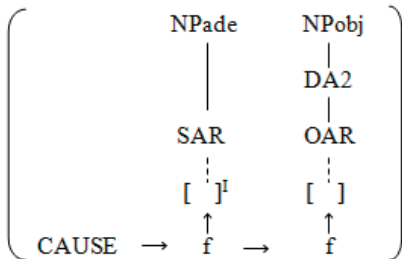

2. **The morphosyntactico-semantic view** states that curatives are derived from roots denoting activity, regardless of whether they are transitive or intransitive. These verbs’ argument structure involves an animate causer and an animate performer (the SAR) of the root verb activity. The SAR is expressed in syntax either as an adessive adjunct or the object of the sentence. I interpret the active performer-argument of the morphosyntactico-semantic approach as the actor (AC) in the sense of Jackendoff (1990) and Nikanne (1990); the social nature of the causation is described in the social semantic field. Note that the angled brackets < > around the implicitness index I represent the optionality of the notion in question (the SARobj is not an implicit argument); the curled brackets { } around the NPs stand for the mutually exclusive relation to the different positions.

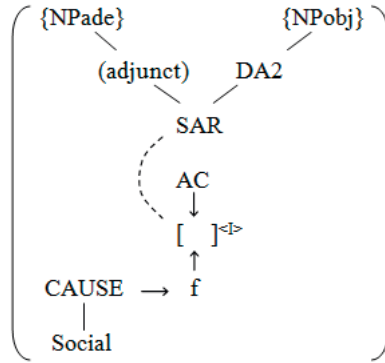

The crucial aspect of the approaches above would seem to be the realization of the SAR in syntax (plus its semantic interpretation in (2)). However, this study points to a more complex nature of CSDs. The CSD prototype structures have been shown to function as abstract patterns and an integrative factor for the different manifestations of CSD sentences. I argue that it is not useful to unite CSDs under a banner based on a single curative sentence type. In order to describe CSDs with a lower degree of generalisation, I divide the analyses into two main descriptions. The prototype-constructional view of the linking regularities of CSDs is presented in (3a-b). This is also a reanalysis of the prototype structures presented in 2.4.2, taking into consideration the results of the study in this chapter.

### 3. Prototype-constructional view

a) Adessive adjunct-actor prototype **PT1** (prototype 1):

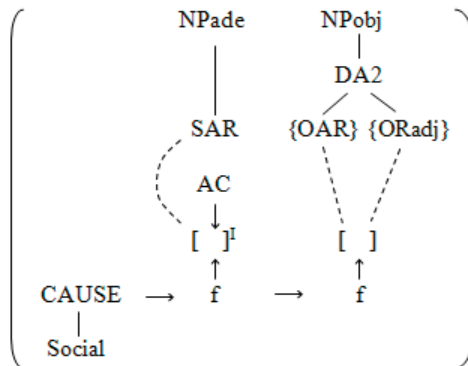



b) Objective actor prototype **PT2** (prototype 2):

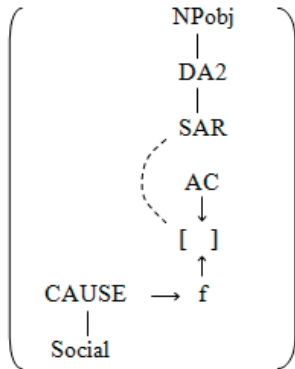

For a more specific analysis, the descriptions of PT1 and PT2 can be divided into two alternative subanalyses, based on the SAR linking relations to the different types of functions. The simple *f* in the *f*-chain of PT1 and PT2 stands for a function of an unspecified zone; the zones of these functions are specified in the subprototypes. Hence structure PT1.1 reflects the SAR linking to zone 3 i.e. to the 'cause'-function. The structure PT1.2 describes the SAR linking to zone 2, the theme argument. In both cases, the argument linked to the SAR is an implicit adessive adjunct. The sentences (2) in section 3.3.1 and (1) in 3.3.3 are examples of the PT1.1 and PT1.2 structures respectively.

**PT1.1:** Adessive adjunct prototype of double causative LCS

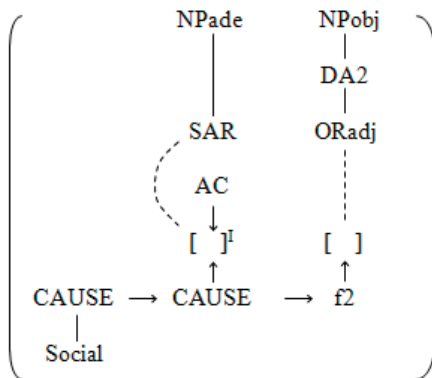

**PT1.2:** Adessive adjunct prototype of single causative LCS

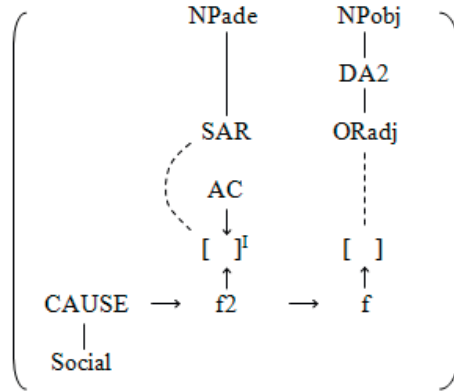

As substructures of PT1, PT1.1 and PT1.2 differ in the number of causations and mediating of the DA2 in the linking system, and the PT2 may occur with either one or two causations. The subprototypes of PT2 are analysed below; these can be compared to the examples (4) in 3.3.1 and (2) in 3.3.3.

**PT2.1:** Objective actor prototype of double causative LCS

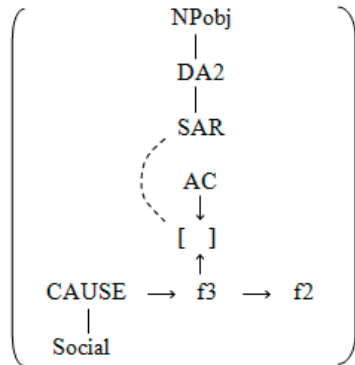

**PT2.2:** Objective actor prototype of single causative LCS

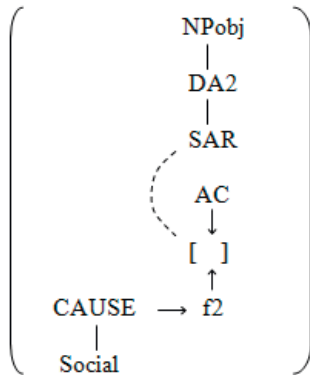

The two major structural patterns of CSDs are thus PT1 and PT2, reflecting the realization of the SAR as the adessive adjunct or as the object, respectively. The changes in relation to the first outline of the prototypes in section 2.4.2 are based on the more specific analysis in sections 3.3.1-3.3.3, indicating that these linking relations are not fixed to the number of causations in a CSD structure. In other words, this means that in contrast to the preliminary prototype account presented in section 2.4.2, the number of causations is no longer fixed by prototype 1 (PT1) and prototype 2 (PT2). PT1 is thus not the prototype of double-causative and PT2 single-causative derivatives. The double-causative prototype as defined in 2.4.2 corresponds here to the subtype PT.1.1 structure and the single-causative prototype to the PT2.2 structure. We will return to the causation-based prototype structures in connection with the action tier and temporal tier analysis in chapter 5.

The PT1 and PT2 structures represent different types of conditions; the prototypes instantiate models comparable to individual occurrences of CSDs and the causative structures these might occur within. Given the argumentation in this chapter, curativeness as such is not a lexical or transformational property. The structure PT1.1 reflects the morphosyntactic view: it represents the core of curativeness, the double causative CSD structure with the SAR expressed as the adessive adjunct. As we saw in connection with low transitivity CSDs (see (9a) in section 3.3.3), the adessive actor-adjunct structure is not restricted to double causative CSDs only; the SAR is not necessarily linked to a zone 3 function. The adessive adjunct SAR assignment can thus function more broadly than lexicon-based transitivity; the prototypical PT1.1 template licenses an object and the SAR can be expressed in the adessive case in syntax.

The objective actor prototype in (b), PT2, is here categorized as a separate CSD structure reflecting the observation of Kytömäki that a SAR with the role of active performer can also occur as an object in syntax; in present

terminology this means that the SAR can be linked to the DA2 position. This structure is thus comparable with the NPobj-SAR analysis of the morphosyntactico-semantic view (see above). Note that the SAR in PT2 is not implicit.

In a comparison of the structures presented above, it is noticeable that a specific part of the PT1 and PT2 structures is shared between all prototypes (see (a) and (b)). Let us call this shared part of the CSD prototypes a PT:

c) Core of CSD prototypes (PT):

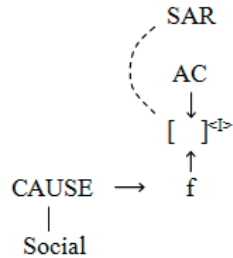

As I see it, the prototype-based approach may explain the indeterminacy of the criteria for curative derivatives – the heterogeneity regarding the root verbs being able to adjust the prototypes (and also constructions, which will be the topic of chapter 6 in particular) blurs the propounded limitations of a lexical class of CSDs. It is worth mentioning that not only prototype 1 but also prototype 2 affects the behaviour of CSDs in terms of the patterns they may occur in. As analysis in this chapter has shown, a CSD verb may adjust to more than one prototype structure. This phenomenon will also be seen in the analysis of the other CSDs in this study. The discussion in chapters 5 and 6 will reveal further restrictions that these structures may obtain. The prototype-constructional view is even included in these restricted structures; the synthesis of this approach is discussed in chapter 7. It is not precluded that the prototype patterns PT1.1 and PT1.2 may even break up into further, more exact structures. These can be seen as related CSD structures or subprototypes. We will see further variations of both the PT1 and PT2 structures in chapters 5 and 6. The next section provides an example of how a CSD may adapt different argument structures and linking configurations by altering the prototype patterns.

### 3.5 Diversity of argument structure: the case of *leikittää* 'make s.o. play'

The goal of this section is to outline the fact that prototype structures do not completely explain the behaviour of CSDs. From the point of view of the linking configuration, CSDs derived from verbs that fall within the middle area of the transitivity scale (identified as medium transitivity verbs in this chapter) raise intriguing questions. As the discussion of the language instinct test in section 3.1.4 showed, the medium transitivity verb *syötättää* 'make s.o. eat' received the highest values of standard deviation, and argument structure variations in the test responses were large. These verbs seem to be particularly context-dependent and adaptable to different sentential surroundings.

As an example of the argument structure variations of which these flexible verbs can be used as evidence, in this section I analyse the argument structure and use of an ordinary medium transitivity CSD *leikkiä* 'to play'. This verb expresses activity and occurs, according to Pajunen (2001: 164), with or without an object, focusing either on the activity itself or on the object of the activity. My focus is on the relationship between the two arguments of this verb in particular: how does the SAR and the inherent instrument, game or playing in the semantics of *leikkiä* affect the LCS of the derived causative *leikittää* 'make s.o. play'? I examine the lexical and syntactic flexibility of *leikittää* by means of the linking system; the focus is thus on linking between the morphorole and DA systems and the conceptual structure. In order to illustrate the argument structure variations of *leikittää*, I present examples taken from language use. I have underlined the instrument or 'play' arguments in (1a-h).

- (1a) *Pienoiskoti leikittää kaikenikäisiä ihmisiä.*  
playhouse-nom play-cause-3sg all-aged-pl-part person-pl-part  
'The playhouse gets people of all ages playing.'  
(<http://www.avotakka.fi/lehti/aiemmat/article114466-1.html>, 7.3.2005)
- (1b) *Vanhempainyhdistys leikittää perinneleikkejä koulun pihalla 15.9.*  
parent's association play-cause-3sg traditional.play-pl-part school-gen  
yard-ade 15.9.  
'The parents association will be having [the kids] play traditional games  
in the school yard on 15 September.'  
(<http://www2.kotka.fi/metsolankoulu/syyskausi%202004.htm>, 7.3.2005)
- (1c) *Lisäksi pojat leikittävät lapsia hauskoilla laululeikeillä*  
in addition boy-pl play-caus-3pl kid-pl-part risible-pl-ade carol.play-pl-  
ade  
'In addition, the boys will make kids play funny carol games.'  
(<http://www.jari-taikuri.com/muut/index.htm>, 7.3.2005)

- (1d) */.../ kansanmusiikin opiskelija Ninni Volanen leikittää ja laulattaa lapsia ja aikuisia kalevalaisin sävelin*  
folk music-gen student-nom Ninni Volanen play-cause-3sg and sing-cause-3sg child-pl-part and adult-pl-part kalevala-pl-ins tune-pl-ins  
'/.../ folk music student Ninni Volanen makes both children and adults play and sing along to Kalevala tunes.'  
(<http://agricola.utu.fi/nyt/tapahtuu/ilmot/2329.html>, 7.3.2005)
- (1e) *Viimeisen heiton sijaan koiralle annetaan puru ohjaajalla olevasta patukasta ja koiraa leikitetään äänellä kehuen ja mukana riemuiten*  
'Instead of throwing the toy for the last time, instructor can let the dog bite the bar, and the dog is given permission to play by praising the dog and being cheerful.'  
(<http://koti.mbnet.fi/tuulen/saalisvietti.htm>, 7.3.2005)
- (1f) *Lasta voi leikittää, hypittää, kutittaa ja taputtaa lorun mukana*  
child-part can play-cause-inf, jump-cause-inf, tickle-inf and clap-inf nursery rhyme-gen with  
'The child can be made to play, jump, tickle and clap along using the nursery rhyme.'  
([http://www.nettineuvo.fi/nettineuvo/fi/02\\_Lapset/02\\_Lapsen\\_kehitys/03\\_Puheen\\_kehitys/index.jsp](http://www.nettineuvo.fi/nettineuvo/fi/02_Lapset/02_Lapsen_kehitys/03_Puheen_kehitys/index.jsp), 7.3.2005)
- (1g) *Sitten leikitin sitä hetken pallon kanssa ja lähdin kotiin*  
then play-cause-past-1sg he-part while-gen ball-gen with and go-past-1sg home-ill  
'Then I had him play with the ball for a while and we went home.'  
([http://www.emmintalli.linja.org/p\\_monni.html](http://www.emmintalli.linja.org/p_monni.html), 7.3.2005)
- (1h) *Tommi Laine liikuntavirastosta leikitti ja luistelutti lapsia musiikin kera*  
Tommi Laine physical.education.office play-cause-past-3sg and skate-cause-past-3sg music-gen with  
'Tommi Laine, from the office of physical education, made the kids play and skate along to the music.'  
([http://www.ouka.fi/lahidemokratia/suuralueiden\\_muistiot/muistiot/HOYHTYA/2006/yhteistyoryhma060406.htm](http://www.ouka.fi/lahidemokratia/suuralueiden_muistiot/muistiot/HOYHTYA/2006/yhteistyoryhma060406.htm), 7.3.2005)

On the basis of examples (1a-i) we can conclude that the instrument or the game can occur in different syntactic functions: subject (1a), object (1b), adverbial NP (1c-e) and PP (1f-h). The case of the adverbial NP is typically adessive (1c) or instructive (1d). The playing can also be expressed by means of infinitive constructions, as for instance the e-infinitive instructive in (1e). The postpositions *mukana*, *kanssa* and *kera* in (1g-i) correspond roughly to the English preposition 'with' and all indicate an instrumental or comitative role.

On a closer look, it appears that these examples basically reflect three types of argument structures. The alternations of the argument structure of *leikittää* are encapsulated in structures (2-4). Example (2) expresses the SAD (MATTI) and the SAR (PEKKA) in the partitive case, while the OAR (PLAY) remains implicit. In (3), the SAD (MATTI) and the OAR (ROUNDERS) is expressed; the player, the SAR, is not explicitly given. Note the DA-linking in these first two sentences – the DA1 in both cases is the SAD, but the DA2 is linked to the SAR in (2) and to the OAR in (3). There is also a third variation of the argument structure of *leikittää*; sentence (4) differs from the previous ones in that the OAR (PLAY) is linked to the DA1 position in the causation zone. The SAR here is linked to the DA2.

(2) *Matti leikittää Pekkaa*

Matti play-cause-pres-3sg Pekka-part  
 ‘Matti makes Pekka play.’

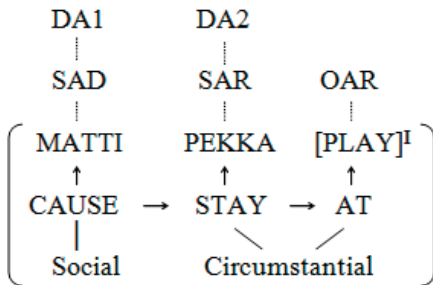

(3) *Matti leikittää poltopalloa*

Matti play-cause-pres-3sg rounders-part  
 ‘Matti has [s.o.] play rounders.’

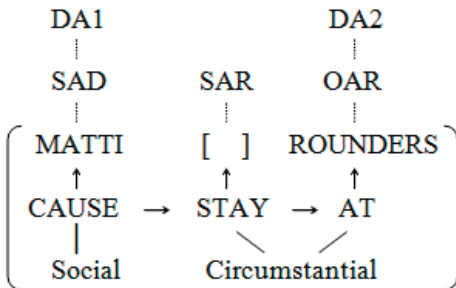

- (4) *Polttopallo leikittää lapsia*  
 rounders play-cause-pres-3sg children-part  
 ‘Rounders makes children play.’

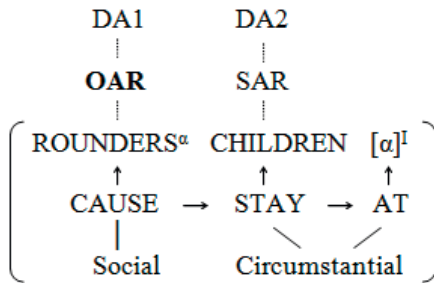

Basically, the structure in (2) corresponds to the prototype pattern PT2.1, defined in the previous section, and the structure in (3) to PT1.2. The morphorole and direct argument linking shows that the logical object (DA2) can be mapped with either the OAR or the SAR, as was also seen in connection with the CSDs in section 3.3. The substantial linking formation regarding the morphorole linking is especially visible when it comes to the OAR: the OAR can be linked to the theme, goal or even the causer argument (OAR-DA1). The linking configuration of (4), where the OAR assigns the position of the DA1, is exceptional in respect of the linking system of CSDs as stated in section 3.4. This phenomenon is also examined in connection with the verbs *haetuttaa* ‘make s.o. fetch’ and *etsityttää* ‘make s.o. search’ in section 5.3.4; it appears that there are more verbs that place the OAR in the DA1 position, although this phenomenon does not seem to be very common. Exceptional DA1 linking is discussed in more detail in the construction chapter.



### 3.6 Conclusions on linking regularities and syntax-semantic interface of CSDs

There are basically two main conclusions we can draw from the analysis in this chapter. Firstly, the status of CSD prototype structures as patterns behind different types of CSDs as defined in section 2.4.2 was principally supported. The focus was on the syntactic behaviour of different types of CSDs and the linking relations between the syntactic and conceptual structures of the selected verbs and sentence types in particular. As a result, the prototype structures were specified further from the preliminary assumption as presented in section 2.4.2. The elaboration of the prototype-constructional view in section 3.4 takes the results of the analysis into consideration by redefining the prototypes and their substructures and, in addition, the shared structural core. The two upper prototypes were defined as the adessive adjunct prototype (prototype 1) and the objective actor prototype (prototype 2), with the difference from the preliminary prototypes being that prototype 1 is no longer assumed to be a double-causative nor prototype 2 a single-causative structure. It appeared that both the adessive SAR adjunct and objective SAR of CSDs can be mapped to zone 3 and zone 2 arguments.

The main conclusion regarding the prototypes is that they do not function as lexical dividers of CSDs into prototype 1 and prototype 2 verbs, but as underlying linking patterns explaining the sentential behaviour of CSDs. Both the language instinct test results (see 3.1.4) and the linking system analysis (see 3.3) indicated that most of the tested verbs were able to change prototype. In particular, the intermediate argument linking arrangement i.e. the DA and morphorole linking system was found to have an impact on the prototype with which the argument structure in question correlates. The DA and morphorole linking appeared to be central in all of the verb groups analysed in this chapter in terms of how the derivatives are associated with the prototype patterns.

The prototypes were found to serve as explanatory models for the results of the language instinct test; the language users strove to interpret the sentence alternations according to the prototype patterns. By means of the prototype structures, even the less typical uses of CSDs can be expounded and other structures (for instance locative SAR interpretations) distinguished. Section 3.3 focused on the conceptual-syntactic interface of the tested verbs. It appeared that high transitivity verbs adapt the prototype 1 structure, but also that the prototype 2 linking configuration<sup>37</sup> is possible for these

---

<sup>37</sup> I consider the verb *teettää* ‘make s.o. do’, analysed in 3.3.1, exceptional – prototype 2 does not function with this verb because it does not encode any particular activity, but obtains its meaning in connection with a theme argument. Therefore, it cannot be interpreted in a generic sense without an overt object of activity. This verb shows that a CSD does not necessarily adapt more than one prototype structure, which emphasises the individual nature of these derivatives.

derivatives. Medium transitivity verbs proved to be particularly flexible regarding adjustment to prototype patterns. Low transitivity verbs are able to adapt the prototype 2 linking formation in addition to the prototype 1 structure. Thus both the language instinct test results and the conceptual analysis combined with the linking formation study show that we cannot automatically divide CSDs into prototype 1 and prototype 2 verbs; the linking characteristic with each verb proves to embody a flexibility aspect in order to adjust the syntactic alternations. Principally, the studied CSD verbs divided into transitivity-based groups are able to adapt both prototypes.

The linking patterns presented throughout the subsections of 3.3 in connection with CSDs derived from different roots can be generalised as follows: regardless of variations in the thematic tier such as the number of causations, the OAR, SAR and ORadj can be assigned as the DA2. It also appeared that in order to be a clear sentence, the prototype 1 structure (the a-structure in the syntactic test) favours a resultative object. This could explain the low acceptance of the Oradj structure analysed in connection with the low transitivity verb *jonotuttaa* ‘make s.o. queue’ (see example (5) in 3.3.3). Nevertheless, CSD prototypes also seem to explain less typical uses of CSDs, since the language users’ interpretation and comprehension of the CSD sentences for the most part mirrored the prototype structures. As with deviations from the prototype structure like the ORadj linking pattern in connection with low transitivity CSDs, the linking system of the prototype structures plays an essential role – it is in the background of the prototype structure that the aberration is visible.

The second main inference of this chapter is that the CSDs that were the focus of this chapter went a long way to prove the idiosyncrasy that exists even within the same group (as for instance with high and low transitivity verbs). A (high transitivity) CSD can even appear in an intransitive sentence pattern, as the sentence *Matti ompeluttaa Pekalla* [SAD, SARade] showed (see 3.3.1). Sentential structure variations raise a question about focus – in the case of the medium transitivity verb group in particular, the flexibility of the argument structure appears to be a transition of focus from the activity of the SAR to the processes directed towards the OAR.

These aspects suggest that transitivity as a category is not a well-functioning phenomenon in the explanation of the argument structure variety of CSDs. The arguments in this chapter have shown that transitivity is not an absolute concept that can be used to define a derivation class comprising verbs as heterogeneous as CSDs. The core argument regarding transitivity, the syntactic object, functions as an open slot into which semantically different types of linguistic elements can be inserted. In other words, there are a number of argument structures to which different types of verbs can relate. The verb analysis in this chapter indicates that instead of an explanation of CSDs as more or less ‘static’ verb groups with the curative

construction as a lexical property of CSDs, the adessive adjunct structure can be seen as one of the patterns in which these verbs are able to occur.

This perspective supports the constructional approach to a near-standing phenomenon, the Finnish emotive causatives (*tunnekausatiivit*). Siirainen (2001: 46-57) argues that causative emotive verbs are best described by their ability to occur in different constructions, which are not purely lexical properties of these verbs. She distinguishes between two constructions in the sense of the special form-meaning constellations in which Finnish causative emotive verbs are used: the transitive construction (1) and the emotive transitive construction (2). The transitive construction is characterised by the SVO word order, where the stimulus-subject is animate and intentional participant (an agent) followed by the experiencer-object. The emotive transitive construction is characterized by the reversed word order (O)V(S).

(1) *Pekka järkyttää opettajaa tempullaan.*

Pekka upset-pres-3sg teacher-part trick-ade-px3sg  
'Pekka upset the teacher with his prank.'

(2) *Opettajaa järkytti Pekan temppu.*

Teacher-part upset-past-3sg Pekka-gen trick-nom  
'The teacher was upset by Pekka's prank.'

After the conceptual analysis of the CSDs, we can conclude that the hierarchy of the morphoroles competing for the DA2 position as proposed in 3.2 has basically been confirmed. However, the status of the morphoroles regarding mapping to the conceptual level is somewhat different than in relation to the DA level: the SAR has a higher position in the thematic tier, whereas the OAR has it in the DA2 linking hierarchy. The morphorole linking to the conceptual arguments is ordered as SAD–SAR–OAR from left to right in the thematic function chain. The SAR is linked next to the SAD in the thematic tier, but the OAR still has preference when it comes to DA2 assignment. Because the SAD is typically the left-most thematic argument in the conceptual structure of a CSD, it is assigned DA1 status.

However, there are also deviant morphorole linking configurations in relation to the linking hierarchy. As the argument structure analysis of *leikittää* 'make s.o. play' in section 3.5 proved, the SAD can drop its DA1 status to the OAR (recall the analysis of sentence (4) in this section). This suggests that the default linking configurations as redefined in section 3.4 can be useful in defining potential constructional structures; the exceptional linking configuration is revealed in comparison to the regular system. Exceptional linking is the topic of section 5.3.4 in particular in connection with the verbs *haetuttaa* 'make s.o. fetch' and *etsityttää* 'make s.o. seek'.

There are certain consequences related to the discussion of the linking arrangement of different types of CSDs. One is that the SAR is expressed in

---

object cases when the OAR or ORadj is not expressed in the syntax. This is also the case with the high transitivity CSD group, not just with verbs in the middle and low transitivity groups. Another tendency reflecting the characteristics of SAR assignment is that in the case of high transitives, the SAR (the actor) does not have to be expressed syntactically, whereas in the case of low transitive verbs, the SAR should be visible in the syntax (which is why the structure [SAD, ORadj] is not a clear sentence for instance in connection with the low transitivity CSD *jonotuttaa* ‘make s.o. queue’ in #*Matti jonotuttaa tunnin*). The SAR characteristic can be generalised as follows:

- a) CSDs with both transitive and intransitive root verbs are able to assign the adessive adjunct, which has the role of the performer of the action denoted by the root verb; this explains the SAR linking to the thematic tier – the SARade occurs in zone 2 in addition to zone 3 (the agentive features of the main arguments and their treatment within conceptual semantics is examined in chapter 4).
- b) Regardless of the syntactic appearance, the SAR is semantically encoded as a participant in the situation denoted by the root verb.

Finally, one outcome of the analysis in sections 3.3.1-3.3.3 especially is that the linking of adverbials of amount (analysed as the ORadj) from conceptual structure to syntax has been clarified to some extent.

## 4 Causation, agentivity and temporal relations

The discussion in this chapter is devoted to two areas closely related to the notion of causation. In an analysis of causation, especially with human participants involved, the aspects usually related to agentivity become significant. The agent properties of the main CSD participants have not been discussed in detail thus far; this is the topic of the discussion in section 4.1. A CSD also represents a complex phenomenon in terms of the temporal relations involved in the proposition. The temporal structure of the CSDs is also a topic of this chapter. The analysis in 4.3 follows the idea that the causal structure of an LCS and its temporal structure exhibit a mutually influencing relation (Jackendoff 1990, Nikanne 1990, 1997b, Pörn 2004). Primarily, my aim is to examine the effect of the temporal structure on the CSD proposition in respect of the prototype structures defined in sections 2.4.2 and 3.4. The main questions of this topic are: how does a causation event relate temporally to another causation or to the transition of theme? How does the structure of the temporal tier interact with other parts of the LCS of CSDs? Another subject is the correlation between the agentive participants and temporal relations. I expect the temporal structure analysis to explicate, *inter alia*, the ‘non-participation criterion’ as presented in section 1.2 i.e. the question of the participation of the SAD in the root verb activity. Thus, analysis of the time structure of CSDs also involves aspects of activity like variations in the caused activity in relation to different participants (an example will be the verb *pyöräilyttää* ‘make s.o. cycle’ in 4.3.4). What do the temporal relations reveal about the nature of causation in complex CSD structures? How does the time order of a constructional structure correspond to the causal representation? A parenthetical but relevant inquiry (from the point of view of causal relationships) including the temporal analysis of section 4.3.5 is related to CSDs within larger causative constructions i.e. in connection with a causative (subordinate) adjunct.

### 4.1 Activity and dominance

Notions of affectedness, activity and dominance within conceptual semantics are mainly treated in the action tier. The action tier relations in conceptual semantics are separated from the thematic tier roles, as briefly discussed in section 2.2.1. The division of semantic roles into two levels can be traced back to Foley and van Valin (1984), who treat the actor and undergoer as ‘macroroles’ in respect of ordinary semantic roles (the relations corresponding to Gruber’s (1965) thematic relations or Fillmore’s (1968) case roles). In their characterization of actor and undergoer, the former

represents the participant that performs, effects, instigates or controls the situation denoted by the predicate, and the latter is the argument that does not perform, initiate or control any situation but is rather affected by it in some way. No direct connection for instance between actor and syntactic subject is assumed (see Foley and van Valin (1984: 29). Analogically, Jackendoff (1990) argues that the conceptual roles are divided into two tiers: the thematic tier deals with motion and location, and the action tier deals with actor-patient relations. The relation between the predicate and its argument can thus be described via two positions, one in the thematic tier and the other in the action tier.

The focus of this section is on the aspects of dominance manifested in the action tier relations of CSDs. Since these derivatives carry information about human interaction joined with causation, they enable us to study the encoding of social relations in language. The inquiries being made in this section is: what does analysis of activity and dominance add to conceptual information? What is the role of the action tier and how does it contribute to the semantics of CSDs? In the tiernet model, action tier roles are not assumed to play any role in argument linking; action tier relations are not seen as necessary lexical information on verbs (see Nikanne 1995). What are the regularities of CSD argument-mapping in respect to the action tier and thematic tier? How are arguments bearing action roles linked to morphoroles? I will examine the consequences of the action tier formation of CSD prototypes as defined in section 2.4.2. The agentive properties of the main arguments in different syntactic and thematic positions will also be considered. As the conceptual structure analysis of CSDs in the previous chapter (see 3.3.1-3.3.3) showed, the SAR can be linked to the causer argument or to the theme argument. As such, the consequences of the different linking relations to the executer of the action will be discussed in sections 4.1.2-4.2. I will begin with a presentation of the action tier structure in section 4.1.1.

#### **4.1.1 Structure of the action tier**

In this section, I concentrate specifically on the formation of the action tier. As outlined in 2.2.1, the action tier of an LCS operates with two optional action tier roles, actor and undergoer, assigned by the functions AC and UN, forming an act-chain. These roles, according to Nikanne's (1995) analysis, are linked to the thematic tier, following principles that are to some extent freer than thematic role assignment: the role actor is always assigned to the left-most thematic tier argument of the LCS, while the role undergoer can in principle be assigned to any available argument in the LCS. In other words, the relation between thematic and action tier functions is not assumed to be one-to-one. For this reason, stipulation of the action tier roles in the lexical

entries of the verbs is not necessary; for the simplest possible description, only an exceptional action tier linking relation should be expressed.

In addition to the rule that the actor is assigned to the argument linked to the function with the greatest scope in the f-chain, there are the following principles that govern the assignment of action roles (Nikanne 1995: 10, 1998a):

- (1) a. No actors in zone 1 (i.e. no actors are locations, goals, sources or routes)
- b. The same argument cannot be selected by more than one AC.
- c. The actor must cs-command the undergoer selected by the same act-chain.

The notion ‘cs-command’ stands for the relation between arguments in the same f-chain where the scope of an argument selected by a function reaches over a complement of another function (about binding relations and conceptual structure, see Jackendoff 1992b; Culicover and Jackendoff 1995). According to principle (1a), the assignment of the actor role is to some extent restricted by the number of zones; an actor can, in the thematic tier, be assigned to an agent or a theme argument. The principle in (1c) has consequences for the order of the act-chain: the undergoer must be to the right of the actor selected by the same f-chain.

Another aspect is that act-functions are optional – there can only be one of them in the act-chain, or a sentence can lack an action tier altogether. Action tier functions thus have a supplying role in respect to the f-chain functions: they select arguments already selected by the f-chain (Jackendoff 1990 and Nikanne 1995). Consider the following sentences with different action tier structures:

- (2) *Jane dances.* - [[AC],[ ]]  
       *Jane dies.* - [[ ],[UN]]  
       *Jane knew the answer.* - [[ ],[ ]]

In order to separate the active and passive participants, Jackendoff (1990: 125-126) uses a test with the general making verb ‘to do’ and the verb ‘to happen’. The way to judge whether an NP can be assigned the role actor or undergoer is presented in (3):

- (3) { *What happened* } to Y was...  
       { *What X did* }

The test consists of three sentences, where the subject of ‘do’ is always an actor (X); the object of ‘do to’ is an undergoer (Y); and the object of ‘happen to’ is always an undergoer (Y). The test sentences are the following:

- (4) a. What X does is S.  
 b. What X does to Y is S.  
 c. What happened to Y is S.

As an alternative test for Finnish verbs, Nikanne (see 1995: 6-8) uses the verb *tehdä* ‘to do, make’, expressing an unspecified action performed by the subject, and *tapahtua* ‘to happen’. Both verbs take an allative complement which corresponds to the English ‘to’-complement; this allative complement is an undergoer:

- (5) a. Se mitä X tekee on S  
 it what X does is S  
 ‘What X does is S.’  
 b. Se mitä X tekee Y:lle on S  
 it what X does to Y-all is S  
 ‘What X does to Y is S.’  
 c. Se mitä Y:lle tapahtuu on S  
 it what Y-all happens is S  
 ‘What happens to Y is S.’

Consider the sentence *Ann siivoaa huoneen* ‘Ann cleans the room’ in (6) and the action role test in (7):

- (6) *Ann siivoaa huoneen.*  
 Ann clean-pres-3sg room-acc  
 ‘Ann cleans the room.’
- (7) a. Se mitä Ann tekee on että hän siivoaa huoneen.      Ann = actor  
 it what Ann does is clean room  
 ‘What Ann does is clean the room.’  
 b. Se mitä Ann tekee huoneelle on että hän siivoaa sen.      Ann = actor;  
 it what Ann does to room-all is that she clean it      room = undergoer  
 ‘What Ann does to the room is that she cleans it.’  
 c. Se mitä huoneelle tapahtuu on että Ann siivoaa sen.      room = undergoer  
 it what room-all happens is that Ann clean it  
 ‘What happens to the room is that Ann cleans it.’

The action tier functions of the sentence (6) *Ann siivoaa huoneen* are marked in the conceptual structure as in (8):



(8)

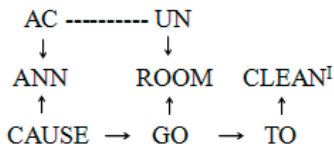

The conceptual semantics theory thus treats the notions of theme and patient on different levels of description. While the definition of the theme is “a thing in motion or being located”, the action tier role undergoer corresponds to the traditional notion of the patient as “the affected entity”. The role of undergoer can be analysed further using the subroles ‘beneficiary’ (UN+) and ‘malefactive’ (UN-) according to the effect the activity of the actor has on the undergoer. The effect is usually inferred from the contextual information, but in some cases the benefit or suffering are lexically encoded. Nikanne (2002) considers the action tier roles UN+ of verbs like ‘to help’ or UN- of ‘to pester’ as lexicalised information; thus, the action tier may have lexical significance. The structure of the action tier is formalized in Nikanne (1995:8) as in (9). The angled brackets in (9) indicate optionality and the slash stands for the possibility of alternatives according to the effect of the dominance the actor has over the undergoer.

(9) &lt;AC&gt; -- &lt;UN &lt;+/-&gt;&gt;

#### 4.1.2 Action tier configurations of CSDs with causative vs. non-causative roots

What characterises the action tier of CSDs? What is the role of the action tier in the semantics of these verbs? Nikanne (1998a) argues that the role actor is significant in linking the conceptual structure to the lexicon in that for each actor there must be an LCS of a verb. Finnish causative derivatives are exceptional in this respect in that they incorporate two actors in their LCS. The explanation for this is that Finnish morphology allows for an embedded ‘functional complex’ or lexical structure of a lexical item, encoding the second actor in a causative LCS. Basically, this means that the lexical information of the causative suffix *-tta* includes the function AC (Nikanne 1998a). Consequently, there are two active participants (actors) and (at least) one passive participant i.e. an undergoer in the LCS of these causative verbs. The organization of action tiers is such that there is one action tier chain for the whole derivative and one chain for the root verb structure. This is described in (1): the structure indexed as *j* represents the LCS of the root verb and the structure indexed as *i* stands for the derivative. This suggests that the root verb maintains a relatively independent status within the derivative

structure. Note that the angled brackets indicating optionality around the second ‘cause’-function in (1) show that the description covers CSDs derived from causative and non-causative root verbs.

(1) Organization of action tier of deverbal CSDs

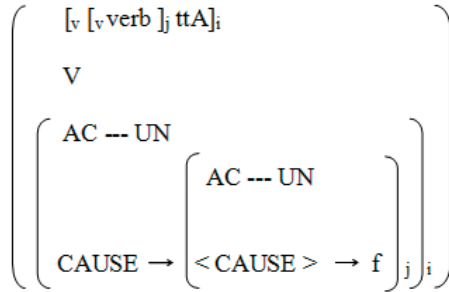

How do the action tier functions select their arguments in the conceptual structure of CSDs? Does the number of causations in the LCS of a CSD affect its action tier configuration? To examine the difference between derivatives with a causative vs. non-causative root verb, let us reanalyze the sentences used in section 2.4.2 to illustrate the prototype structures of a causative and non-causative CSD. The structures with their action tier functions are presented in (2) and (3):

(2) *Tom korjauttaa Matilla pyörän*

Tom repair-caus-pres-3sg Matti-ade bicycle-acc  
‘Tom makes Matti repair the bike.’

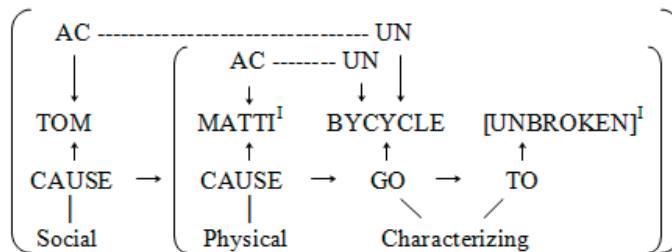

(3) *Tom marssittaa Matti kauppaan.*

Tom march-caus-pres-3sg Matti-acc shop-ill  
 ‘Tom makes Matti march to the shop.’

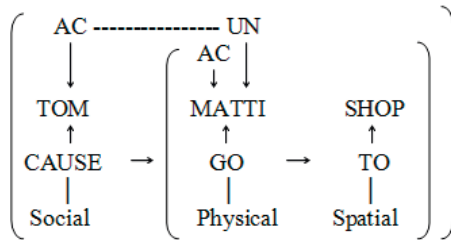

The difference between the structures in (2) and (3) lies not only in the formation of causation but also in the dominance relationship between the participants. On the action tier level, the second AC is assigned to the causer argument (2) or to the theme argument (3). Another issue is the selection of the undergoer. In the case of a CSD derived from a causative root verb like *korjata* ‘to repair’ (2), both act-chains contain a UN. The activity of both actors in connection with *korjata* can be said to be directed towards the theme argument (‘bicycle’), the undergoer for both actors. In (3), the CSD derived from the non-causative base verb *marssia* ‘to march’ has an undergoer only in the upper action tier. The role of undergoer is assigned to the argument, which is also assigned the role actor in the lower action tier; hence the SAR (Matti) of the non-causative root verb CSD *marssia* assigns two different action tier roles.

How significant is this difference? Can we say that CSDs have a lexicalized action tier? It was pointed out in section 4.1.1 that action tier roles are not considered to be necessary lexical information. Since the crucial characterization of CSDs is social causation, the effect of this is that there are prototypically two animate arguments participating in the CSD proposition. We may assume that the action tier has considerable value for prototype structures as presented in section 2.4.2. I return here to the causation-based prototype idea presented in section 2.4.2, though we saw that the number of causations is essentially non-determining for the prototype-based linking system (recall for instance the discussion on the prototype-constructional view in section 3.4). I will reanalyse the causation-based prototype structures of the CSDs by adding the (whole) action tier description to both structures. The CSD prototypes with their act-chains are presented in figures (4) and (5). The prototype structure in (4) thus corresponds to the double-causative prototype as presented in (3) in section (2.4.2) and to the reanalysed prototype structure **PT1.1** in section 3.4. The structure in (5) corresponds to the single-causative prototype in (4) in section 2.4.2 and to the **PT2.2** in section 3.4. Note that the consequence of the two causations in (4) to the linking relations in zone 1 is that the f2 argument is linked to the OAR –

DA2; the alternative linking option for prototype 1, the ORadj – Npobj, seems to require an LCS with only one causation (see the analysis of low transitivity verbs in 4.3.3). The single-causative prototype in (5) is thus thought to correspond to the structure [CAUSE → f2] of the PT2, not to [CAUSE → CAUSE], which is also a possible f-chain for the DA2-OAR linking formation.

(4) Double-causative CSD prototype

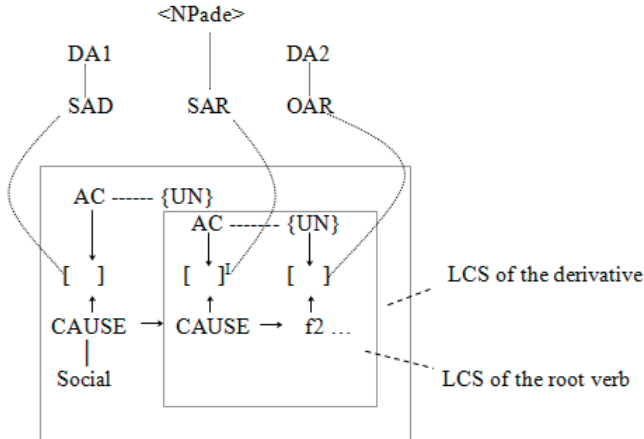

(5) Single-causative CSD prototype

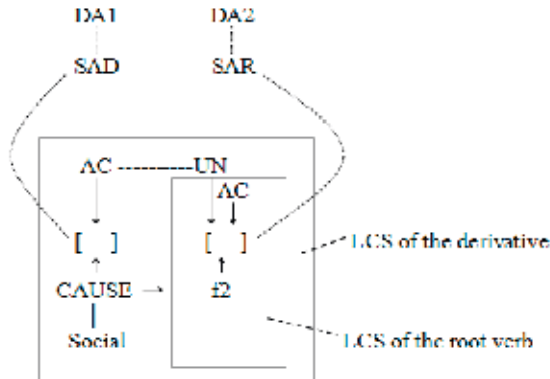

The prototype structures in (4) and (5) differ in their zone-based actor role assignment: in the case of the double-causative prototype, the AC of the lower act-chain is assigned to an argument in the causation zone, and in the case of the single-causative prototype, to an argument in the thematic zone. According to the prototype structures, we can formulate the regularities in argument-mapping between the LCS and the morpholexical level as follows:

the SAD is linked to the argument bearing the actor role in the upper act-chain and the SAR is linked to the argument bearing the actor role in the lower act-chain. The DA-linking differs from this order: the DA2 of the double-causative prototype is not linked to the actor argument of the lower act-chain but to an undergoer (mapped to the OAR). In the case of the single-causative prototype, the DA2 is linked to the actor argument (the SAR).

The assignment of the role undergoer in the case of the single-causative prototype shows that the upper act-chain undergoer is linked to the argument bearing the role actor in the lower act-chain. The activity of the lower actor is not directed at any other argument; this act-chain only includes an actor argument, linked to the SAR and the DA2. The selection of the role undergoer is more ambiguous in the case of the double-causative CSD structure, because there is more than one candidate for the upper act-chain UN, as well as for the lower act-chain. Therefore, I mark the possibility of different positions of the affected arguments using brackets {} around the UNs in structure (4), indicating the alternative UN-linking. Example (6) illustrates the complexity of the double-causative act-tier: the actor in the upper action tier, JANE, can be claimed to dominate at least two arguments, the second agent argument TIM and the goal argument HOUSE.

(6) *Jane maalauttaa Timillä talon*

Jane paint-caus-pres-3sg Tim-ade house-acc

‘Jane made/had Tim paint the house.’

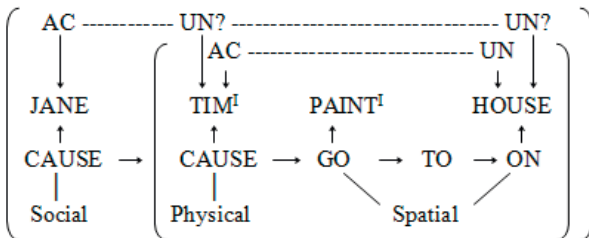

The action role test presented in 4.1.1 confirms that both arguments can prove to be suitable for the role of undergoer.

- (7) a. *Se mitä Jane tekee Timille on että hän maalauttaa hänellä talon.*  
 it what Jane does to Tim-all is that she paint-caus-3sg he-ade house  
 ‘What Jane does to Tim is that she has him paint the house.’  
 TIM = UN

- b. Se mitä Jane tekee talolle on että hän maalauttaa sen Timillä  
 it what Jane does to house-all is that she paint-caus-3sg it Tim-ade  
 ‘What Jane does to the house is that she has Tim paint it.’  
 HOUSE = UN
- c. Se mitä Timille tapahtuu on että Jane maalauttaa hänellä talon  
 it what Tim-all happens is that Jane paint-caus-3sg he-ade house  
 ‘What happens to Tim is that Jane has him paint the house.’  
 TIM = UN
- d. Se mitä talolle tapahtuu on että Jane maalauttaa sen Timilla  
 it what house-all happens is that Jane paint-caus-3sg it Tim-ade  
 ‘What happens to the house is that Jane has Tim paint it.’  
 HOUSE = UN

In (8), the upper act-tier undergoer can be assigned to the second agent or to the theme argument:

(8) *Jane teettää Timillä talon.*

Jane make-caus-pres-3sg Tim-ade house-acc  
 ‘Jane made/had Tim build the house.’

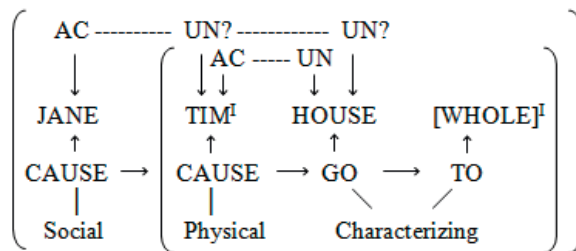

Examples (6) and (8) indicate that if there are several candidates for the role of undergoer, the actor can in principle relate relatively equally to more than one. I thus assume that both interpretations are possible; in actual cases it depends on the contextual focus as to which thematic argument is emphasised as the undergoer. The morpholexical argument selection of the upper tier undergoer in the case of the double causative prototype (see (4)) is presented in (9); the arrows with dotted line indicate the alternative mapping between the undergoer and the thematic arguments linked to the SAR and OAR.

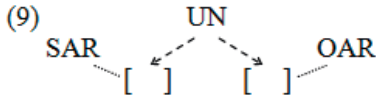

Following a more detailed examination of the causative structures and action tiers, the organization of CSD action tiers is reanalysed in structure (10):

(10) Organization of action tier of deverbal CSDs

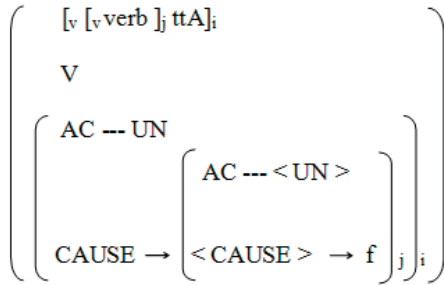

The action tier formation of CSDs raises further questions. How does the implicitness of an argument affect the assignment of an action tier function? As we saw above, an AC can be assigned to an implicit argument if it is expressed syntactically. Is there a hierarchy if there is more than one candidate for undergoer assignment? Does the selection depend on aspects other than focus? What are the implications of the single-causative prototype, where an argument already having an action tier role assigns a different role in another act-chain (see also (7a and 7c)) i.e. when the actor in the lower act-chain is selected as an undergoer for the lower act-chain? How does this differ from an argument with identical double roles (UN and UN)?

In the next section, the semantic properties of CSD actors are discussed in more detail. I expect this discussion to explain the division of agent-patient features between the levels of the LCS. The analysis of agentive properties may also shed light on the selection of the upper act-chain undergoer between SAR and OAR. However, the action tier also forms part of temporal and causal analysis. I will return to the question of the hierarchy of undergoer roles in section 5.2.6 below.

## 4.2 Agent features and their distribution between CSD arguments

Semantically, the actor(s) of a proposition are the key participants. The semantic particularity of CSDs is that the first animate causer argument (linked to the SAD) is typically the instigator and the second animate participant (linked to the SAR) is the performer of the situation denoted by the root verb. Both these participants thus display properties of the actor as defined by Foley and van Valin (1984), presented in 4.1. However, both the SAD and SAR arguments seem to acquire undergoer characteristics, since the SAD does not perform the activity and the SAR is typically socially affected by the SAD in order to perform the activity. Hence the agent-patient relations in a CSD proposition display a rather complex phenomenon. Consider some examples from language use illustrating the actors in CSD expressions. Note that all of the SAD referents represent an institutional actor (the police, the congregation, the police and the gymnastics club); the influence of the SAD varies from ordering to instructing.

(1a) *otattaa kiinni* [take-caus fastened] ‘make s.o. capture, catch’

*Suomen poliisilaitoksen olisi pitänyt otattaa tuo kiinni Thaimaalaisilla virkaveljillään.*

‘The Finnish police force should have **made** their colleagues in Thailand **catch** him.’

(<http://www.dvdplaza.fi/forums/showthread.php?t=37625>, 5.11.2005)

(1b) *keitättää* [cook-caus] ‘make s.o. cook’

*paistattaa* [bake-caus] ‘make s.o. bake’

*Seurakunta kahlaa rahoissa, keitättää kahvit ja paistattaa pullat ahkerilla naisilla*

‘The congregation is rolling in money and **has** hard-working women **make** coffee and **bake** buns.’

(<http://www.ruijan-kaiku.no/rk0202/ledere0202.html>, 26.11.2004)

(2a) *puhalluttaa* [blow-caus] ‘breathalyse; make s.o. blow’

*Poliisi puhalluttaa perjantaina ja lauantaina tavallista enemmän autoilijoita etenkin taajamissa ja niiden lähiteillä.*

‘The police **breathalyse** more drivers than usual on Friday and Saturday, especially in built-up areas and the areas around them.’

(<http://www.helsinginsanommat.fi/tuoreet/artikkeli/1076154623457>, 24.11.2005)



(2b) *notkistuttaa* [become flexible-caus] ‘make s.o. become flexible’

*IINA alkoi mm. notkistuttaa aerobicillä jääkiekkoilijoita ja jalkapalloilijoita*

‘The IINA gymnastics club started to **make** the ice hockey players and football players more **flexible** using aerobics, among other things.’

(<http://www.iina.fi/Seuran%20historiaa.htm>, 24.11.2005)

The discussion in this section focuses on the agentive properties of the actors linked to the SAD in comparison to the SAR actor. I elaborate the differences between the agent features of the SAR in connection with the double-causative and single causative CSD prototypes ((see (4) and (5) in section 4.1.2 respectively). I refer to the SAR of the double-causative prototype as the ‘**causer-SAR**’ and to the SAR of the single-causative prototype as the ‘**theme-SAR**’. Examples (1a-1b) present a CSD situation with a causer-SAR and examples (2a-2b) present a theme-SAR situation.

Dowty (1991: 571-575) treats the agent and patient as the thematic role types relevant to argument selection based on typological evidence. He argues that these roles represent prototype-based cluster concepts rather than discrete categories, and calls them the ‘Proto-Agent’ and ‘Proto-Patient’. Similar to Foley and van Valin’s, Jackendoff’s and Nikanne’s division of action roles vs. thematic roles on different levels, Dowty’s proto-roles are regarded as being independent in respect of classical thematic roles (the view on argument-linking differs, however, from the tiernet theory). To explain the ‘degree of membership’ in a role type of a participant role, Dowty proposes a list of semantic components characterizing the proto-role types. The properties of the prototypical agent are, according to Dowty (1991: 572), the following:

(3) Proto-Agent properties:

- a. volitional involvement in the event or state;
- b. sentience (and/or perception);
- c. causing an event or change of state in another participant;
- d. movement (relative to the position of another participant); and
- e. exists independently of the event named by the verb.

The prototypical agent is thus an intentional, conscious, volitional causer and the active participant. What do the proto-role properties reveal about the nature of CSD arguments? Are there differences between the causer-SAR and theme-SAR in terms of these properties? Is the SAD a stronger agent than the SAR? When adapting the properties of (3) to CSD actor-arguments, we obtain the following picture:

## (4) Proto-Agent features of CSD arguments:

	a	b	c	d	e
SAD	+	+	+	(-)	+
Causer-SAR	+	+	+	(+)	+
Theme-SAR	(-)	+	-	(+)	+

The SAD fills almost all of the proto-agent entailments presented in (3), with only one feature lacking. The SAD is typically volitionally and intentionally involved in the event (a); we can say that the SAD strives to realise the situation denoted by the root verb or to see it realised. The SAD is also a conscious actor (b), not only because it is an animate being, but sentient “with respect to the event denoted by the verb” (Dowty’s formulation). Also, the c-property corresponds to the SAD semantics, as it is the causer of the event encoded by the root verb. Dowty (1991: 573) states that causation is almost always accompanied by movement. This is not the case in SAD causation – the SAD does not typically participate in the activity denoted by the root verb, and it is not specified by a CSD whether the SAD moves or not. Thus, the d-property (movement) does not match the semantics of the SAD. The e-property, ‘independent existence’, is characteristic of the SAD, since it is not specified by the verb<sup>38</sup> and exists both before and after the event (i.e. it is not brought into being or destroyed by the event denoted by the verb).

How does the causer-SAR, the second actor of the double-causative CSD, adapt the proto-agent properties? Is the action the causer-SAR performs volitional? For instance, in the double-causative proposition *Tom korjauttaa Matilla pyörän* ‘Tom makes Matti repair the bike’, the SAD (Tom) intends to get the bike repaired by Matti, and we can infer that the SAR (Matti) also aims to perform the repairing activity. Obviously, the causer-SAR acts consciously, and this causes the event of the bike getting repaired. The causer-SAR exists independently of the event the verb denotes. The only ambiguous feature is the d-property, the movement – in the *korjauttaa* example, Matti does not necessarily move (or in the example (1b)), but there certainly are cases where the SAR moves (as in *Matti kuljetuttaa Pekalla paketin Helsinkiin* ‘Matti makes Pekka take the package to Helsinki’, see also example (1a)). Thus, the conclusion is that the causer-SAR may attain all of the Dowty proto-agent properties of (3), with the condition that the root verb denotes motion. Compared to an SAD which lacks the movement feature, the causer-SAR can even be regarded as more agentive than the SAD.

The properties of the theme-SAR can be analysed using the example *Tom marssittaa Mattin kauppaan* ‘Tom makes Matti march to the shop’. It is not apparent from the proposition if the action of the theme-SAR (Matti) is

<sup>38</sup>If for instance “agentive causer” is not counted as a specification.

volitional. The theme-SAR contains no causation property and lacks control over the situation; also, the volitionality property appears to be questionable. However, it is a sentient agent in respect to the event denoted by the root verb. The independent existence property is also present. The property of movement in turn is fulfilled at least if the root verb denotes motion. In the *marssittaa* example, the theme-SAR moves both in respect of the position of the SAD and of the goal ('shop'). It can be speculated that the d-feature i.e. movement of the second actor linked to the SAR and the SAD lacking this feature is a motivation for the accusation implication in connection with some CSDs derived from motion verbs (this phenomenon is discussed in more detail in 5.2). In conceptual semantics, movement is described in the thematic tier, not the action tier – motion *per se* is not seen as an agentive property. More precisely, the transition of theme belongs to the event described in zone 2-1. Therefore, the d-values in (4) are placed in parenthesis. The motion of the causer is not excluded; for instance, if the causing event shares its temporal structure with the caused event, the causer may be involved in the motion event (this is discussed in detail in section 4.3).

For the actors of a CSD proposition, there are two additional properties that are important in terms of the semantic content of the root verb in relation to the derivative: instigation and performance of the root verb activity. These are the features proposed by Kytömäki (1978 & 1989) for the separation of the agentive properties of curative causatives, as discussed in section 1.2. As mentioned above, Foley and van Valin (1984) also highlight these features in their description of agent features. The features in (f) and (g) can thus be seen as a continuation of Dowty's agent properties:

- f. *instigating* the action denoted by the (root) verb
- g. *performing* the action denoted by the (root) verb

The properties of instigating or performing an action tell us in what way the actor partakes in the event that the root verb encodes. In a typical case, the SAD instigates the action denoted by the root verb, and both the causer-SAR and theme-SAR are performers of this action. This in turn raises a question of control: who is ultimately the controller of the action – the instigator or the performer? Since the SAR has control over the action itself and the SAD controls the whole event, I assume that in a CSD situation the SAD is the ultimate controller (recall also the discussion of 'supreme control' in 2.5). This raises the question: what is meant by activity? We may infer at this point that the SAD and SAR display different types of activity: the SAD affects the SAR through (active) social interaction and instigates the event denoted by the root verb. The SAR represents the actual performance of the root verb activity. At the same time, the SAR's activity is a reaction to the SAD's influence. In respect to the root verb activity, we can thus place the features (f) and (g) of the main CSD arguments as in (5):

(5) Distribution of agent properties of instigation and performance:

	f	g
SAD	+	-
Causer-SAR	-	+
Theme-SAR	-	+

Do the SAR-actors have patient properties as well? Dowty (1991: 573-574) specifies five properties characterising the Proto-Patient; the entailments (6c-e) are the converses of proto-agentive entailments (3c-e), meaning that if a verb has one of the first type arguments, it will also have the corresponding second type of argument:

(6) Proto-Patient properties:

- a. undergoes change of state;
- b. incremental theme;
- c. causally affected by another participant;
- d. stationary (relative to another participant); and
- e. does not exist independently of the event, or at all.

When applying these properties to the CSD arguments, we get the following picture:

(7) Proto-Patient properties of SAR arguments:

	a	b	c	d	e
SAD	(-)	-	-	+	-
Causer-SAR	(+)	-	+	-	-
Theme-SAR	(+)	-	+	-	-

The change property in a CSD situation implies that the change is present if the root verb's lexical information includes directionality and time features (see Nikanne 1990: 56-58); in order for a change to take place, an event must involve a temporal dimension and also a directional element from a starting point and/or to an endpoint. Does movement in itself imply the change of state? The change property generally depends on root verb characteristics as well as on aspectual characteristics of the proposition (this is also discussed in section 5.2.2); therefore, I place the a-values of the SAR roles in parentheses. The b-property or incremental theme is a role category of Dowty (1991: 567) for an NP argument that modifies the aspect of telic predicates by adding information about the state of parts of the whole (as in 'lawn' in 'mow the lawn'). Neither of the SAR types applies this role. Both the causer-SAR and the theme-SAR exhibit the c-property i.e. they are causally affected by another participant. The property of being stationary relative to another

participant (d) does not match the SAR-actors, since they can be in motion with respect to the SAD and the possible OAR. Note that this is the only Proto-Patient property that the SAD acquires. The independent existence of the event property (e) does not apply to the SAD or SAR roles, since they exist both before and after the event.

Specification of the proto-role entailments of CSD arguments shows that the SAD and SAR arguments share some properties and monopolize others. Both the causer-SAR and the theme-SAR possess a higher degree of proto-agent than proto-patient properties. The SAD is not a superior agent in contrast to SAR-actors; the SAD even applies a Proto-Patient property. The agentive properties that all the actor arguments of the CSDs share are (b) and (e) (sentience and independent existence). Variation is related to volitionality, causation and movement, as well as to instigating and performing the root verb activity. Surprisingly, the most prototypical agent according to Dowty's entailments is not the SAD, the first actor, but the causer-SAR, the second actor of the double-causative prototype. In any case, the SAR is the performer of the action, which adds a certain aspect of control over the action expressed by the root verb. Since the SAR is causally affected by the SAD, we can conclude that even a relatively strong actor like the causer-SAR obtains some patient properties. The agentive status of the SAD varies slightly depending on the CSD prototype: in the case of the single-causative prototype, the SAD has greater control over the SAR's activity than in the case of the double-causative prototype. Respectively, the agent properties of the theme-SAR also diminish. The SAR-actors in CSD prototypes are thus not completely identical in their semantic content.

Returning to the discussion in the previous section about UN candidates in connection with the double-causative prototype, the choice is mainly between two arguments: the SAR or the OAR. The relatively high degree of agentive properties of the SAR may be seen as an argument for the OAR as a more natural undergoer than the SAR. On the other hand, these properties may also be seen as an argument for a higher position in the selection of the undergoer. Does the selection of the undergoer depend on the focus of a proposition? According to the information structure idea introduced by Halliday (1967) of pragmatically structured components (the division into recoverable and non-recoverable information), the focus is on new information instead of given information. One can hypothesise that the presence of two actors may imply that the second actor introduces the new information. On the other hand, the implicitness of the SAR may suggest that because this argument does not have to be mentioned explicitly, it represents the insignificant information (see also Pajunen 2001). Nevertheless, the structuring of the content of the information would require a more thorough investigation of the textual characteristics of CSDs than the scope of this study allows. I will return briefly to the question of the selection of the undergoer in section 5.2.6.

The aspects of agentive properties will also form part of the analysis in the discussion of temporal relations and CSD constructions. The relation between the action tier and the temporal character of the situation is a subject within the analysis of the temporal tier of CSDs in the next section (4.3); however, the action tier is also involved in the analysis in chapter 5 discussing constructional patterns related to the CSDs in use. Complex action tier configurations and the significance of the action tier to different types of CSD constructions are discussed further in connection with these topics.

### 4.3 Temporal and causal relations of CSDs

What characterises the temporal relations of social causation in a CSD situation? The internal time flow represented by the temporal tier structure of CSDs is the main topic in section 4.3. I follow the idea of Nikanne (1990) developed by Pörn (2004) that the causal structure of an LCS is determined by the temporal structure. My aim is to examine the effect of the temporal structure on the CSD proposition in terms of the causation-based prototype structures PT1.1 and PT2.2 defined in section 3.4 (also (4) and (5) in section 4.1.2). The focus is thus on the causation event and how it relates temporally to either another causation or transition of theme. Analysis of the temporal structure is expected to shed light on the interaction of the temporal tier in relation to the other levels of the conceptual structure of CSDs.

The temporal study section of CSDs is organised in two main parts. Firstly, I examine the causal-temporal relations of the core CSD sentence and give a formal lexical description of some verbs in sections 4.3.2–4.3.4. These sections are divided further into an analysis based on the double-causative prototype and the single-causative prototype structures. Section 4.3.2 is a discussion of the LCS of some causative verbs derived from causative root verbs (*heitättää* ‘make s.o. Throw’ and *haetuttaa* ‘make s.o. fetch’) and which thus correspond to the double-causative prototype. These verbs enable us to investigate the temporal structure within zone 3 expressing two causations. Sections 4.3.3–4.3.4 typify the single-causative prototype’s temporal structure by involving derivatives with non-causative roots (*juoksuttaa* ‘make s.o. run’, *tanssittaa* ‘make s.o. dance’, *pyöräilyttää* ‘make s.o. cycle’ and its recursive form *pyöräilytyttää* ‘make s.o. make s.o. cycle’). The internal temporal structure of these verbs will explicate the relations between zone 3 and zone 2 of CSDs.

The second part of the temporal study is devoted to CSD expressions in connection with subordinate structures. The analysis in section 4.3.5 will thus cross the lexical boundaries of CSDs – it will concern the constructional complexes of the matrix sentence with a CSD as the predicate connected to an adjunct. This study approaches the effect of a subordinate structure on the lexical core structure, involving complex sentences with a spread of causative

and temporal elements between different conceptual elements. The temporal relations of complex CSD structures are used to reveal the nuances of causation. I aim to specify the causative influence of the adjunct on the matrix structure by examining which temporal sequence of the core sentence the inducement is directed towards.

#### 4.3.1 Temporal tier and causation events

I will begin my temporal study of CSDs with a presentation of the methods I use in the analysis. The basis for the study is the structure of the temporal tier, introduced in connection with conceptual semantics methodology in section 2.2.1. The basic assumption is thus the idea of Jackendoff (1987), proposing that the lexical conceptual structure also includes the temporal tier (T-tier). According to Nikanne (1990: 177-186), the temporal structure of a situation is in the core zones (zones 1 and 2) derived from the thematic structure features, such as whether they are directional and bound e.g. depending on the presence or absence of feature *b*, there can be boundaries on the timeline, while the possible place of the boundary is determined by the features *gl*, *so* or *ro* (for the thematic feature system see section 2.2.1). These features also play an important role in the temporal structure of zone 3, where causation is located.

In connection with the discussion about the nature of causation in section 2.5, it was shown that instead of a treatment of causation as a relationship between an individual and an event, it can be seen as a relationship between two events: the causing event and the caused event. Assuming that the occurrence of the caused event is dependent on the causing event, the time relation between these two events becomes evident. Derived from the idea of the structure-internal temporal structure interacting with the causal structure of an LCS, Jackendoff (1990) distinguishes between two types of temporal effects on causation: ‘entrainment’ describes causation that lasts as long as the caused event, while ‘launching’ is causation that is related to the starting point of the caused event. Basically, the question is how the temporal phrase of zone 3 relates to the temporal phrase of the core zones. Nikanne (1990: 190) provides a formalization of the temporal tier relations of the causative functions that I employ in my analysis of CSDs. The descriptions of the launching and entraining causations are given in (1) and (2) respectively:

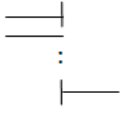
- (1)            **Launching**
- |   |  |
|---|--|
|  | <p>T-tier of causing event</p> <p>T-tier of caused event</p> |
|---|--|

## (2) Entrainment

=  
...

The horizontal line in (1) denotes time duration and the vertical line a point of time. The lines under the temporal structure indicate optionality. Three points indicate that the temporal tier need not be of a specific form. The colon stands for correspondence between the points of time i.e. the end boundary of the temporal tier of zone 3 is the starting boundary of the core zones. The temporal structure of (1) thus indicates that the end point of the causing event corresponds to the starting point of the caused event. The three points in (2) indicate that the temporal tier in question does not have any specific form, and the equal sign (=) means that the causing event and the caused event have the same temporal structure (Nikanne 1990: 188-190). For instance, the T-tier of causation in example (3) has the characteristics of entrainment causation, because the causing event (Jack's carrying the desk) lasts as long as the caused event (the desk being carried). Note that in (3), Z3, Z2 and Z1 stand for zone 3, zone 2 and zone 1 respectively.

(3) *Jake carried the desk into the house.*

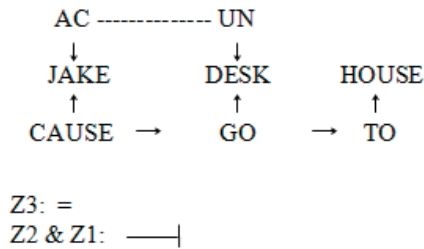

The thematic feature structure of sentence (3) includes the T-node and the D-features in all zones; consider the analysis in (4):

(4) Thematic features of *Jake carried the desk into the house*:

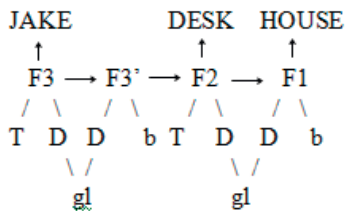



An example of launching causation is given in (5). Note that the thematic feature structure of (5) is identical to that of (4); therefore, I will not present it here.

(5) *Jack sent a letter to Mary.*

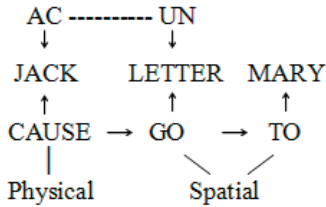

Z3: —|  
:  
Z2&Z1: —|

I will use two kinds of conceptual analysis in the description of causal and temporal relations below: one is presented in (3) and the other in (4). The former includes action tier roles and semantic fields, which can be required in the descriptions of dominance relations between the participants as well as the cognitive background of the situations. The feature hierarchy analysis goes deeper into the thematic structure and, as pointed out earlier, influences the time flow in the propositions. The analysis is basically the same; the feature structure simply presents a more detailed picture of the conceptual structure. Additionally, the T-tier relations of launching and entrainment as presented in (1) and (2) are studied.

#### 4.3.2 Temporal structure of double-causative prototype verbs

A CSD that has a causative verb as the root has two causation events in its LCS, because the LCS of the root verb already includes a CAUSE-function and the causative suffix adds an additional CAUSE-function to it. This CSD hence corresponds to the double-causative prototype. I call the two zone 3 events ‘first causation’ and ‘second causation’ accordingly. An example of a derivative with two causations is *heitättää* ‘make s.o. throw’; a sentence containing this verb and its conceptual structure are given in (1):

(1) *Lauri heittäi kirveen järveen.*

Lauri throw-caus-past-3sg axe-acc lake-ill  
 ‘Lauri had the axe thrown into the lake.’

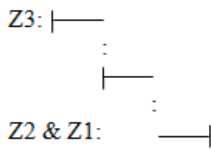
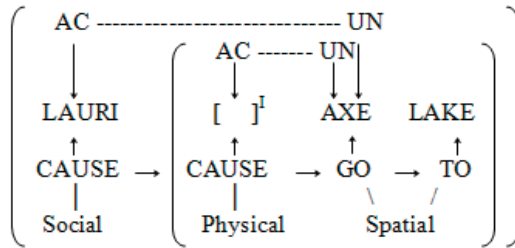

The argument LAURI is selected by the first CAUSE-function and also as the actor for the LCS as a whole. The argument of second causation, the SAR, is not expressed in syntax. The argument in transition, AXE, or the theme, is assigned by the function GO, and the end point of this transition, the argument LAKE, is assigned by the path-function TO. The communicative connection between the two agents is described in the social semantic field. The second causation has the physical semantic field as its background and the transition of the theme is described in the spatial semantic field. In (1), the activity of both actors in the two act-chains is directed towards the theme argument (AXE), the undergoer for both actors.

The temporal tier of example (1) includes three temporal phrases in the LCS, all of which are launching events. As the description in (1) shows, the causations are temporally discrete time lines. Pörn (2004: 33) describes launching causation so that the causer instigates the caused event but does not take part in it thereafter. Is it a lexical feature of CSDs that the first causation is a launching event? The causation zone of (1) includes two causing situations that are simultaneously temporal events. The causing event of the first (seen from left to right in the LCS) causation instigates the second causation. The second causation induces the theme's (AXE) moving along a path, the second caused situation. Both causations in (1) are thus launching events: the first causation launches the second causation, and the second causation launches the event of zone 2 and zone 1. Notice that the time line of the core zones has no starting point, whereas the end point is marked (the axe goes into the lake). The starting point in zone 3 is associated with the first

causation. The thematic features of directionality and telicity with the T-node of structure in (1) are present in all zones; consider (2):

(2) Thematic feature structure analysis of sentence (1)

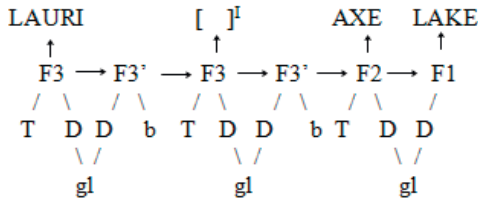

Nikanne (1990:189) points out that when the causation is launching, the end boundary of the temporal tier of zone 3 is the starting boundary of the temporal tier of the core zones. This seems to be the case in the time structure of example (1). What about the time boundaries between the CAUSE-functions inside zone 3? When it comes to the consecutive time relation between events, the starting point of the later event can also be situated at a point later than the ending point of the former event (Herlin 1998: 34-40; Pörn: 2004: 38-41). Consequently, there can be a time gap between events. The linguistic expression in (1) does not actually specify whether the second causation starts exactly where the first causation ends. Correspondence between the end point of the first causation and the starting point of the second can thus not be posited exactly in (1): they can correspond, but there may also be a time gap here between causations. Taking the example in (1), Lauri could have told the thrower (the argument not explicitly expressed) a few days before the throwing act that he should do it. How the correspondence between temporal boundary between the first and second causation is interpreted also depends, therefore, on contextual information.

Next, a sentence with the causative verb *haetuttaa* 'make s.o. fetch' is analysed in (3) and (4). Note that the SAD and the goal argument are co-referential: thus the SAD (LAURI) is indexed with the superscript  $\alpha$ , binding the goal argument marked with the normal size  $\alpha$ . As in the previous analysis, the first causation of this sentence is a launching event. The second causation event of (4) differs temporally from (1): it is not a launching but an entrainment event. This means that the transition of the theme (BOOK), belonging to zone 1 and 2, takes place at the same time as the second causation, carried out by the activity of the SAR. Another difference compared to the LCS of (1) is that the temporal tier of the second causation in (4) does not only contain an ending point but also a starting point. The ending point of zone 3 and the starting point of the core zones do not correspond here, because the second causation is an entrainment event. The entrainment event of second causation is connected to the core zones and not to the first causation.

(3) *Lauri haetutti Katjalla kirjan kirjastosta.*

Lauri fetch-caus-past-3sg Katja-ade book-acc library-ela  
 ‘Lauri had Katja fetch a book from the library.’

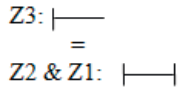
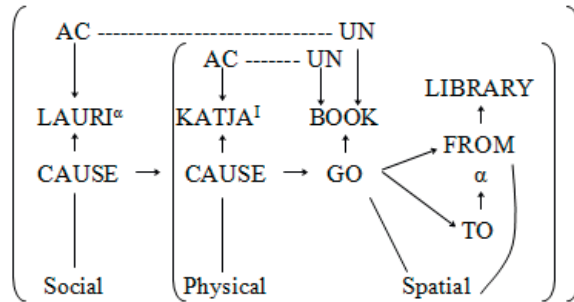

The thematic features of (3) mainly correspond to the analysis in (2). The bound nature of the situation in the core zones reflects the time line fixation atboth ends; thus there is both a source and a goal feature present. The feature analysis is presented in (4):

(4) Feature structure and temporal tier analysis of (3)

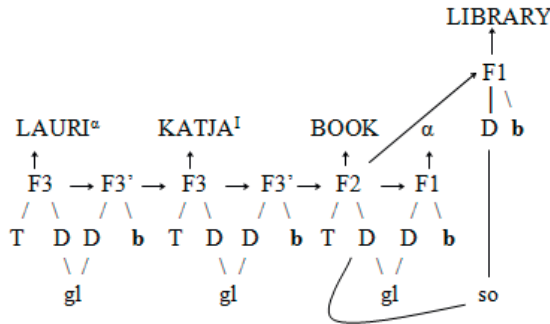

Let us analyse a partially different situation with the same predicate *haetuttaa* ‘make s.o. fetch’, described in example (5)<sup>39</sup> taken from an Internet conversation. The theme argument HE is not moving to the possession of the SAD as in example (3) but away from the SAD. However, this has no influence on the T-tier of the sentence, and it stays the same as the LCS in (4). The first causer instigates the event of second causation without taking

<sup>39</sup> The structure in angled brackets in example (5) is not included in the LCS analysis.

part in it i.e. it is a launching event. As in the analysis of (4), the temporal phrase in the second causation is here also simultaneous with the event described in zone 2 and zone 1. The second causation is thus an entrainment (see (6)).

- (5) *Vaimo [juottaa Laten sammuksiin ja] haetuttaa hänet [sitten] putkaan.*  
 wife fetch-caus-pres-3sg he-acc jail-ill  
 ‘The wife [gets Late drunk and] has him [then] carted off to jail.’  
 (<http://plus.kaleva.fi/cf/juttu.cfm?j=336790>, 13.1.2005)

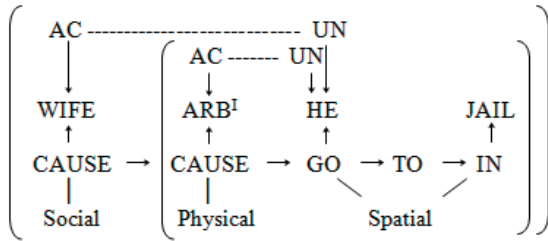

Z3: |—  
 =  
 Z2 & Z1: |—|

- (6) Thematic feature structure analysis of sentence (5)

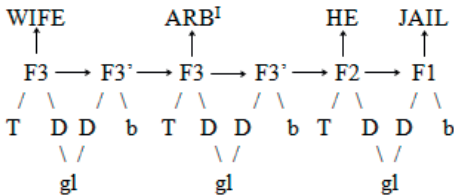

All of the examples above corresponding to the double-causative prototype structure represent launching events as the first causation. Can the first causation of a double-causative CSD also be entrainment? Consider the situation with the verb *ajattaa* ‘make s.o. drive’ in (7). Although the SAD (DRIVING INSTRUCTOR) is not performing the caused activity (driving), he is most probably participating in the driving situation by instructing the SAR referent. The first causation may thus be interpreted as lasting throughout the situation. In this case the first causation in (7) may be analysed as entrainment. However, the causation of the SAD is of an instigating nature, and the situation in (7) may also be interpreted so that the SAD does not participate in it after the starting point. In this case, the temporal structure of the first causation is launching. We can say that the situation in (7) is ambiguous and that the first causation is neither clearly

entrainment or launching; therefore, I mark the alternative temporal readings of (7) in zone 3 using curled brackets and a slash between the optional senses ( $\{X/Y\}$  meaning ‘X and Y are alternatives’).

(7) *Autokouluopettaja ajattaa Mattin keskustaan.*

driving.instructor drive-cause-pres-3sg Matti-acc centrum-ill  
 ‘The driving instructor has Matti drive to the city centre.’

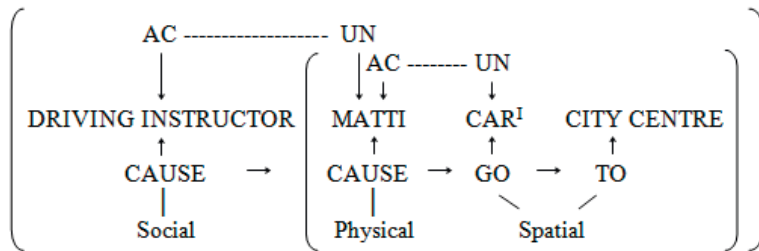

Z3:  $\{ | \text{---} \} / \{ = \}$

=

Z2 & Z1:  $\text{---} |$

### 4.3.3 Temporal structure of single-causative prototype verbs

In this section I examine the temporal structure of CSDs derived from root verbs that are not causative. The predicate of sentence (1) below is the motion verb *juoksuttaa* ‘make s.o. run’. The agentive motion denoted by the root verb is not seen here as a causative action, even though it is sometimes argued that the motion performed by the mover’s own force is also a causative action. The agent in motion encoded by the verb ‘to run’ is analysed within conceptual semantics as the theme, not the causer. For instance Pajunen (2001) claims that from the ontological point of view, all motion can be seen as caused: behind ‘uncontrolled motion’ there is some kind of reason (wind, change of weather); the causer of a ‘controlled motion’ is the mover itself, some other animate entity or some force (a machine). I concentrate on purely semantic analysis here, and simply note that all agentive activity is not necessarily equal to causation; let us call the type of controlled motion performed with one’s own force ‘self-agentive motion’. Hence if there is only one CAUSE-function in the LCS of a CSD, the SAR is not located in zone 3, but in zone 2. The agentive features of the SAR (KATJA) in sentence (1) are expressed in the act-tier: the SAR is the role actor in the lower action tier, which means that this argument is an active participant in the situation. However, the activity performed by the SAR is

not directed at another participant or causing another event. The temporal tier of example (1) is characterized by two launching events.

(1) *Lauri juoksutti Katjan kauppaan.*

Lauri run-caus-past-3sg Katja-acc shop-ill

‘Lauri had Katja run to the shop.’

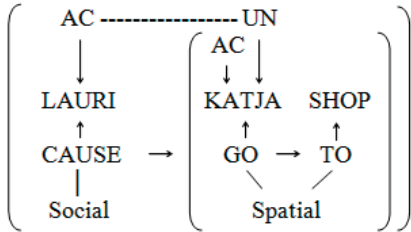

Z3: |—

:

Z2 & Z1: |—

(2) Feature structure and temporal tier analysis of sentence (1)

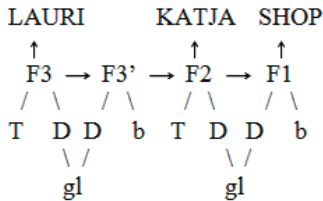

Example (3) with the verb *tanssittaa* ‘make s.o. dance’ has two possible readings due to the ambiguity concerning the participation of the SAD in the caused situation. The example may read that both the SAD and SAR take part in the dancing activity if they dance together, or it may imply that Lauri did not dance with Katja (for instance if Katja danced to the music Lauri was playing on an instrument). Temporally, the causation of proposition (3) is in both cases an entrainment event, since the causing event lasts as long as the caused event. The semantic field of causation of (3) may be interpreted as physical or social; therefore, I leave it unmarked in this case. Note that the situation in sentence (3) is unrestricted, and feature b (the bound nature of the situation) is absent in the thematic feature analysis in (3). Thus, the timeline of the core zone situation is an unrestricted period. In the conceptual structure of (3), the zone 2 function is MOVE, whose argument is undergoing some sort of activation, connected with the notion of time (notice the presence of the T-feature in (4)). This activation is not directed at anything; the D-feature is therefore absent in zone 2.

(3) *Lauri tanssitti Katjaa.*

Lauri dance-caus-past-3sg Katja-part

'Lauri had Katja dance (=danced with Katja).'

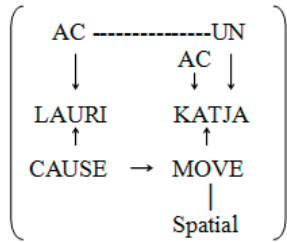

Z3: =

Z2 &amp; Z1: —

## (4) Feature structure and temporal tier analysis of sentence (3)

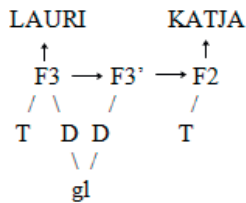

How does the entrainment reading reflect the characteristics of the actors? Are the SAD and SAR more equal agents in an entrainment verb than in launching? Naturally, entrainment causation expresses more direct involvement in causation. Pajunen (2001) argues that in symmetric relations (fight, dance, meet etc.), the participant linked to the subject is often seen to be the more controlling and emphatic one. Also, in example (3), the SAD is the one that controls the situation. Thus, the status of the SAD as the ultimate controller seems to be confirmed regardless of the temporal causation type (compare to the discussion in 2.5 and 4.3.2); even if the SAD referent does not take part in the activity denoted by the root verb, the SAD is the participant that controls the situation. This is also visible in the action tier configuration: the act-tier of (3) is exactly the same as in (1), where the T-tier has the launching reading, and consequently, the SAD does not participate in the activity. The SAD assigns the role actor in the upper action chain in both cases; the SAR (KATJA) is selected as both the actor and undergoer.



#### 4.3.4 Ambiguity in interpretation of argument structure

The root verb of the next CSD in focus, *pyöräilyttää* ‘make s.o. cycle’, denotes motion by means of a vehicle, carried out using an agent’s own force. I have chosen this verb for analysis because of its behaviour in respect to the root verb: the semantics of this derivative have to some extent an open interpretation when it comes to the performer of the root verb activity. Following the compositional sense, the SAR referent carries out the activity denoted by the root verb: in this case the meaning should be ‘make s.o. cycle’. However, this is not necessarily the case, as language use shows, and the SAR’s activity can vary in respect of the root verb denotation. Consider sentence (1):

(1) *pyöräilyttää* [cycle-caus] ‘make s.o. cycle’

*Muista pyöräilyttää koiraa molemmilla sivuilla, varsinkin jos koira tykkää mennä hihna kireällä.*

(<http://forum.prettybit.fi/viewtopic.php?p> , 25.9.2007)

‘Remember to cycle with the dog on both sides, especially if the dog likes to run on a tight leash.’

The meaning of *pyöräilyttää* ‘make s.o. cycle’ in example (1) is ‘let a dog run or walk while cycling’ and the SAD is performing the action denoted by the root verb, while the SAR does a different kind of activity (in this case running or walking). This particular sense (‘make a dog run’) of *pyöräilyttää* is used among dog enthusiast groups. The analysis of a sentence with *pyöräilyttää* is given in (2). According to the LCS of sentence (2), the SAD’s motion also causes the SAR’s motion and the semantic field in zone 3 is physical, not social. The causation here has an entrainment reading. Thus, the SAD is participating in the motion event, but the type of motion is different. The fact that both arguments are in motion is sufficient for a reading that the arguments take part in the same event. The SAD is also the controller of the event. The SAD in the LCS of sentence (2) is indexed with the superscript  $\alpha$  and binds the argument marked with the normal size  $\alpha$  in the substructure describing the manner of motion. The important factor is thus that the performer of the root verb activity is not the SAR but the SAD.

(2) *Matti pyöräilyttää koiraa.*

Matti cycle-caus-pres-3sg dog-part

'Matti gets the dog to run by going cycling.'

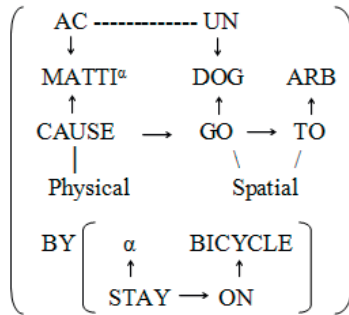

Z3: =

Z2 &amp; Z1: |—

## (3) Feature structure and temporal tier analysis of sentence (2)

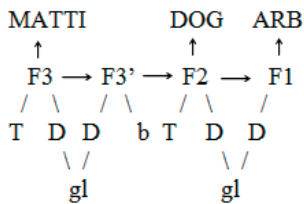

The example in (4) is a more theoretical one: the predicate is derived one extra step from *pyöräilyttää* 'make s.o. cycle' by adding an additional causative suffix *ttä* to the root. As Pennanen (1984) points out, Finnish causative derivation satisfies the syntactic-semantic criteria of a recursive process: it operates with the same derivation suffix, modifying the root verb with every derivational step, and moves the causer of the event denoted by the root verb one step further away. Following the productive compositional rule, the meaning of the verb *pyöräilyttää* should then be 'make s.o. make s.o. else cycle',<sup>40</sup>

<sup>40</sup>In practice, the recursivity assumption does not necessarily hold true; I have two examples from Internet material of the verb form *pyöräilytyttää* [cycle-caus-caus], both of which are semantically identical to the single-causative variant *pyöräilyttää* [cycle-caus] as discussed in examples (1) and (2).

- (4) *Matti pyöräilyttää koiraa vaimollaan.*  
 Matti cycle-caus-caus-pres-3sg dog-part wife-ade  
 ‘Matti has his wife go cycling with the dog.’

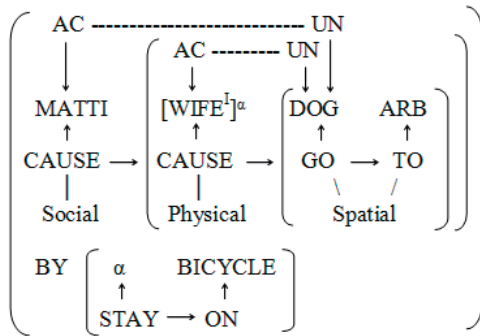

Z3: |—  
 =  
 Z2 & Z1: —|

- (5) Feature structure and temporal tier analysis of sentence (4)

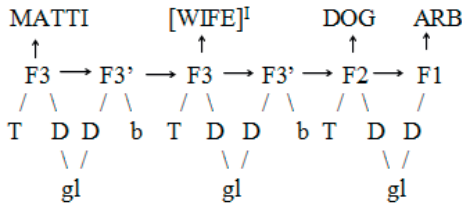

The recursive derivation process thus adds a second ‘cause’-function to the LCS. As example (4) shows, the meaning of *pyöräilyttää* [cycle-cause-cause] ‘make s.o. take the dog for a run by cycling beside it’ is more complex than the compositional rule would predict, including two different types of motion. The activity of the SAD (MATTI) is an unspecified kind of social persuasion, explicitly not cycling. As described in (4), the argument actually cycling (‘wife’) i.e. the performer of the activity denoted by the verb *pyöräillä* ‘to cycle’ is the subject argument of the root verb *pyöräilyttää*. The object argument of this sentence is the subject argument of the root verb *pyöräillä* ‘to cycle’. The type of motion of the argument (DOG) is thus not specified; most likely it is not cycling, but running or walking. It can be inferred that the participant being able to perform the cycling activity in a sentence with *pyöräilyttää* or *pyöräilyttää* has to be +human. The temporal structure of the first causation in (4) is launching, because the SAD does not participate in either the cycling or running event. The second causation is

entrainment even though this entrainment event involves different kinds of activities, as the SAR (WIFE) is cycling and the OAR (DOG) running. The common element is that they both move together in the same direction.

In the sentences analysed above, the cycling activity (denoted by the root verb) of the SAR was excluded. What kind of activity are the referents of SAD and SAR arguments of *pyöräilyttää* ‘make s.o. cycle’ performing when they are both +human? How does this influence the temporal structure of a sentence? Consider example (6) and its conceptual structure. The activity that the SAR (PEKKA) performs is cycling; this argument is thus indexed with  $\alpha$ . The activity of the SAD (COACH) in this case is not specified. Therefore, the causation can be interpreted as an entrainment event if the SAD also cycles or follows the SAR, for instance in a car; if the SAD does not follow the motion of the SAR, it is a launching event. The path expressed in the core zones has no clear boundaries; thus, I mark the end-point of it with the generic argument ARB. The temporal character of the causation therefore depends in this case on contextual information. However, the semantic field in both interpretations is social. I mark the alternative temporal readings of (6) in zone 3 with curled brackets and a slash between the optional senses ( $\{X/Y\}$  meaning ‘X and Y are alternatives’).

- (6) *Valmentaja pyöräilyttää Pekkaa harjoituksissa.*  
 coach cycle-caus-pres-3sg Pekka-part training-ine  
 ‘The coach has Pekka cycle during training.’

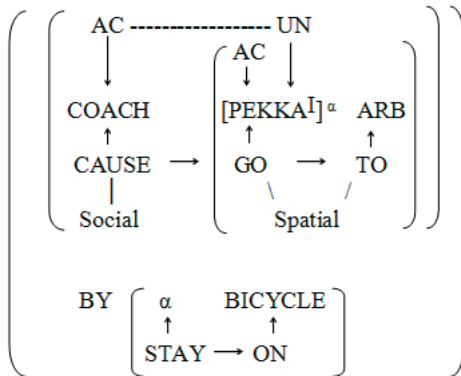

Z3: { | — } / { = }

:

Z2 & Z1: —

Depending on pragmatic implications, it can be even more complicated to infer the nature of the activity the participants are performing. Consider example (7) below, an authentic sentence from a discussion concerning experiences of hen nights.

- (7) *Kaaso pyöräilytti minua ympäri kaupunkia /---/*  
 bridesmaid cycle-caus-past-3sg I-part around city-part  
 ‘The bridesmaid had me cycle around the city.’  
 (<http://keskustelu.suomi24.fi/show.fcgi?category=2000000000000008&conference>, 14.11.2006)

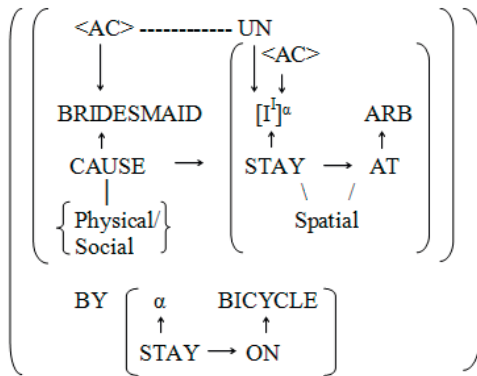

Z3: { | — } { = }

:  
 Z2 & Z1: —

The temporal tier of (7) is similar to structure (6): the temporal reading and the nature of first causation depend on the SAD's type of participation in the event. The angled brackets < > in (7) indicate optionality and the curled brackets with a slash ( { / } ) indicate alternatives, describing the open readings of this sentence. Example (7) has at least three possible interpretations for the whole situation; the description in (7) strives to integrate these readings. Note the differences in the action tier configuration: both the SAD and SAR have optional actor roles, depending on the way they participate. In the analysis of temporal relations, I interpret the motion of the SAD and the SAR together as an entrainment event, regardless of the means of motion (cycling, driving a car or perched on a bicycle being ridden by someone else). Notice that the semantic field of the causation depends on the way the SAD (BRIDESMAID) takes part in the activity which the SAR performs. If the SAD cycles or in some other way follows the SAR, the semantic field is spatial; if the SAD does not spatially follow the SAR, the semantic field is social. The three interpretations are presented below:

- (a) Bridesmaid cycles, “I” cycles. The causation is an entrainment event; both arguments are actors.
- (b) Bridesmaid cycles, “I” does not, but moves with the bridesmaid (is also on the bike or follows in a car). The causation is an entrainment event. There is only one actor in the LCS when “I” sits on the bike. In this case the semantic field is also physical – the bridesmaid physically causes the motion of “I”.
- (c) Bridesmaid does not cycle or move with “I”, “I” cycles. The causation is a launching event. There are two actors performing different kinds of activities.

Based on the examples analysed in 4.3.2-4.3.4, we can infer that the temporal character of the first causation reflects the instigator-participant-performance-related nature of CSD-actors, the SAD and the SAR. When the SAD instigates but does not participate in the action denoted by the root verb, the first causation in the structure of the CSD is a launching event. When the SAD participates in the root verb event, it is an entrainment event. The examples above raise the question of what is regarded as participation: is the significant factor the partaking in the activity denoted by the root verb, or participation in the situation connected to the event as a whole? Based on the examples in this section and also (7) in section 4.3.2, I would argue that the type of activity does not necessarily matter when it comes to temporal relations between events; more important is participation in the event itself. On the other hand, even when participating in the event denoted by the root verb, the SAD is still the instigator and controller of the situation (for instance in the case of *tanssittaa* ‘make s.o. dance’). Taking a CSD with a motion verb as its root, the fact that the SAD moves in the same direction as the SAR (on the bicycle or in a car) is sufficient to give the event an entrainment reading. However, in the case of double-causatives, in derivatives that have two CAUSE-functions in their LCS the first causation tends to be a launching event. CSDs corresponding to the single-causative prototype vary more freely between both types of temporal relations and seem to be more open to pragmatic implications, depending on the type of activity the main arguments are performing. However, both double- and single-causatives encode launching causation in their conceptual structure, which strengthens the inductive causation reading.

We can conclude that the agentive properties ‘instigating the action denoted by the predicate’ and ‘performing the action denoted by the predicate’ discussed in section 4.3 have certain dependence with the temporal tier structure of CSDs. When the first causation is launching, the actor assigned by its argument (the SAD) is an instigator. When the causation is entrainment, the actor assigned by the SAD is not necessarily the performer of the root verb activity, but participates in the event in some way. The participation does not have to mean activity, as interpretation (b) of sentence

(7) above indicates. Thus, the temporal structure may have an effect on the action tier.

#### 4.3.5 Causative subordinate structures and effect on core sentence

The subject of observation in sections 4.3.2-4.3.4 was the internal temporal structure of CSD causations related to actor-arguments. In this section I will focus on the argument structure of causative derivatives in connection with a causative (subordinate) adjunct and on the causal-temporal relationship between them. I will examine CSDs with more idiosyncratic behaviour with the emphasis on the division of causal relations between different linguistic representations in section 4.3.6. My aim in connection with complex CSD structures is to produce a description of causal and temporal relations outside of the matrix structure.

In order to approach subordinate causative structures, it is important to note that the timeline of adjuncts falls out of the scope of the temporal tier (T-tier) discussed above. How is the time flow of the matrix structure associated with the subordinate structure? In Nikanne (1997a: 344) this problem is solved by assuming a separate temporal tier, the ‘constructional T-tier’ or ‘CT-tier’, which relates the temporal tier of a core sentence to that of an adjunct. According to this theory, the T-tier of the core sentence and the T-tier of the adjunct are separately linked to the CT-tier. The CT-tier itself has no exact structure; it is seen as a schematic notion. It is characterized by correspondence to a linear time course that can be divided as follows: the beginning part of the shared T-tier describing the earlier time sequence and the final part of the latter time sequence. If the CT-tier is divided, the abbreviation CT1 stands for the chronologically earlier part of CT and CT2 stands for the chronologically latter part of CT. The structure of the CT-tier can be described as in the following figure (Nikanne 1997a: 344-345.):

a. Unitary CT-tier

CT  
-----

b. Divided CT-tier

CT1   CT2  
----- | -----

When the T-tiers of the core sentence and the adjunct are related to the CT-tier, the logical relationship notions ‘is equal to’, ‘is included in’ and the negative ‘is not included’ are used. X represents the T-tier of the adjunct and Y represents the T-tier of the matrix sentence. The possible CT relations are described in (1):

- (1)  $X = Y$  means ‘X is equal to Y’  
 $X \in Y$  means ‘X is included in Y’  
 $X \notin Y$  means ‘X is not included in Y’

The temporal structure of a sentence with a CSD and an adjunct can thus be analysed as in (2):

- (2) *Benitez ottelutti maalivahteja ykkösvahdin paikasta.*  
 Benitez compete-caus-past-3sg goalkeeper-pl-part first.keeper-gen place-  
 ela  
 ‘Benitez had the goalkeepers compete (in a match) for the position of first  
 keeper.’

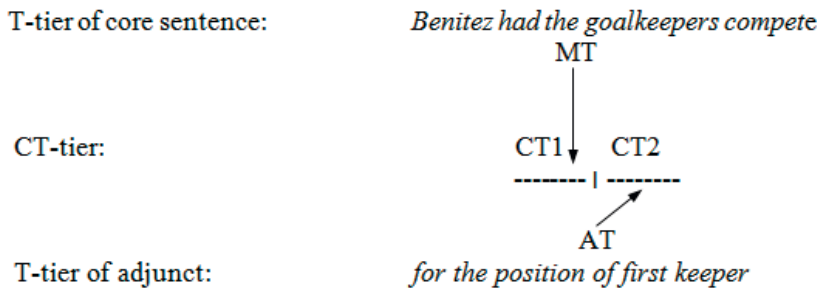

In the temporal tier analysis of sentence (2), the T-tier of the matrix sentence (I use the abbreviation MT here) is included in CT1, and the T-tier of the adjunct (marked as AT) is included in CT2. Temporally, the event described in the core sentence is thus chronologically earlier than the event described in the adjunct – gaining the position of first keeper follows the competing event of the goalkeepers. Applying the marking system of (1), this relationship can be described as follows:

$$AT \in CT2 \ \& \ MT \in CT1$$

Note that the T-tier of the matrix sentence in (2) would be an unbound region of time if there were no adjunct: the competition takes place until the position of first keeper is awarded to somebody. The adjunct construction is hence binding the situation in the core sentence.

The analysis above deals with the purely temporal relationships of the structure in (2). How does the chronological time order of the CT-tier in example (2) correlate with the causal representation? Is the temporally earlier part of CT also the cause of the temporally later part? In light of sentence (2), we can say that there is no correlation: the requirement to award the position of first keeper to one of the goalkeepers is there before the start of the



competition. Hence the situation expressed by the adjunct is the reason for the matrix sentence situation, whereas temporally, the adjunct situation follows the matrix structure. In order to keep the temporal and causal structures apart and to distinguish between the causative relations of the core sentence and adjunct, I suggest that the following causative subordinate operators are needed:

- (3) **CS↓** the matrix sentence causes the adjunct's situation (LEAD TO)  
    **CS↑** the adjunct structure causes the situation in the matrix sentence  
        (BECAUSE OF)

The causal operators reflect the two sides of causation: **CS↓** expresses that the subordinate structure is a result of the event described in the matrix sentence, while **CS↑** indicates that the subordinate structure is the reason for the situation described in the matrix sentence. The conceptual structure including the causative operator of the sentence given in (2) is analysed in (4). Note that the adjunct structure falls within the scope of the subordinate causal operator **CS↑**, since the adjunct situation is the cause of the situation described in the matrix sentence. The semantic tier of the adjunct structure is possessive, as the verb 'to compete' implies that the winner will possess something as a result of the competition. This event is temporally situated in the future in respect of the competition event itself – while the competition is ongoing, nobody is awarded the prize<sup>41</sup>.

---

<sup>41</sup>The causing event may be placed temporally in the future with respect to the caused event, as Pörn (2004: 36) points out in her study of Finnish emotive causatives (derived with the same morpheme *ttA* as the causatives studied in this article). The causing event in this case is interpreted as a thought about the coming situation, a non-factive event (for instance 'travelling to Helsinki tomorrow' in *Minua pelottaa huomienen matka Helsinkiin* 'Travelling to Helsinki tomorrow has got me worried'). In this case, the causative interpretation seems to be **CS↑**.

## (4) Analysis of sentence (2)

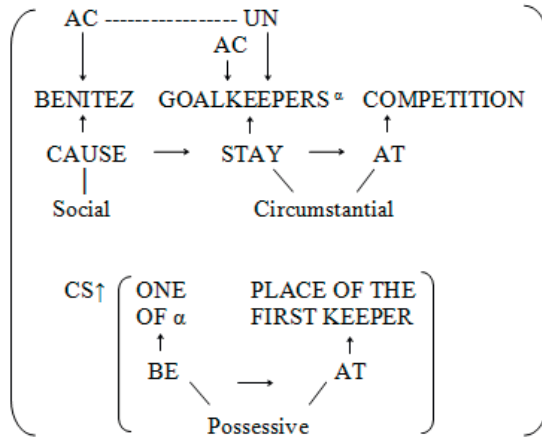
4.3.6 The verbs *tapattaa* [kill-caus] and *itkettä* [cry-caus]

Until now all of the verbs analysed have been the result of productive compositional processes: transparent derivatives. The next CSD I will look at, *tapattaa* 'make s.o. kill', is an example of a more idiosyncratic CSD. The particular nuance of this verb is that it involves a lexicalized spatial adjunct (a place or path adjunct, as the examples below will show) with a causative meaning. The lexical conceptual structure of *tapattaa* is presented in (1):

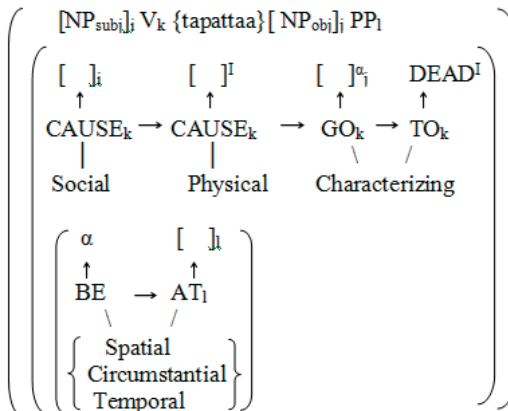
(1) Lexical entry of *tapattaa* 'make s.o. kill'

There are two causations in the LCS of *tapattaa*. The structure of the verb consists of two implicit arguments: the SAR argument in the second

causation and the implicit argument ‘dead’ in zone 1. The semantic field in the core zones is characterizing – the background to the event is a situation where the theme argument is finally characterized by being dead. The first causation has the social semantic field as its background and its second causation is the physical, which does not deviate from the prototypical CSD. The causative adjunct corresponds to the figure BE → AT, and the argument  $\alpha$  selected by the f2-function is bound to the f2-argument of the upper structure, indexed with  $\alpha$ . The index on the place of an argument indicates that the argument in question is represented in both places in the LCS. The semantic field of the adjunct can have different interpretations: the spatial (the theme argument is in a place), temporal (when the temporal location of the theme argument and the object of the killing is emphasised) or circumstantial semantic field (the situation of the theme's being in the place).

The example in (2) illustrates the semantics of this verb. The action tier of (2) describes the negative effect of the activity of the argument selected by the upper act-chain actor (GENERAL) on the undergoer (SOLDIERS). The undergoer of the upper act-chain marked assigns the subrole malefactive (UN-). Note that the malefactive argument (SOLDIERS) is also the undergoer of the lower act-chain, but this role is neutral (UN), because in this case the nature of the effect of the (arbitrary) actor is not unambiguously specified. The scope of the spatio-causative adjunct *rintamalla* ‘on the front’ is notable; the adjunct structure is the reason for the situation described in the root verb structure and not the whole derivative structure. Therefore, in (2), the root verb structure is separated using brackets, marking the scope of CS $\uparrow$ . This configuration supports the assumption that in the case of derived verbs with two action tiers, the role actor also marks the boundaries of lexical units (Nikanne 1998).

(2) *Kenraali tapatti sotilaitaan rintamalla.*

general kill-caus-past-3sg soldier-pl-part-px3sg front-ade  
 ‘The general got his soldiers killed on the front.’

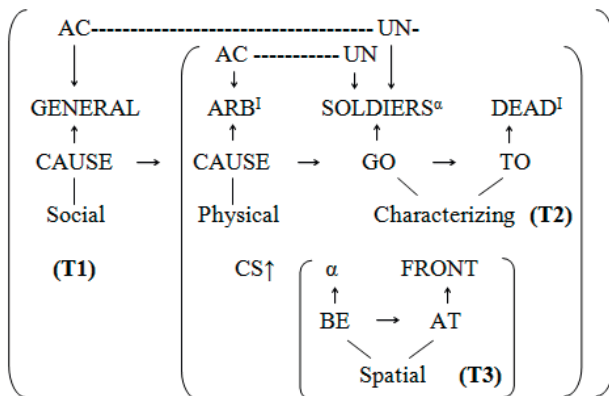

What is the effect of the lexical boundary of CSDs on temporal structure? As an implication of the boundary confirmed also by the adjunct structure between the first causation and the root verb structure, the T-tier of the matrix sentence in the CT-tier is also divided. To explicate different parts of significance to the CT-tier, I mark them with the abbreviations **T1**, **T2** and **T3** in (2). Accordingly, the T-tier of the matrix sentence is divided into two parts so that the first causation falls within the scope of T1, the second causation with the zone 2 and zone 1 structure falls within the scope of T2, and the adjunct structure falls within the scope of T3. The analysis in (3) describes how these temporal units are represented in the CT-tier. The structure of zone 3 is thus split; T1 is included with CT1 while both T2 and T3 are placed with CT2 in the CT-tier.

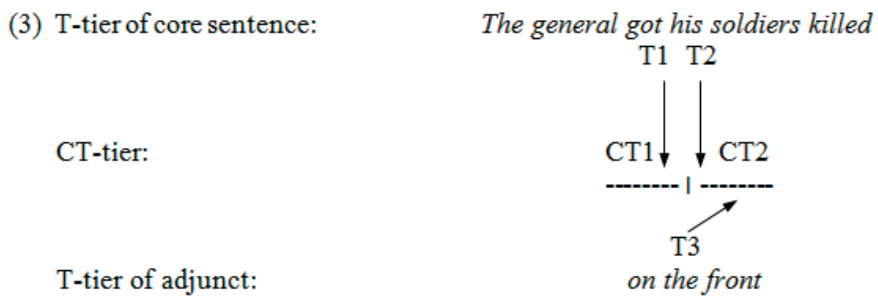

The logical analysis of these time relations is presented in (4), where T1 is included in the first part of the CT-tier and both T2 and T3 are included in the second part of the CT-tier:

- (4)  $T1 \in CT1$   
 $T2, T3 \in CT2$

The next example is taken from NS (Nykysuomen sanakirja, the contemporary Finnish dictionary). Example (5) includes two subordinate structures with a causative meaning. In the sequence *hevostani tapattamaan* ‘to get my horse killed’, the form of the verb *tapattaa* ‘make s.o. kill’ is the third infinitive illative (the ‘MA-infinitive’). According to ISK (2004: 473), the MA-infinitive in the illative case builds the ‘orientation/direction construction’ with the inchoative matrix verb *lähteä* ‘to go, take off’ and expresses the situation that the object argument (linked to the argument HORSE in the CS) turns into. The second adjunct structure, *heikoille jäille* ‘onto the thin ice’, is in turn an adjunct of the infinitive construction. In (5), the situation expressed with the infinitive construction is the goal or aim of the subject argument, which is changed to the negative form. Because the situation expressed in the matrix sentence causes the adjunct’s situation, the

subordinate construction is marked as CS↓ in (5). This adjunct situation is in turn caused by a spatial subordinate structure i.e. it is marked as CS↑.

(5) *En lähtenyt heikoille jäälle hevostani tapattamaan.*

not-1sg go-ptc weak-pl-all ice-pl-all horse-part-px1sg kill-caus-3inf-ill

'I did not go out onto the thin ice [so as not] to get my horse killed.'

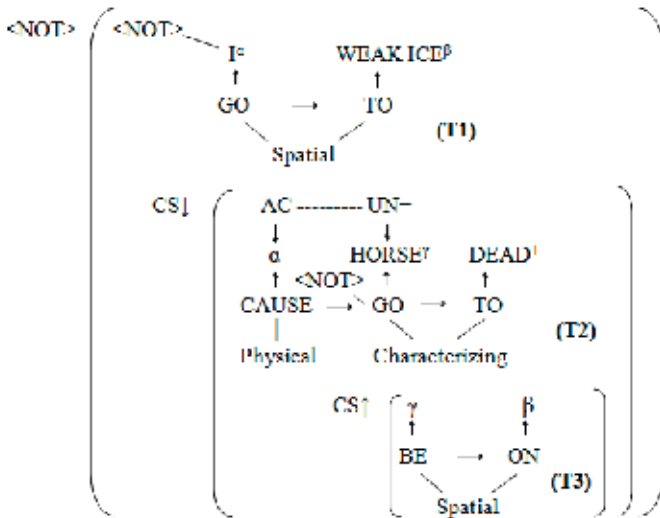

In (5), the temporal sequences T1, T2 and T3 are distributed on the CT-tier as follows: T1 restricts the T-tier of the matrix sentence, whereas T2 and T3 stand for the T-tiers of the adjuncts. The fact that the proposition in (5) is a negative, hypothetical sentence raises further questions. What is the scope of the negation? How does it impact on causative and temporal interpretation? There are at least two possible readings of the sentence in (5) (I mark the possibility of different readings caused by the notion of negation with angled brackets in (5) as the optionality of the operator NOT):

- (a) 'I' went out onto the ice but the horse did not.
- (b) Neither 'I' nor the horse went out onto the ice.

In (b), the whole proposition is negated, so in this case it cannot have a T-tier at all. I suggest that in the case of (a), only the matrix sentence has a T-tier, because it is not negated, while the subordinate structures fall within the scope of negation and cannot have a T-tier. Hence, the absence of a temporal tier does not affect the existence of causative relations. Since only the T-tier of the matrix sentence is represented in this construction, it is not possible to give a description of CT-relations.

There are thus several possible interpretations of sentence (5), depending on focus and deictic properties. Since the temporal relations of sentence (5) are based on its positive account, let us examine the positive version of it, in order to clarify the inner time flow of the situation. The proposition in its positive form is analysed in (6), describing the temporal and causal relations in this complex situation. The significant aspect of this structure is that the situation in the matrix sentence causes the situation in the adjunct, marked as  $CS\downarrow$ . The situation of this adjunct is in turn caused by the spatial adjunct, marked as  $CS\uparrow$ .

(6) *Lähdin heikoille jäälle hevostani tapattamaan.*

go-past-1sg weak-pl-all ice-pl-all horse-part-px 1sg kill-caus-3inf-ill  
 'I went out onto the thin ice to get my horse killed.'

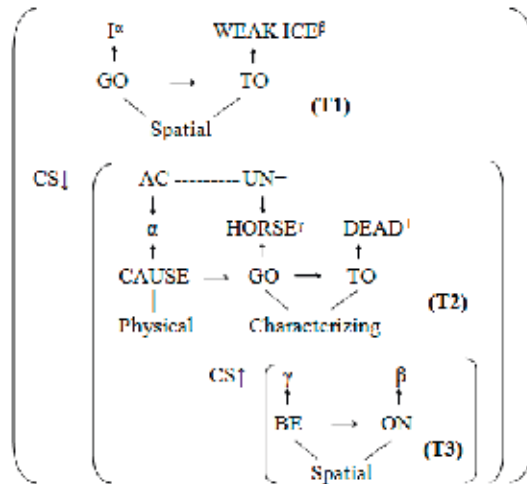

What is the distribution of time components of structure (6) on the CT-tier? The temporal sequences are related to the CT-tier in (7), and its logical description is given in (8):

(7) T-tier of core sentence:

CT-tier:

*T-tier of adjunct:*

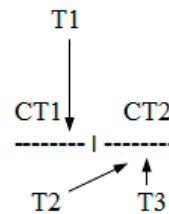

(8)  $T1 \in CT1$

$T2, T3 \in CT2$

The next sentence (9) is an authentic example from the Finnish evening paper *Ilta-lehti*. The predicate of the sentence is the causative derivative *itkettää* ‘make s.o. cry, weep’, and the subordinate structure consists of the instrument-like adessive case adjunct *töräytyksillä* ‘with slurs’<sup>42</sup>. The conceptual structure of this example is analogous to the analysis in (2) – the scope of the adjunct structure is restricted to the root verb and does not extend to the derivative structure as a whole. In contrast to the causative relations of (2), the subordinate structure is marked as CS↓ because here it is caused by the situation expressed in the matrix structure. Note that the adjunct structure is fused with the matrix structure. The semantic fields of analysis in (9) differ from other examples in this section. As both communicative and mental states are involved in this proposition, I mark the semantic field of the causation as communicative and the semantic field of the core zones as mental. This is based on the observation that we can talk about communicative and mental states using possessive structures (Jackendoff 1976 and Nikanne 1986); here, the mental semantic field may thus be seen as a subtype of possession. The weeping is taking place in the circumstantial semantic field:

(9) *itkettää* [cry-caus] ‘make s.o. cry’

*Lue, millä töräytyksillä Idols-tuomarit itkettivät tänä vuonna kilpailijoita.*  
 read-imp which-ade slur-pl-ade Idols.judge-pl-nom weep-caus-past-3pl  
 contestant-pl-part  
 ‘Read about the slurs the Idols judges came out this year to **make** the  
 contestants **cry**.’ (*Ilta-lehti* 13.10.2005)

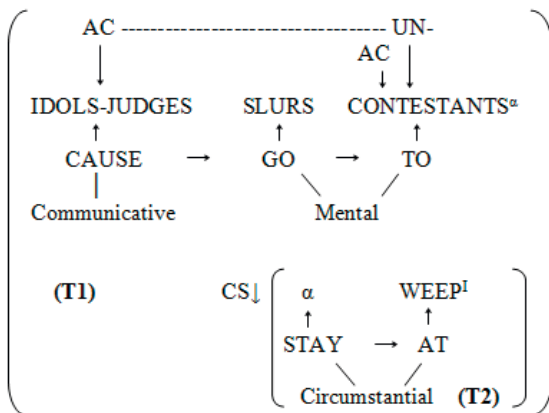

<sup>42</sup>I leave out the verb *lue* ‘to read’ of the main clause and only analyse the sub-sentence with the adessive adjunct in the LCS analysis of (34).

Analysis of the CT-tier of example (9) in (10) indicates that the (T1) situation is a continuous situation located throughout the CT-tier and that the adjunct structure (T2) is located on the CT2. Temporally, the manner of causation expressed by the adjunct structure is bound with the causation expressed in the matrix sentence. This suggests that if the causing event involves the use of some kind of manner or instrument by the causer, the causal effect of the manner is closely connected to the causal effect created by the causer. An additional remark here is that the situation in (9) is frequentative, repeated with several contestants; this is not expressed in the description (10).

(10) T-tier of core sentence:

CT-tier:

T-tier of adjunct:

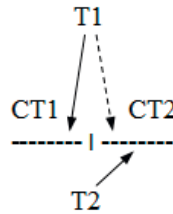

The same temporal relations are given their logical form in (11):

(11)  $T1 \in CT1 < \& CT2 >$

$T2 \in CT2$



## 4.4 Conclusions on interplay of causation, activity and temporal structure

The study in this chapter involves complex semantic relations expressed by CSDs: the agentive features of the main participants and the temporal structure of subevents. These are different levels of description, but as the analysis in this chapter indicates, they have an impact on each other. The first part of this chapter discussed the complex action tier configurations CSDs display. CSDs typically involve two actors in their own act-chains, due to the lexically strong status of the root verb in the CSD derivative. Both the SAD- and SAR-actors display agent properties in the Dowtian sense and, in addition, some patient properties. The SAR-actors in both the causer and theme roles are relatively strong agents, in addition to the SAD, the participant that typically controls the whole CSD event. The analysis in sections 4.1-4.2 can also be seen as a test of conceptual structure methodology dealing with the notion of agentivity. The agent properties were discussed within different levels of the conceptual structure, involving the action, thematic and semantic fields tier as well as semantic and thematic features.

The second part of the discussion in chapter 4, section 4.3, was directed at an analysis of temporal and causal relations. The first part of this study (4.3.1-4.3.4) dealt with the lexical core of the derivatives in question, the lexical conceptual structure. It focused on the internal temporal structure of both causatives derived from causative root verbs as well as causatives with non-causative roots. The study of the temporal tier revealed that the first causation is a launching event if the SAD does not take part in the action denoted by the root verb. This type of causation is closely connected to the question if the SAD takes part in the event encoded by the root verb. In this context, the type of activity is not automatically significant. A result of the temporal study of CSDs is that both double-causative and single-causative prototype verbs can have launching and entrainment readings. The verb's temporal reading was found to be influenced by the agent properties of the CSD actors. Analysis indicates that when the first causation is launching, the actor assigned by its argument (the SAD) is an instigator and does not take part in the caused event. When the causation is entrainment, the actor assigned by the SAD is not necessarily the performer of the root verb activity, but participates in the caused event in some way. The key outcome of the analysis of temporal and agentive properties is thus that the instigating and performing features are related to the temporal structure of the LCS. We saw also that the criterion of a prototypical curative causative (see the discussion in section 1.2), the SAD launching the action that the SAR performs, does not categorically hold even for transparent derivatives.

The second part of the temporal analysis (sections 4.3.5-4.3.6) was a study of complex causative structures. The focus was on the core CSD sentence

linked to a subordinate structure with causative denotation. The main question was how a causative adjunct influences the complicated causative proposition that a CSD sentence constitutes. One finding of the investigation is that chronologically, temporality and causality do not necessarily correspond. As a consequence of this, I have introduced special causal operators to distinguish between causal subordinate relationships, **CS↓** and **CS↑**, expressing that the subordinate structure is a result of the event described in the matrix sentence and that the subordinate structure is the reason for the situation described in matrix sentence respectively. **CS↑** adjunct structures showed an interesting tendency: the scope of the adjunct does not always cover the entire derivative structure, but can be restricted to the root verb structure. This phenomenon confirms the claim in Nikanne (1998) that the root verb structure is a separate subunit of the LCS of the causative verb.

The discussion in this chapter raises further questions about the interaction between temporal, causal and agentive relations. Is the type of causative subordinate relation determined by the main verb? Is the first causation of the CSD always a launching event in cases where the scope of a causative adjunct is restricted to the root verb structure? What kinds of restrictions do features like control, volitionality, responsibility and awareness place on properties of causation? I leave these questions on the temporal relations of CSDs for future research.

## 5 CSDs and constructions

### 5.1 Social conceptualization as a source for construction building

Some of the CSDs analysed above already point towards morphological causatives possibly having individual features that are distinctive in relation to their compositional meaning (recall for instance the analyses of *pyöräilyttää* ‘make s.o. cycle’ and *tapattaa* ‘make s.o. kill’). There are different reasons for idiosyncrasy, such as the effect of a root verb’s individual characteristics or the contribution of the nominal arguments with which derivatives actually occur. In this chapter I will examine spread irregularities: patterns adapted by more than one CSD. In most cases, these patterns occur in addition to prototype-based use in connection with concrete verbs. The number of verbs occurring in the idiosyncratic models is, however, restricted. I will explore the idiosyncratic alternations in which CSDs occur by means of conceptual semantics analysis and observations based on language use. My aim is to examine factors beyond root verb semantics and the derivative mechanisms that influence the behaviour of CSDs. The salient semantic property of these derivatives, the conceptualisation of human social relations, also plays an important role in constructional phenomena.

Within linguistics, the term ‘construction’ can refer to a structure in general or to specific formations. The study of verb meaning in correlation with its sentential meaning has been the object of exploration of the *Construction Grammar* framework (Fillmore 1988; Fillmore and Kay 1996; Kay 1995; Kay & Fillmore 1999; Goldberg 1995; Östman & Fried 2004), a linguistic theory initially developed from *Case Grammar* (Fillmore 1968). The understanding of the nature of grammar in this approach is based on the idea that there are grammatical phenomena other than the purely lexical entries added to sentences. The recognition of irregular phenomena has led to the formulation of constructions as form-meaning correspondences independent of the lexical items that instantiate them, existing in parallel with the verbs. Fried and Östman (2004: 22) emphasize the non-compositionality of a constructional pattern in the interaction between lexical components and the larger construction they occur within. The weight of the semantic properties the words contribute to and the modifying influence of the construction on these properties (as well as the constructional features the pattern adds to the whole) should be recognised. Thus, the interpretation of a construction is seldom just the sum of its parts, but a complex combination of regular and irregular arrangements. The basic idea of construction grammar is that a proper language description should account for “the entirety of each

language”, comprising the general and idiomatic patterns of a language (Kay & Fillmore 1999: 1).

In this study I go by the assumption of construction grammar that a construction represents a form-meaning relation that is not directly derivable from general principles. Unlike the general treatment by construction grammar of the function and form of a linguistic expression as inseparable from each other (see Östman & Fried 2004), I examine constructional patterns within the modular framework of conceptual semantics and consider syntax and conceptual structure as systems of different representations. In particular I strive for a specification of the components of conceptual structure leading to idiomaticity in connection with CSD constructions.

As briefly discussed in chapter 2, the term ‘construction’ in my study refers to an exceptional linking relation between the subsystem of a representation in respect of default (rule-based) linking. This is in line with the assumption supported by Nikanne (2005) that there are methodological advantages in keeping basic linking apart from exceptional construction-based linking by assuming default cases of linking and irregular cases<sup>43</sup>. In this view, construction-based linking is based on mapping particular kinds of fragments of syntactic and conceptual structures; in addition, the constructional patterns often refer to particular words and morphological forms or add pragmatic information (ibid. 235). Thus, this approach acknowledges the relevance of constructions in an integrated account of language, also recognizing the existence of productive rules. Encompassing both kinds of phenomena i.e. the determination of regularities and irregularities in grammar is seen as the goal of formal description.

However, in order to define an aberrant phenomenon, the general principle it deviates from must be defined. The non-compositionality occurring within CSDs raises questions about the function of the *ttA*-morpheme, since it is the shared formal property of CSDs. Does the *ttA*-suffix have an independent invariant meaning? How can we define causative constructions? I assume that CSD prototype templates function as a generalised feature combination common to CSDs with their regular linking patterns. Thus the prototypes defined in section 3.4 represent the default linking formation of a CSD. The analysis in this chapter will be a touchstone for CSD prototypes in the sense that variation from the prototype structure

---

<sup>43</sup> This is an opposite view to the constructionalist approach, such as Croft’s (2001: 362), where constructions are treated as basic units of grammar: “The only type of primitive grammatical units are constructions – pairings of form and meaning which may be atomic or complex, schematic or substantive.” Also, Goldberg (2006: 5) presents a broad view of the weight of constructions in language in her definition: “Any linguistic pattern is recognized as a construction as long as some aspect of its form or function is not strictly predictable from its component parts or from other constructions recognized to exist. In addition, patterns are stored as constructions even if they are fully predictable as long as they occur with sufficient frequency.”

gives us a lead in defining constructional patterns. Supposing the relation in a prototypical case between the two human participants in a CSD situation is neutral, does an exceptional social environment have an effect on the idiosyncratic behaviour of these causatives? My hypothesis is that social causation exposes us to special nuances in the meaning describing the relationship between the human participants. These particular nuances add information to the situation described in a CSD proposition that is not predictable from the default case to the ‘regular meaning’. These extensions from the default proposition are identified in this study as constructions.

The hypothesis of constructional extensions above is based on the assumption that the character of social relations may be a source of significant lexical information. Jackendoff (1992a) supports the idea of a separate (possibly innate) module of mind for social cognition, the task of which is “to develop an integrated picture of the self in society”. He compares the social domain with spatial relations: whereas spatial representation deals with physical objects in space, the units of social representation are people in social interaction. The primitives operating within the social domain can, in principle, be seen as a range of *potential* features in the sense that there is a universal set of primitives, the same for all languages, combining in different ways in different languages. Basically, this idea can be likened to the distinctive features of phonology: there are subsets of all possible primitives, of which no language uses all features, but certain specific combinations of them. Thus, the actual subsets are language-specific.

The emphasis in the study below is on the relationship between the participants in a CSD situation, which may alert us to how Finnish reflects social dominance hierarchies in verb meaning and language use. The analysis in this chapter can therefore be seen as an attempt to test the social representation hypothesis by examining the nature of social causation. The main questions related to this topic are the following: what is the nature of the concept of causative verbs with two active, normally human, participants? What is the architecture of social representation – does it have primitives of its own or does it consist of fragments of other representations? What kind of features are significant, and what is their nature (primary/privative features)? What are the social implications that affect idiosyncrasy? How can we link social concepts to conceptual representation?

In Goldberg’s (1995) approach to the argument structure of a verb and its ability to occur in several different alternation patterns, a special subclass of constructions stored in a language, ‘argument structure constructions’, are assumed. In this view, the verb is not seen as a relation of empty slots filled with the exact number of arguments of the correct type; instead, the arguments provide the verb with a new sense as a consequence of every single syntactic configuration (ibid.11-12). The focus in this chapter is directed towards the phenomenon where the verb sense is modified not as a result of a change in syntactic realization and argument-linking on

morphoroles, but as a consequence of conceptual and pragmatic aspects. What launches this change? I argue that a possible explanation may be that the contextual influence rising from interaction causes changes in conceptual structure leading to constructional patterns. This creates ‘patterns of interpretation’, meaning that there are sets of interpretations stored for certain situations.

The constructions discussed in this chapter will thus unite semantics, linguistic form and pragmatic information. The idiosyncratic alternations raise the question of their consequences for the organization of lexicon. How is verb meaning related to its sentential meaning? What is encoded as lexical information? What is the nature of the patterns that allow different CSDs to behave in similar way? The discussion in sections 5.2-5.3 will concern the role of social phenomena like dominance, activity, responsibility and control in the construction-forming of causative derivatives. I will also strive to outline the impact of constructional patterns on the CSD verb grouping in section 5.4.1. Preliminary observations about the text-linguistic aspects related to these phenomena will be discussed in brief in section 5.4.2.

## 5.2 Power Misuse Construction and ‘bossy’ causatives

### 5.2.1 CSDs with motion verbs as root: the case of *juoksuttaa* ‘make s.o. run’

My study of idiosyncratic patterns in connection with CSDs begins with a type of verb that is exposed to a special dominance reading. In the previous section, the conceptualization of social relations was compared to the understanding of spatial relations. Obviously, CSDs derived from motion verbs are a combination of both kinds of relations. The people that the key arguments SAR and SAD refer to interact with each other and, at the same time, are objects in the spatial space. In a typical case, one of them (the SAR) is moving and the other (the SAD) is not. The motion of the SAR is explicitly caused by the SAD via social interaction. These are the optimal surroundings for a power balance between the people in a spatial situation.

I will start my investigation with a CSD that has a basic motion verb as a root: the verb *juoksuttaa* ‘make s.o. run’. This verb was also discussed in connection with the syntactic analysis of CSDs in chapter 3 and the temporal analysis in section 4.3.3. Pajunen (2001: 198-200) specifies the meaning of *juosta* ‘to run’ as a motion performed with one’s own force proceeding along a path from one place to another. Pajunen (1988) defines the semantic role of the only +animate argument of motion verbs with one argument place in their lexical entry as agent or theme. As discussed in section 4.3.3 in connection with the verb *juoksuttaa*, motion in this study does not equate to causation; the thematic role of the mover argument in the conceptual structure of *juoksuttaa* is analysed as the theme (assigned by the event-function ‘go’ in

zone 2) and the activity is determined in the action tier. The conceptual structure of *juoksuttaa* and the linking of thematic arguments to morphoroles is given in (1).

(1) [v [v juokse]j ttA]i

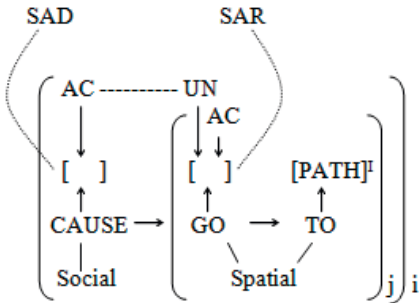

As we can see in the configuration of (1), *juoksuttaa* has one ‘cause’-function in its LCS, whose argument is the causer of the situation *j*. The structure in (1) corresponds to the objective actor prototype of a single-causative (PT2.2, see section 3.4). The causer argument is linked to the SAD. The theme argument is assigned by the function GO and is linked to the SAR; GO is an event-function, whose second argument is a PATH, and the theme argument is moving along that path (Nikanne 1990). Also, the action tier configuration corresponds to the prototype structure: the theme argument (SAR) is at the same time both the undergoer for the whole derivative structure and the actor of the root verb structure. Furthermore, the only possible undergoer of the upper action tier chain in this structure is the theme argument. Thus, unlike the verbs of double-causative CSD prototypes, there are no other potential arguments in the LCS of *juoksuttaa* that could assign the function UN. Note also that the actor in the lower action tier chain has no undergoer towards which to direct the domination. Because of the double-rolled configuration in the action tier, the room for power conflict is quite obvious.

I suggest that in the case of CSDs derived from motion verbs, the dominance relationship can be lexicalized in a specific way. In a situation where the SAD causes the motion of the SAR and the SAD is not involved in the activity, a ‘power abuse’ meaning is triggered in the CSD proposition. In formation of this meaning, different aspects of the LCS play a part. The activity of the participants and the form of influence both on the causation and the action tier level form part of the implications on the meaning. On the other hand, the spatio-temporal aspects influence the interpretation as well (as investigated in more detail in section 5.2.2 above). Consider an example with the verb *juoksuttaa* ‘make s.o. run’ in (2):

- (2) *Tom juoksuttaa Mattia*  
 Tom run-caus-pres-3sg Matti-part  
 'Tom is running Matti around.'

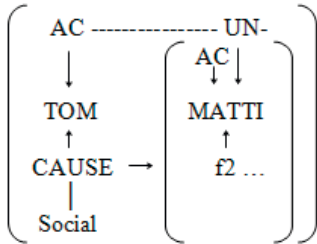

The meaning of the sentence *Tom juoksuttaa Mattia* thus includes an extension of spatial relations; the situation in (2) focuses on the social relationship between the participants. Because of this, I do not specify the semantic field of the core zones. The zone 2 function is marked with an unspecified f2; this does not determine the activity of the SAR. What characterises the activity of the human participants? The dominance between the two animate arguments is described in the action tier. Comparison to the general description of the verb *juoksuttaa* (see (1)) shows that the action tier of structure (2) differs in that the undergoer has the subrole of 'malefactive'. This subrole is assigned by the function UN- when the domination of the actor has a negative effect on the undergoer (see Nikanne 1995 & 2005). The specific characteristic of this kind of structure is that the theme argument MATTI assigns the action tier roles malefactive and actor.

I argue that the negative dominance reading of the sentence in (2) is activated by a construction that I call the 'Power Misuse Construction' (hereafter: PMC). The conceptual structure of the PMC is given in (3):

- (3) Power Misuse Construction

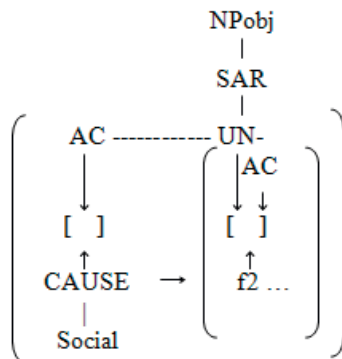



Construction (3) indicates that the SAD referent controls the activity of the SAR referent and that the SAR is performing the action in vain. The background of the interaction between the two actors is described in the social semantic field. Because of the SAD's misuse of the dominant position over the SAR, the undergoer of the construction is a malefactive and the construction expresses negative social dominance. The verb *juoksuttaa* 'make s.o. run' does not refer to the motion denoted by the root verb activity; the meaning is rather 'to run s.o. around'.

The PMC supports the assumption that the reach of the influence of the semantic field covers the whole zone (Nikanne 1990). In structure (3), the causation and the dominance of the first actor have the same cognitive background. The influence from one participant to another is rooted in social interaction, from which both the causation and the dominance are derived (Paulsen 2005). Hence the force or energy described in the power use situation can be investigated on two different levels in the conceptual structure: domination and causation. The social semantic field shared by the action tier and the causative function is a premise leading to the power abuse interpretation. The PMC is characterized by an expression of negative social dominance: the referent of the SAD is misusing its dominant position over the referent of the SAR. A premise for the arising of the social semantic field on the action tier level is that the main arguments of the structure (referents of the SAD and SAR) are +animate. The influence of the SAD over the SAR has a social (communicative) nature.

An aspect strengthening the power abuse meaning is the *futility* of the SAR's activity. Doing something in vain means that the activity the SAR performs does not lead to any meaningful or reasonable result. The SAR's suffering launches the malefactive reading. (The effect of futility on the PMC interpretation is investigated in more detail in subsection 5.2.2.) Another aspect of the meaning of this construction is that the SAD could prevent the pointless activity of the SAR but does not do so.

Additionally, the non-participation feature of CSDs i.e. the indirect social causation property contributes to the power misuse interpretation. When interpreting a CSD proposition, the referent of the SAR performing the action alone leads in some circumstances to the question: why is the SAD not taking part in the activity? In an experiment (Paulsen 2004) where the subjects were asked to assess the acceptability of 20 sentences with different causatives and to paraphrase the propositions, some of the subjects interpreted the SAD's behavior as insolent. The action of the SAD was regarded as flying in the face of certain social values and conventions that a responsible member of society should follow. The test subjects expressed disapproval of CSD situations in which the SAD did not participate in the action. This tendency was even seen in cases where the background to the situation was neutral and the social relations were of an ostensibly transparent nature (for instance in a sentence with the verb *haetuttaa* [fetch-caus-caus]: *Hovimestari haetutti*

*tarjoilijalla ruokalistan* – ‘The head-waiter ordered the waiter to bring the menu’). The disapproval of the power abuse situation was apparently the reason why the subjects also marked some completely comprehensible sentences as ungrammatical.

What forms part of the lexical meaning of *juoksuttaa* ‘make s.o. run’? According to NS, The Dictionary of Modern Finnish, *juoksuttaa* is a polysemous word with three main submeanings. The pointless activity – the power misuse reading – is one of them. The second submeaning is ‘let flow a substance or a more abstract entity’, and the third is focused on a theme carried to an endpoint. Consider these meanings using examples given in NS:

1. Have/make s.o. run:  
*Miehiä juoksutettiin kilpailussa kierros liikaa.* ‘The men were made to run one lap too many.’  
*Juoksutti alinomaa lääkäriä luonaan.* ‘He had the doctor constantly running to him.’
2. a. On liquid, fine-grained substance:  
*panna virtaamaan t. pitää virtaamassa, valuttaa, vuodattaa* ‘let run (water), flow, slide’  
 b. On thread etc.  
 c. ‘Let one’s fingertips glide (dance) over the keys’
3. ‘Speed, hurry’  
*Juoksuttaa kirje postiin, lapset saunaan* ‘run a letter to the post office, usher the children into the sauna’

In comparing the dictionary itemization of *juoksuttaa*, I have counted the submeanings of it by analysing the first 100 results on Google. The analysis gives a rough indication of the distribution of the senses, without taking into account the variability of text types and genres. As is characteristic of extensive online material, not all of the results were valid regarding the purpose of the task: 16 hits out of 100 were irrelevant (repeatedly occurring hits, hits from translators and in the case of some results the meaning was impossible to determine). The outcome of the analysis is presented in Table 1 (irrelevant hits not included):

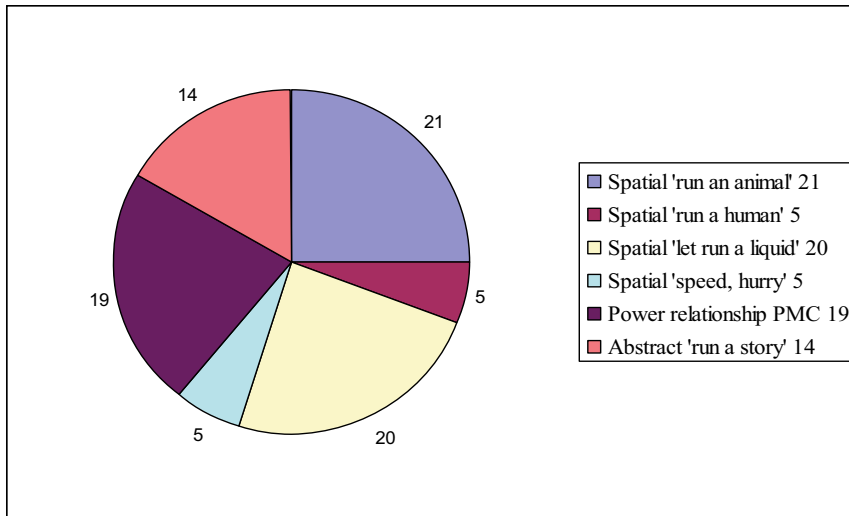
Table 1. 100 results of *juoksuttaa* ‘make s.o. run’ from Google<sup>44</sup>

As we can see, a fifth of the cases (19) bear the power misuse denotation. 20 denote ‘letting flow a liquid’. Only 5 cases denote the third submeaning given in NS, ‘speed, hurry’. Additionally, I separated a group of examples with the spatial productive meaning of ‘letting s.o. run’ (neutrally i.e. without a power misuse implication). Here I distinguished between 21 examples with SARs referring to an animal and 5 examples with a human SAR referent. All of the power misuse examples have human SAR referents. The abstract ‘run a story’ (14 cases) corresponds to the NS submeaning 2c. Note also that the form *juoksuttaa* stands for both the infinitive and the 3<sup>rd</sup> person singular. To illustrate the investigated online material, I will give two examples of the PMC reading ((4) and (5)) and two with neutral spatial utterances ((6) and (7)).

(4) *juoksuttaa* [run-caus] ‘make s.o. run’

*Moni jättää Euroopan matkoiltaan kengät ostamatta, kun pitää istua palveltavana ja juoksuttaa myyjää kenkä kerrallaan takahuoneen varastoon etsimään sopivaa kokoa ja sopivaa väriä.*

‘Many people avoid buying shoes on European trips because you have to sit and be served and **make** the salesperson **run** one shoe at a time to the back room to find the right size and right colour.’

([http://www.talentum.com/doc.do?f\\_id=712145](http://www.talentum.com/doc.do?f_id=712145))

<sup>44</sup> The search was conducted on 3 May 2005; the total number of hits returned for *juoksuttaa* was 683.

- (5) *Mielestämme olisi törkeää ja epäoikeudenmukaista juoksuttaa sairaita ihmisiä muihin terveyskeskuksiin, joissa jo nyt on ruuhkaa ja pitkät jonot.*  
 ‘It is, in our opinion, outrageous and unfair to **make** sick people **run** to other health centres that are already backed up with long queues.’  
 ([http://www.hel2.fi/Terveyskeskus/suomi/hallinto/terveyslautakunta/esityslistat/200205\\_07\\_el.htm](http://www.hel2.fi/Terveyskeskus/suomi/hallinto/terveyslautakunta/esityslistat/200205_07_el.htm))
- (6) *Koira juoksuttaa omistajaa* (headline, G.P.). *Ulkoiluttamista koira kaipaa kolme kertaa päivässä, joten ei liene ihme, että kansainvälisten tutkimusten mukaan koiranomistajilla väitetään olevan harvemmin terveysongelmia ja pienempi sydäntautien riski kuin koirattomilla ihmisillä.*  
 ‘Dog **makes** owner **run**. Dogs have to be taken for walks three times a day, so it is no wonder that dog owners claim to have fewer health problems and are at a lower risk of heart disease than non-dog owners.’  
 (<http://www.hs.fi/omaelama/artikkeli/HS20040531SIITL01qim>)
- (7) *Ottelutahti on tosin sen verran tiivis B:n sarjassa, että 90 minuuttia ei junnuja ole lupa juoksuttaa.*  
 ‘The pace of the game in B-division is so fast that it is not allowed to **have** the juniors **running around** for 90 minutes.’  
 ([http://www.tups.fi/mp/db/file\\_library/x/IMG/11830/file/puiutups\\_ennakko.doc](http://www.tups.fi/mp/db/file_library/x/IMG/11830/file/puiutups_ennakko.doc))

### 5.2.2 Strong and weak PMC: modifications of the Power Misuse Construction

In this section I will focus on the aspectual variations of the PMC and the role of the spatiotemporal component in the meaning of the construction. Consider these sentences:

- (1) *Tom runs to the park.*
- (2) *Mary is running.*
- (3) *Bill is running around.*
- (4) *Susan is running in the park.*

Motion verbs like ‘to run’ express both movement in a direction and movement within a place, as e.g. Pajunen (1988) shows. In the lexical structure of ‘run’ the direction of the activity is in most cases addressed to the end-point of the route (as in (1)). This end-point indicates that there is a change involved in the proposition – at the beginning of the running Tom is in an unspecified place, and at the end of it he is in the park. Sentences (2-4) also express activity, but there is no end-point of the action and thus no

change involved. Depending on the modifiers, either the motion itself (2) or the location of the activity (3-4) is expressed.

In Finnish, the distinguishing aspectual means are the object case marking and spatiotemporal features of the root verb; these also modify the meaning of derivatives. Compare the following sentences:

(5a) *Vanhemmat juoksuttavat poikansa viulutunneille.*

parent-pl run-caus-pres-3sg son-acc-px3pl violin.lesson-pl-all  
‘The parents run their son to his violin lessons.’

(5b) *Vanhemmat juoksuttavat poikaansa viulutunneilla.*

parent-pl run-caus-pres-3sg son-part-px3pl violin.lesson-pl-ade  
‘The parents are running their son around making him take violin lessons.’

(6) *Tämä napero juoksuttaa vanhempiaan ympäriinsä.*

that kid run-caus-pres-3sg parent-pl-part-px3sg around-ill-px3sg  
‘That kid is running his parents around.’

The goal and end-point of the route in propositions (5a, 5b) is ‘violin lessons’. This implies that there is a result or a purpose to the activity. Without a goal or end-point, as in (6) it is hard to find any purpose or meaning in the activity. The only purpose seems to be the power struggle between the child and his parents. The motion denotation is here distanced further from the original meaning – there is a (repetitive) activity, but not in the direct meaning of ‘running’. Spatial denotation in (5a-b) is present as moving from one place to another or moving within a place. In the example in (6), on the other hand, the ‘motion’ does not necessarily mean a psychical action at all, but rather a psychological one: the parents are giving in to their children’s nagging. Common to examples (5-6) is that there is a clear domination order, with the SAD controlling the situation and the SAR acting/moving as the SAD intends. The object case marking of the SAR also modifies the completedness of the situation. The accusative *poikansa* [son-acc-px3pl] in (5a) indicates a bound event, whereas the partitive *poikaansa* [son-part-px3pl] in (5b) indicates an unbound event (see Nikanne 2006 regarding the Finnish object case marking; this topic is also discussed in section 3.1.1). Another remark on the object case alternation in these examples is that in (5a) the object can in principle assign both the accusative and partitive case; the accusative refers to a single event while the partitive indicates a continuous situation. In (5b) and (6), the only possible object case is the partitive.

Levinson (2003) points out that “motion is naturally more complex than location, because it involves the extra temporal dimension”. The temporal aspect seems to have a role in the meaning of the LCS of causatives derived

from motion verbs as well. Moving along a path also ends on the temporal level with the end-point of the path, if there is any. Without reaching the goal, the activity is ongoing until an uncertain point of time. In both cases it is still a question of activity, not a state. Pajunen (2001) explains deviation within a process via the notion of change: a process typically expresses a change in state of a being, or an event (activity) that does not lead to an (instant) change.

The study of Kainlauri (2005) indicates that most verbs with illative case valence in Finnish express change. According to this study, one of the functions of the illative is to indicate force dynamicity between a stronger and a weaker antagonist in Talmy's (1988) terms, and moreover, the 'force dynamic' use of the illative always includes a motion component. The force dynamic phenomenon is also an indication of causation. In such cases, the spatial expression can partly share the causative meaning of the proposition. An expression in the illative focuses particularly on the end-point of a route, as does the allative case in Finnish. The examples above display even more complex configurations. The sentence in (5a) is an example where the goal of the theme's transition assigns the allative case [violin.lesson-all], and sentence (5b) with the goal in the adessive [violin.lesson-ade]. These bidirectional motion expressions seem to adjust an analogical dynamicity between the antagonists as the illative. Note that in (6), the lative adverbial *ympäriinsä* 'around' (around-ill-px3sg) in the illative is an exception to the direction-related result: this is a frozen form that does not occur in other cases or without the possessive suffix, and encodes a rather endless activity. Thus, in addition to the resultative denotation, there is a nuance of frequentativity in the semantics of verbs like *juoksuttaa* 'make s.o. run' and for instance *hyppyttää* 'make s.o. jump', indicating a repetitive activity.

The repetitive nature of the SAR's activity is present in (5b), whereas in example (6) the activity can be characterized as continuous. Consider sentences (5a-b), where 'violin lessons' are the goal of the activity and partly the motivation of the motion. There is no such motivation for the action in (6), since the activity is ongoing without an end-point. I would argue that an ongoing activity without a goal emphasizes the futility of the action. The presence of a goal also has an effect on the construction level. The PMC has its strongest effect in sentences where there is no end-point in the structure and subsequently no change in the situation (e.g. 'run s.o. around'). On the conceptual structure level, change is assumed to be present if both the feature [direction] and the time-node are present, which is expressed by the following rule (D = direction and T = time-tier) (Nikanne (1990: 56-58)):

D + T = change

According to Nikanne (1990), the function GO indicates change, since it is an f2 with both a T- and D-node, and for example the function MOVE (a monadic event-function whose argument is undergoing some sort of activation) does not indicate change – it has a T-node but no D-node in its feature system. Apparently the LCS of the construction with *juoksuttaa* should reflect this distinction, as the presence of change affects the construction meaning. The LCS of *juoksuttaa* with the change notion is described in (7) and without the change notion in (8). I call them the ‘weak PMC’ and the ‘strong PMC’ respectively. The arbitrary goal argument in (7) is marked with the abbreviation ARB.

(7) Weak PMC

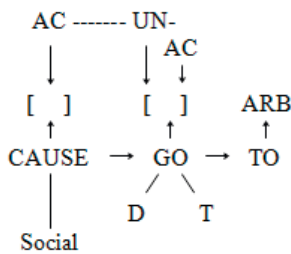

(8) Strong PMC<sup>45</sup>

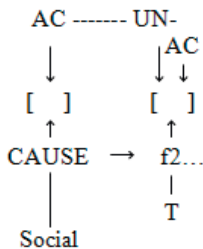

Hence, via the case selection of the locative expression and object marking, the grade of power abuse can be varied. An example of a weak PMC is (5a); a strong PMC is exemplified in (5b). The syntactic form of the sentences differs in the case marking of the locative as well as the object case marking. The allative case (ending in *-lle*) expresses the goal in (5a), and the adessive case (ending in *-lla*) expresses the location<sup>46</sup>. In comparing the

<sup>45</sup>Pörn (2004) marks a situation where the notion of time is irrelevant with the (habitual) HAB-operator, which describes a dynamic situation with a generic meaning (see Pörn 2004; compare with the PL-operator in Jackendoff (1991)). I am not sure if this operator can be used here, since for instance the situation in example (5a) could also be understood to be a habit.

<sup>46</sup>Both the allative and adessive cases in Finnish express external locatives. The LCS of the allative, according to Nikanne (1990), is ‘to’ ([ON ([ ])]) and the adessive ‘at/on’ ([ ]).

sentences, the power abuse meaning is stronger in (5b) than (5a). Sentence (6) is an example of a strong PMC, because the illative adjunct does not express the end-point in this particular case. The accusative object in (5a) expresses the bound and the partitive in (5b) the unbound situation. Thus, the variation of case markings of the SAR – atelic when partitive and telic when accusative – varies the grade of futurity when it comes to the utility and effectiveness of the action of the SAR. I will not go into greater detail regarding the accusative/partitive variation of the SAR here (for aspectual object case marking in Finnish see e.g. P. Leino 1991, Maling 1993 and Nikanne 2006).

### 5.2.3 Power abuse and different types of motion

Analysis of the PMC in the previous sections was based on the example of the *ttA*-causative with *juosta* ‘to run’ as the root, but the PMC phenomenon is not restricted to this verb. Based on my material, it is discernible that the CSDs disposed to the PMC are primarily verbs derived from roots denoting self-agentive motion like *kävelyttää* ‘make s.o. walk’, *tanssittaa* ‘make s.o. dance’ and *ryömittää* and *kontatuttaa* ‘make s.o. crawl’. Because of the special dominance relationship in their LCS, the verbs that occur in PMC can be called ‘bossy’ causatives (Paulsen 2005b). In this section I will discuss the different types of motion verbs in the PMC and how variation in root verb features may affect the power relation. What kinds of verbs apply to the PMC? Are there variations in meaning? I will also give examples from informal language use to explicate the spread of the PMC in different surroundings.

To start with, we can ask why CSDs derived from motion verbs in particular adapt the PMC. An important restriction is that the root verbs of bossy causatives are generally motion verbs that have the theme argument in motion. Consequently, this theme is an active, agent-like argument, maintaining the theme argument position even when derived as a CSD. In other respects, its position changes. As discussed in the previous section, the semantic field is not necessarily spatial and the action tier configuration adds another action tier role, the malefactive. Compare examples (1a-b): sentence (1a) emphasizes that there is a negative dominance relation and in (1b) the dominance relation is neutral. The negative dominance reading in (1a) is launched by the malefactive SAR (‘customers’). The syntactic realization of PMC sentence (1a) is not distinguished from the neutral dominance reading (1b), as the examples of *kävelyttää* ‘make s.o. walk’ show. Interestingly, the semantic field of the theme transition in the PMC example can also be spatial, as in (1a). The semantic field of causation is still social in (1a),



whereas in (1b) it is physical (the instrument physically makes the patient walk). The uses of *kävelyttää* do not syntactically differ in (1a) and (1b): both have the subject in the nominative and the object in the partitive.

(1a) *kävelyttää* [walk-caus] ‘make s.o. walk’

*Postin palvelujen parantamista ei ole, että Posti postinjakajien sijaan kävelyttää asiakkaitaan.*

‘It is not an improvement to postal services if the Post Office **has** customers doing the **walking** instead of the postmen.’

(<http://www.postiliitto.fi/ajankohtaista.htm>, 30.8.2005)

(1b) *Kävelysimulaattorikuntoutus on kuntoutusta, jossa pyritään elvyttämään alaraajojen toimintaa ja siinä käytetään apuna mekaanista laitetta joka suoraan sanoen kävelyttää potilasta.*

‘The goal of walking simulator rehabilitation is to restore the functioning of the legs, and a mechanical device is used here as an instrument that basically **makes** the patient **walk**.’

([http://www.yle.fi/akuutti/arkisto2004/261004\\_a.htm](http://www.yle.fi/akuutti/arkisto2004/261004_a.htm), 30.8.2005)

By way of comparison, consider these examples with the verbs *juoksuttaa* ‘make s.o. run’ (2), *pyörittää* ‘make s.o. spin’ (3) and *ryömyyttää* ‘make s.o. crawl’ (4).

(2) *juoksuttaa* [run-caus] ‘make s.o. run’

*Miten reagoit, jos säyseästä ja hymyilevästä naisesta tulee kiukkupussi, joka juoksuttaa sinua vähän väliä asioillaan ja itkee usein?*

‘How would you react if a shy, smiling woman turned into a furious monster who **was running** you **around** the whole time with her business and often crying?’

([http://www.soneraplaza.fi/ellit/artikkeli/0,2705,h-2091\\_a-0869,00.html](http://www.soneraplaza.fi/ellit/artikkeli/0,2705,h-2091_a-0869,00.html), 30.8.2005)

(3) *pyörittää* [spin-caus] ‘make s.o. spin’

*Tytöt osaavat pyörittää isänsä kyllä ostamaan kaikenlaista pehmolelua, tiimarikamaa sun muuta.*

‘The girls know how to **wrap** their father **round their little fingers** (spin him around) to buy them all kinds of cuddly toys, knick-knacks and things like that.’

(<http://www.eroperhe.net/keskustelu/index.php?topic=14755.0>, 30.8.2005)

(4) *ryömityttää* [crawl-caus-caus] ‘make s.o. crawl’

*Uhoajasta ei ollut enää mitään jäljellä. Oli vaikeaa kuvitella, että sama mies **ryömitytti** talvella joukkuettaan pitkin lumihankea aamulenkki päätteeksi.*

‘The bully had vanished. It was hard to imagine it was the same man who had **had** his team **drag** themselves through the snowdrift to get to the end of their morning run.’

([http://tariffi.blogspot.com/2004\\_07\\_01\\_tariffi\\_archive.html](http://tariffi.blogspot.com/2004_07_01_tariffi_archive.html), 30.8.2005)

Examples (2-4) incorporate a denotation of a repetitive and/or continuous activity. Even though example (3) indicates an end-point in the activity, expressed with the illative in the infinitive *ostamaan* ‘to buy’, the activity can be understood as habitual. The verb *kierittää* ‘make s.o. roll’ can be used in the same way as *pyörittää* ‘make s.o. spin’ in my data. All of the examples (2-4) match the strong construction variant i.e. the static PMC mentioned in the previous section, corresponding to the ‘move s.o. around’ notion. Example (4) has an ambiguous meaning; both the concrete spatial and abstract humiliation denotation are present. Note that the CSD *ryömityttää* incorporates two causative suffixes, which according to compositional productive expectations should add an additional actor to the primary curative proposition. The exploitation of the military hierarchy the situation in (4) refers to is the most probable for this reading, but it is not completely apparent if there is a subordinate actor giving orders between the bully and his team. Actual movement also seems to be present in the SAR’s activity in example (5) with *kontatuttaa* ‘make s.o. crawl on all fours’. Note that Finnish distinguishes between crawling with the whole body in contact with the ground (*ryömiä*) and crawling on all fours (*kontata*). Causations from the last verb, *kontatuttaa* and *kontauttaa*<sup>47</sup>, can be used as bossy causatives, too, in contexts similar to the example with *ryömityttää*:

(5) *kontatuttaa* [crawl-caus-caus] ‘make s.o. crawl on all fours’

*Itselläni on omakohtaisiakin kokemuksia eräästä yksikön väepelistä, jolla oli tapana **kontatuttaa** väkeä ulkojärjestymispaikalle kun hommat eivät sujuneet.*

‘I have personal experience of a certain sergeant major in a unit who was in the habit of **making** people **crawl on all fours** to the outside meeting place when things were not running properly.’

(<http://www.mountine.com/aamukampa/forum/viewtopic.php?p=3112>, 5.6.2005)

<sup>47</sup>For some reason, the simple causative derivative *kontattaa* does not occur in the material I have sought.

It is characteristic of verbs that the action denoted by the predicate is restricted by the manner or instrument in that they explicate the way in which the action is performed (Levin & Rappaport 1992). This may influence the reading of a bossy causative to some extent. Consider the interpretation of *kynittää* derived from the root verb *kyniä* ('to pluck'), which can have a serious power abuse meaning of deprivation or beating in a context of competition (compare example (6a) from a discussion with society as the topic and (6b) from a basketball discussion). The meaning of *kynittää* in (6a) might be figuratively seen as 'strip s.o. of their feathers', whereas in (6b) the verb denotes overpowering in a sports situation.

(6a) *kynittää* [pluck-caus] 'exploit s.o.; beat'

*Eräänlainen pienoisyhdistys, jossa ei tarvi huijata toisia eikä kynittää kun kaikki tietävät saavansa saman verran.*

'A kind of mini-society where there is no need to cheat others or **exploit** (take advantage of) them when everyone knows they get an equal share.'  
(<http://www.fi/reggae.com/read.php?f=10&i=14317&t>, 24.11.2005)

(6b) *Äänekoski kynitti aina meitä*

'Äänekoski always **beat** us.'

(<http://www.koripallo.fi/forum/index.php?board9>, 24.11.2005)

A more general verb-encoding relocating of the theme argument can also be used in the power abuse context. Consider the example with *poistuttaa* 'make s.o. exit', used as the military order 'move along', and also more generally as a marker of the ultimate power of the SAD:

(7a) *(taakse) poistuttaa* [(behind) exit-caus] 'make s.o. exit, move s.o. off/back/along'

*Saas nähdä kuinka Jokisen Olli venkoilee armeijasta. Olisi näkemisen arvoista, kun 18v alikessu poistuttaa miljonääri-päällikkö 30v Jokista.*

'We'll see how Olli Jokinen worms his way out of the army. It'd be interesting to see an 18-year-old corporal **moving along** the 30-year-old millionaire and manager Jokinen.'

(<http://keskustelu.jatkoaika.com/archive/index.php/t-14855.html>, 4.12.2008)

(7b) *Nokian Ollila käskee ja taakse poistuttaa ministereitä.*

'Nokia's (director) Ollila not only orders ministers around, but **gives** them their **marching orders**, too.'

(<http://portti.iltalehti.fi/keskustelu/post!reply.jsps?messageID=8581035>, 4.12.2008)

The spatial information of the root verb may thus modify the social reading of the PMC in terms of the strength or degree of abuse. How does spatial information translate into social information? The malefactive reading of the SAR affects the reading of the caused activity on the social relationship level, whereas each motion verb adds its properties and aspectual nuances to this activity. Nevertheless, verbs encoding different types of motion adjust the PMC structure and the focus is shifted to social dominance – the SAD is controlling the activity of the SAR, who has to perform the action. The influence of context affects the social reading. The use of bossy causatives also varies in terms of distribution regarding the register, topic or text type they occur in.

#### **5.2.4 CSDs other than causatives derived from motion verbs adapting the Power Misuse Construction**

The bossy causatives analysed hereto were derived from different types of motion verbs. However, there are causatives with other types of roots derived with the suffix *ttA* that are able to apply the PMC. They are also a source for further variations of the power abuse denotation. The semantic nuances of verbs that adjust to the PMC and their suitability in different contexts influence the PMC towards slight nuances. The goal of this section is to identify the variations and some of the surroundings of these verbs in actual use.

The relationship between the root and the derivative is not always unambiguous – word derivation is not necessarily based on directional chains and the combining of bases with suffixes, but on various analogies and correlations (see for instance Räisänen 1983 and Jääskeläinen 2004). There are two bossy causatives in my material that I interpret as denominal, although the root words include an aspect of activity: *kyykyttää* ‘make s.o. squat’ (< *kyykky* ‘squat’) and *hyppyyttää* ‘make s.o. jump’ (< *hyppy* ‘jump’). Of these two derivatives, *hyppyyttää* has a more complicated derivation relation. ISK (§323) notes that *hyppyyttää* is a variant of *hyppäyttää*, and classifies it as a deverbal verb, derived from the *AA*-verbstem classified as ‘contracted verbs’ (Fin. *supistumaverbi*); in this case the root verb would be *hypätä* (: *hyppÄÄ-*) ‘to jump’. However, the *UUttA*-derivatives are also associated with nominal derivatives with the *UUs* morpheme (see ISK §324), which again are often derived from nouns or adjectives; the root word is in some cases difficult to point out. Thus we can get following derivative chains:

- (1) a. *valtuuttaa* ‘authorize’ < *valtuus* ‘accreditation’ < *valta* ‘power’  
 b. *orjuuttaa* ‘enslave’ < *orjuus* ‘slavery’ < *orja* ‘slave’  
 c. *nöyryyttää* ‘humiliate’ < *nöyryys* ‘humility’ < *nöyrä* ‘humble’  
 d. *arvuuttaa* ‘make a guess’ < *arvaus* ‘guess’ (n) / *arvo* ‘value’/ *arvata* ‘guess’ (v) / < *arpa* ‘lot’ (etym. ‘the little (bone) item fastened to a shaman’s drum’ (SKE))  
 e. *toppuuttaa* ‘restrain’ < (possibly) the interjection ‘stop!’  
 f. *hyppyyttää* ‘make s.o. jump’ < ... < *hyppy* ‘jump’  
 g. *vakuuttaa* ‘convince, insure’ < *vakuus* ‘guarantee’ < *vakaa* ‘steady’

Examples (1a-g) show that directionality and derivation relations are not completely transparent when it comes to *UUttA* derivatives. There may be an empty step in the derivation chain or several candidates for the root word position, or contemporary language may lack the root word association. Another question is whether the interpretation of the derivation relation should be based on semantic or form-based elements; semantic derivative relations are emphasized by Räisänen (1979, 1983) and Kytömäki (1992). In the case of *hyppyyttää*, I consider the noun *hyppy* ‘jump’ to be a strong candidate for the root word besides the verb *hypätä* ‘to jump’, since the verb *hypätä* does not explain the *UU* element in the causative. Similarly, I assume that the verb *kyykyyttää*<sup>48</sup> is derived from the noun *kyykky* ‘squat’. Hence, in the analysis of the argument structure of *hyppyyttää* and *kyykyyttää*, we can conclude that the *UUttA* verbs are an irregular set, resembling each other in terms of the analogic derivational relationship.

In my material, *hyppyyttää* and *kyykyyttää* are used in quite similar senses: keeping the SAR referent carrying out a futile activity (see examples (2-4)). In (2), *hyppyyttää* and *juoksuttaa* are coordinated. In (3) I give another example with *hyppyyttää*, and in (4) with *kyykyyttää*. If possible, ‘making s.o. jump’ and ‘making s.o. squat’ seem to have an even stronger negative connotation than ‘making s.o. run’. Is this the case because of the more demanding physical task that the basic meanings of these verbs imply or is the activity they refer to more unconventional than running? In any case, the tone of power abuse is most cruel in (4).

<sup>48</sup>It is not obvious whether *kyykyyttää* is an *UttA*- rather than an *UUttA* verb only because of phonological reasons. There are different views in the analysis of the (reflexive) derivative element *U* in terms of whether and which semantic content it takes in suffix combinations. According to Karlsson (1983), autonomous suffix components should only be assumed when there are semantic grounds to do so, which produces for instance the components *totu+tta+utu* for *totuttautua* ‘get used to s.t.’, not *totu+tta+u+ta+u*.

- (2) *hyppyyttää* [jump-caus] 'make s.o. jump' and *juoksuttaa* [run-caus] 'make s.o. run'

*Palvelu on yrmeätä vastaanottovirkailijasta lääkäriin. Tuntuu, kuin päätarkoitus on hyppyyttää ja juoksuttaa asiakasta.*

'The service is unfriendly from the receptionist to the doctor. Its main purpose seems to be to **make** the patients **run** and **jump** through hoops.'  
(<http://www.otakantaa.fi/forum.print.cfm?group=174>, 30.8.2005)

- (3) *hyppyyttää* [jump-caus] 'make s.o. jump'

*Asiakkaina on välillä todella ikäviä heikkoitsetuntoisia ihmisiä, joiden suurin nautinto on hyppyyttää lentoemäntää mitä pikkumaisin asioin.*

'Sometimes you have customers with very low self-esteem whose greatest pleasure is to **run** the stewardess **around** doing the most trivial things.'  
(<http://www.iltasanomat.fi/keskustelu/lukijanviesti.asp?id=1299006>, 5.6.2005)

- (4) *kyykyttää* [squat-caus] 'make s.o. squat'

*Kaiken piti jatkua hyvänä ja parempana ikuisesti, mutta hyvinvointivaltiota tulikin 1990-luvulla vähemmän antelias. Se moralisoi ja kyykytti köyhiä. Se vaati työkuria, itsekuria ja säästämistä. Se korosti jokaisen omaa vastuuta.*

'Everything was supposed to go on getting better forever, but the welfare state became less generous in the 1990s. It moralized and **bossed** the poor **around** (= made the poor squat). It demanded work discipline, self-discipline and frugality. It emphasized everybody's individual responsibility.'

(<http://www.stakes.fi/dialogi/01/dia20013/30114b.htm>, 22.3.2006)

As we can see, *hyppyyttää* and *kyykyttää* can be used in the PMC. The (spatial) feature that the PMC verbs discussed hereto have in common is that the root word expresses self-agentive motion or even a spatial configuration. Where do verbs derived from motion verbs diverge? The verb *juosta* 'to run' encodes a motion along a (horizontal) path; *hypätä* 'to jump' and *kyykky* 'to squat', however, do not. The last two lexemes express upright motion or a change in the position of the body and/or limbs. Does the more demanding task imply more painful humiliation and facilitate the formation of the disapproval view? There seems to be some reciprocity between the levels, since spatial features can affect the character of social relations.

However, there are other denominal *ttA*-causatives that adapt the PMC; examples (5-7) with the verbs *pompottaa*, *pellottaa* and *penkittää* are associated with the strong PMC. Note that the theme argument is an actor in examples (6) and (7), corresponding to the PMC structure. This is somewhat

unclear in example (5). Examples (5-6) correspond to the meaning ‘boss around’ or ‘run around’. *Penkittää* in example (7) is not a typical PMC verb, but has an association with the dominance relation typical of the PMC. This verb can be used in contexts where a player on a team is kept on the bench; the fact that he/she is not allowed to play is experienced as a social punishment and an embarrassment. The translations of the examples reveal the variety of types of dominance.

(5) *pompottaa* [bounce-caus] ‘walk over, run around’

*Hallituksessakin on jo totuttu siihen, että Paperiliitto ja muutamat muut vientiteollisuuden avainliitot **pompottavat** koko työmarkkinakenttää viimeiseen saakka. Se ikään kuin kuuluu pelin henkeen.*

‘Even the government has accustomed itself to the fact that the Paper Union, and some other key unions, **walk all over** the labor market to the last. It is sort of part of the spirit of the game.’

(<http://www.turunsanomat.fi/kotimaa/?ts>, 24.4.2007)

(6) *pallottaa* [ball-caus] ‘walk over, run around’

*Fysiatrini kätteli, että ei jalat toimi sekä ovat tulehtuneet ja **pallotti** takas reumatologille jne. Tätähän tää on ollut.*

‘The physiotherapist saw that my feet weren’t working and had become inflamed and **sent** (bowed) me **back** to the rheumatologist. That’s how it’s been.’

([http://www.verkkoklinikka.fi/discussion/browse\\_messages\\_cust.xsp?group ID=36](http://www.verkkoklinikka.fi/discussion/browse_messages_cust.xsp?group ID=36), 16.12.2008)

(7) *penkittää* [bench-caus] ‘make a player sit on the bench’

*Menneellä viikolla seuran puheenjohtaja Roman Abramovitsh paljastui Venäjän rikkaimmaksi henkilöksi 14,1 miljardin omaisuudellaan. Chelseaalla on siis varaa **penkittää** myös tulevaisuudessa miljoonamiehiään.*

‘Last week the chairman of the club was revealed to be the richest person in Russia, with a fortune of 14.1 billion. Chelsea will thus be able to afford to **have** their million-pound players **sit on the bench** in future, too.’

([http://www.futismaailma.com/liigat/tv\\_ennakko.php?oid=26](http://www.futismaailma.com/liigat/tv_ennakko.php?oid=26), 24.4.2007)

### 5.2.4.1 Power and competition

In this section I will discuss some further subcategories in connection with the PMC. I will start with the CSD that was brought up in the previous section: *kyykyttää* ‘make s.o. squat’. It should be noted that the English ‘to squat’ does not encode motion at all, but a configuration state (Nikanne 1990, 16). In Finnish, the verb *kyykkiä* can denote, in addition to the configuration meaning, ‘to move whilst in a squat position’ or ‘to squat on one’s heels’ and the inchoative verb *kyykistyä* means ‘to squat (down)’; the noun *kyykky* ‘squat’ denotes the configuration state. The meaning of the derivative *kyykyttää* seems to be, figuratively, ‘to make s.o. adopt an uncomfortable position and remain in it’. Movement into the configuration thus implies a motion component; therefore, I analyse the zone 2 function of its conceptual structure as ‘go’ and not ‘conf’ (the thematic function denoting configuration and selecting the theme: see 2.2.1) in conceptual structure (2).

The bossy causative *kyykyttää* ‘make s.o. squat’ shows an interesting tendency that is absent in ‘make s.o. run’ and ‘make s.o. jump’. This verb can have a resultative denotation of ‘total beating’ in describing competitive situations where somebody comes out as the winner. The SAD is then the ‘winner’ and the SAR the ‘loser’. The dominance structure can be visualised as a vertical hierarchy: as a result of the competition, the winner is on top and the loser underneath. The malefactive-actor SAR, at least in the competition examples, is more active than in the dynamic PMC in general. The ‘loser’ is expected to and does provide resistance in the competitive situation; there is a real attempt to ‘fight’ the winner. After all, to be able to beat somebody, there has to be a juxtaposition. Consider this example of *kyykyttää* in the resultative (contest) meaning in (1):

(1) *kyykyttää* [squat-caus] ‘make s.o. squat’

*Suomi kyykytti puolivälierässä Ruotsin 2-1*  
 ‘Finland **beat** Sweden 2-1 in the semi-final.’  
 (sfnet.urheilu.jaakiekko, 13.5.2005)

The conceptual structure of sentence (1) is analysed in (2). For the competitive situation sentence (1) describes, I introduce here the semantic field ‘competition’. I suggest that this field is needed to describe the special situation between the opposing participants (i.e. FINLAND and SWEDEN in (2)) pursuing the same goal. The competition field can be seen as a type of social causation. An important semantic feature in the competitive situation is the intentional activity of the causer argument; therefore, the semantic feature ‘intentional’ (int) is added to the CAUSE-function in (2). Losing a competition is generally considered as embarrassing, which contributes to the malefactive reading of the SAR (SWEDEN). An additional feature of competitive causation is that it is not indirect causation: both actors are



actively participating in a competitive situation in which one of them will be beaten.

(2)

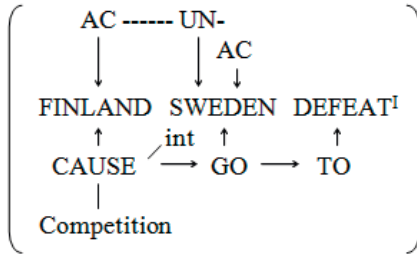

The structure in (2) differs to some extent from the description of the PMC. I assume this structure to be a subconstruction of the PMC: let us call it the ‘defeat PMC construction’. The conceptual analysis of this construction is given in (3). The difference here to the regular PMC as defined in section 5.2.1 lies in the specified zone 1 argument (the implicit goal argument DEFEAT) and in the cognitive background to the causation, which is the competition. The theme argument SAR thus experiences a transition to the status of the defeated and is ranked as the loser in the competition situation. Similar to the PMC, the SAR argument is assigned the action tier role malefactive as well as the actor of the lower action tier. Unlike the ordinary PMC, in the case of the defeat PMC, the SAR is aware of the humiliation; we will return to the question of awareness in section 5.2.6.

(3) Defeat PMC

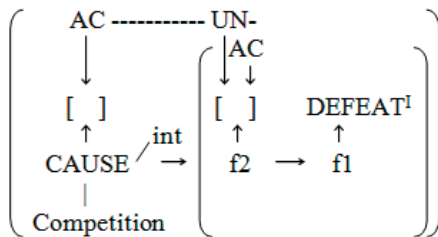

In section 5.2.2 it was argued that in continuous situations where the activity of the SAR has no spatial or temporal end-point and there is no change in the situation, the grade of power abuse has a stronger implication than in dynamic situations where the activity of the SAR is directed to an end-point. In addition to these aspectual characteristics, the verb encoding spatial information can be influenced by other semantic nuances as well, depending e.g. on the bodily position or configuration that the root word

encodes. Naturally, the original spatial meaning in the social dominance situation is blurred. In a power misuse context combined with a competition situation, the combat between the two parties results in one party suffering defeat. In (3) this means that the SAD has beaten the SAR. If the result of the activity is that the SAR is defeated (and the goal argument is DEFEAT), the effect on the SAR is to make them desolate and the power misuse implication is strong. Thus, the strong-weak PMC variation does not affect the defeat construction.

In (4-9) I give more examples of causatives that apply the defeat PMC. These verbs are *kepittää* (<*keppi* ‘stick’), *rökittää* (<*rökäle* ‘defeat’), *nokittaa* (<*nokkia* ‘peck’), *kampittaa* (<*kampata* ‘trip up’), *pyörittää* (<*pyöriä* ‘spin’) and *höykyttää* (‘hammer’). As these competition verbs show, they also comprise denominal causatives (*kepittää* and *rökittää*) and causatives with an undefinable root word relation (*höykyttää*). The derivative relations are opaque in connection with many of these verbs (on the background of *rökittää*, *nokittaa* and *höykyttää*, see footnotes 19-21 in section 2.3.2). Note that all of the examples (4-9) are newspaper headlines.

(4) *kepittää* [stick-caus] ‘to beat s.o.’

*Rasmus-Lauri **kepitti** tuloillaan Elisa-Mattilan*

‘The Rasmus’s Lauri **beats** Elisa’s Matti (the director of the telecommunication company Elisa, G.P.) in earnings’

(<http://www.taloussanomat.fi/arkisto/2005/11/01/rasmus-lauri-kepitti-tuloillaan-elisa-mattilan/200519548/12>, 3.3.2006)

(5) *rökittää* ‘to beat, wipe the floor with s.o.’

*Ruotsalaishyökkääjä haluaa **rökittää** Leijonat*

‘Swedish forward looks to **beat** Lyons (Finland’s national hockey team)’

(<http://www.mtv3.fi/urheilu/mmlatka/uutiset.shtml/arkistot/mmlatka/2008/05/647087>, 13.11.2008 )

(6) *nokittaa* [peck-caus] ‘to beat s.o.’

*Suomi **nokitti** Ruotsin salibandymaaottelussa*

‘Finland **beats** Sweden in international floorball’

(<http://www.mtv3.fi/urheilu/arkisto.shtml/arkistot/muutlajit/2001/02/46142>, 5.3.2009)

(7) *kampittaa* ‘trip s.o. up’

*Clinton **kampitti** Obaman yllättävän selvästi*

‘Clinton **trips** Obama **up** surprisingly clearly’

(<http://www.uusisuomi.fi/ulkomaat/21517-clinton-kampitti-obaman-yllattavan-selvasti>, 13.11 2008)

(8) *pyörittää* [spin-caus] ‘make s.o. spin’

*Ruotsi pyöritti Tanskaa*

‘Sweden **puts** Denmark **in a tailspin**’

(<http://www.verkkotie.fi/uutinen.phtml?id=29895>, 24.11.2005)

(9) *höykyttää höykyttää*<sup>49</sup> ‘to hammer s.o.’

*ManU höykytti Arsenalia cupissa 4–0*

‘ManU **demolished** Arsenal in cup 4–0’

(<http://www.hs.fi/urheilu/artikkeli/ManU+h%C3%B6kytytti+Arsenal+cupissa+4%E2%80%930/1135234121201>, 13.11.2008)

In addition to the defeat construction, there is a further variation of the PMC. This is exemplified by a causative whose root verb is borrowed from English and adjusted to Finnish morphology. One such verb is *nukettaa*, derived from the English word ‘nuke’, with the meaning of ‘kill with a nuclear bomb, radiate’. Note that the semantics of *nukettaa* are basically identical to the root verb; the derivation does not turn the verb into a double-causative. Remarkably, the borrowing is adjusted to Finnish using the causative suffix *ttA*, and not for instance *tA* or simply as is (*\*nuketa*, *\*nukea*). Using the causative suffix *ttA* as a general verb suffix converter seems to be a tendency in contemporary Finnish, especially in the informal register. Consider examples (10a–10b) with *nukettaa*<sup>50</sup>; they show that it can be used in a general PMC (in (10a)) as well as in a resultative situation (10b).

(10a) *nukettaa* [Eng. nuke-cause] ‘to kill with a nuclear bomb, radiate’

*/.../ muuten saattaa pelaaminen menettää mielenkiintonsa kun isot pahat pojat huijaa ja **nukettaa** poloista.*

‘...otherwise interest in playing could disappear if the bad guys swindle and **nuke** the poor guys.’

(<http://ranssi.paivola.net/lonewolf/sanak.html>, 15.11.2005)

(10b) *Välillä Jenkit nukettaa Japania kivikauteen ja välillä ovat parhaita kavereita.*

‘One day the Yanks **nuke** Japan back into the Stone Age and the next day they’re the best of friends.’

(<http://www.mp-forumi.com.nyysit>, 15.11.2005)

<sup>49</sup>The verb *höykyttää* has no clear root but is thought to be associated with the expression  *antaa höykynköykkyä* ‘give s.o. a licking’. This verb is explained in the NS as a military slang word meaning ‘arrange an extra drill or exercise’. The translation of *höykyttää* in KS is ‘to hammer’.

<sup>50</sup>According to The Urban Dictionary (*Urbaanisanakirja*), a free online slang dictionary based on users’ own contributions and evaluations, *nukettaa* means ‘to destroy’ (also figuratively) or refers to a programme that cuts a user’s Internet connection.

The conceptual analysis of (10a-10b) is given in (11a-11b) respectively. These conceptual structures lack the lower act-tier – the malefactive argument is a passive participant i.e. it assigns the role malefactive without the additional action tier role actor. However, the role malefactive associates this structure with the PMC. Note that in (11a) the causation is social, but the causation of (11b) is physical if referring to the actual use of a nuclear bomb; as the passive malefactive does not present any resistance, the semantic field of the causation is not competition. Structure (11b) additionally differs from (11a) in that there is a goal argument, STONE AGE, expressing the result. Thus, this verb occurs in the strong-weak PMC alternation. Note that the outcome in the nuking situation is devastation of the malefactive; in (11b), the implicit DESTRUCTION argument is fused with THE STONE AGE.

(11a) *Nukettaa* and strong PMC

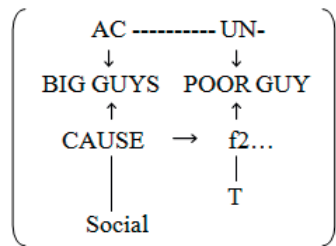

(11b) *Nukettaa* and destruction PMC

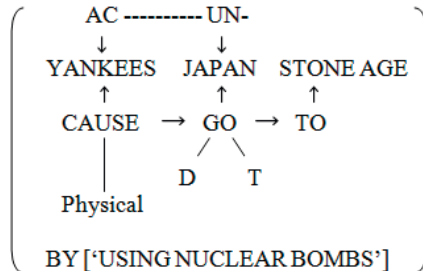

The consequence of the lack of activity of the second +human argument is that the lower action tier disappears and there is only one action tier chain; the sufficient requirement for the power misuse reading is the malefactive theme. It is remarkable that in structure (11b), the result is total devastation of the theme argument, a step further on from contest victory. This can be argued to extend the PMC to a further subconstruction. The subconstruction of the PMC with the destruction reading is analysed in (12):

## (12) Destruction PMC

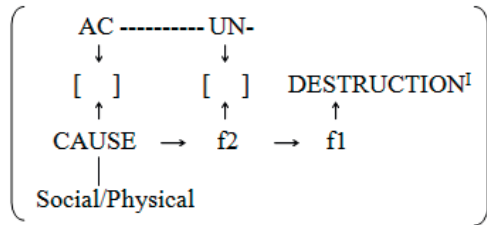
5.2.4.2 *Kyykyttää* ‘make s.o. squat’ and the semantic network

This section will concentrate on the special case of the verb *kyykyttää* ‘make s.o. squat’. My aim is to analyse the different aspects that cooperate and possibly interact in the forming of the verb’s meaning. *Kyykyttää*, according to *Kielitoimiston sanakirja* (The New Dictionary of Modern Finnish), means ‘to snooker, suppress’ and is stylistically categorised as a figurative expression used in everyday language. As discussed in section 5.2.4.1, the literary meaning of *kyykyttää* is motion from a neutral (upright) body position to the spatial configuration or being in that configuration. Does this ‘double entendre’ have an impact on the metaphorical reading of this verb? Examples (1a) and (1b) show that this verb can denote an event with or without change. In expression (1a) *kyykyttää* indicates an unbound situation without any endpoint, with the meaning ‘keeping the poor in a suppressed situation’. This situation is metaphorically comparable to the uncomfortable body position. Example (1b) describes a competitive situation where the defeat of the theme referent is the result of the process.

(1a) *kyykyttää* [squat-caus] and PMC

*Kaiken piti jatkua hyvänä ja parempana ikuisesti, mutta hyvinvointivaltiota tulikin 1990-luvulla vähemmän antelias. Se moralisoi ja kyykytti köyhiä. Se vaati työkuria, itsekuria ja säästämistä. Se korosti jokaisen omaa vastuuta.*

‘Everything was supposed to go on getting better forever, but the welfare state became less generous in the 1990s. It moralized and **bossed** the poor **around** (= made the poor squat). It demanded work discipline, self-discipline and frugality. It emphasized everybody’s individual responsibility.’

(<http://www.stakes.fi/dialogi/01/dia20013/30114b.htm>, 22.3.2006)

(1b) *kyykyttää* and defeat PMC

*Suomi kyykytti Serbian maailmantähdet*

‘Finland **beats** Serbian world stars’

(<http://yle.fi/urheilu/lajit/koripallo/kotimaa/2008/08/html>, 22.3.2006)

The verb *kyykyttää* is, for obvious reasons, frequently used when talking about sport events or political/social issues in my data. In sports situations, the competition and power struggle setting is quite clear. Also, the political and social contexts often reflect the hierarchical or polar structures on which human society is based. Compared to the verb *juoksuttaa* ‘make s.o. run’, the meaning of *kyykyttää* seems to have been metaphorized and specialised for power use. I did not find many examples of the derivative *kyykyttää* that are neutral in respect to the dominance relation, either in Internet conversations or in the text corpora. Bossy causatives in general are polysemous, applying the PMC in certain circumstances (compare with the submeanings of *juoksuttaa* discussed in 5.2.1). The derivative *kyykyttää* seems to be a relatively new derivative; I have not found this verb in dictionaries other than the relatively recent electronic dictionary *Kielitoimiston sanakirja* (2004) and the informal slang dictionary *Urbaanisanakirja*<sup>51</sup> ‘The Urban dictionary’ based on users’ own definitions of innovative or slang words and expressions. The possible dialectal origin of *kyykyttää* is not found in the dictionary of Finnish dialects *Suomen murteiden sanakirja* for the reason that the dictionary has not yet been completed.

In the search for the use of the verb *kyykyttää*, I have found that it is frequently used in online discussion settings such as Google groups. As mentioned in section 2.3.1, there were 336 hits alone with the word form *kyykyttää* (representing the 3<sup>rd</sup> person singular in the present and the 1<sup>st</sup> infinitive form) in my search on 8 August 2006. In comparison, there were 1320 hits on the same form in Google Groups on 17 November 2008 and 21,400 hits on 3 November 2010, which indicates the rapidly increasing use of this CSD. Occurrences of this verb are even found in the Finnish newspaper text collection Language Bank (*Kielipankki*): a total of 40 results of all inflectional forms. A closer look at the Language Bank’s examples reveals that as many as 33 hits come from political rhetoric. Only one example (see (2)) has an ambiguous reading (spatial/PMC); the other 39 examples denote lexicalized negative social dominance (23 defeat PMCs and

<sup>51</sup>The Urban Dictionary gives two senses for *kyykyttää*: 1. Sortaa, pistää tekemään turhia asioita, kohdella mielivaltaisesti ‘oppress; get s.o. to do s.t. in vain, treat s.o. arbitrarily’. This explanation is rated by users themselves as 79% acceptable. An example illustrating this sense is *Kela kyykyttää köyhiä* ‘The Social Insurance Institution makes the poor squat’. 2. jonkin laitteen hajoamista ‘breaking down of a device’, rated 25%.

(<http://www.urbaanisanakirja.com/index.php?action=get&wordid=438&word=kyykyttää&page=65>, 2.11.2010)

16 PMCs). This leads to the observation that *kyykyttää* has an especially strong power abuse implication compared to other bossy causatives.

(2) *Kauppa-auton uumenissa lapset on kyykytetty hyllyn viereen limsakorien jatkeeksi odottamaan aikuisten ostosreissun päättymistä.*

(Kielipankki: hs1995yo)

‘Inside the travelling shop, the kids are **made to squat** next to the soft drink crates while they wait for the adults’ shopping spree to come to an end.’

Behind the spreading of *kyykyttää* in the Language Bank data, a special influential aspect is notable: it is possible to detect the development of the metaphorical implication as it becomes more common through political rhetoric. More precisely, an influential politician’s choice of words has introduced this word as a political term. A closer look at the political examples of *kyykyttää* in the Language Bank shows that six refer to a speech given by Paavo Lipponen, the prime minister of Finland from 1995-2003. This cannot be stated as the first use of *kyykyttää*, but rather as the stylistic legalizer of this verb in ‘serious’ newspaper article texts<sup>52</sup>. This colourful utterance of Lipponen seems to have launched an increasing use of *kyykyttää* in more formal genres. Pragmatically, the *kyykyttää* expression implies a strong opinion, serving the purpose of drawing attention and provoking a reaction. A reference to Lipponen’s speech in *Demari* (the newspaper of the Social Democratic Party in Finland) is presented in (3):

(3) “*Keskustan linjan hän kiteytti niin, että puolue kyykyttäisi työreformillaan palkansaaajia vahvistamalla työnantajan neuvotteluasetelmia ja heikentämällä ansiosidonnaista sosiaaliturvaa.*”

(Kielipankki: demari1999)

‘He (Lipponen) said that the Centre Party **would boss salary earners around** with their labour reform by approving the negotiation position of employers and eating away at earnings-related social security.’

In the PMC interpretation, the theme referent, linked to the SAR, plays a crucial role, implying a hierarchical relationship between the SAD and the SAR and launching the PMC interpretation. The theme referent is not

<sup>52</sup>There is one occurrence of *kyykyttää* in the Language Bank from 1994 in the defeat PMC meaning (Korpus: hysa1994: *Vastustajan aliarviointiinkaan ei ole syytä. Sen tietää Mimmi, Marjatta Toropainen. Kiva että naisetkin voittavat. Se on ihan hyvä kokemus miehille, naurahtaa viikkokisassa miehiä kyykyttänyt Mimmi* ‘There is no reason to underestimate the adversary. Mimmi, Marjatta Toropainen, knows that. It’s nice that women can also win. This is a good experience for men, says Mimmi, who has **made** men **squat** in the week-long competition, with a smile.’), one example from 1995, four examples from 1997, two from 1998, 29 from 1999 and three from 2000.

lexically incorporated in the root verb (as for example in closely related instrumentative causatives (see Jääskeläinen 2004)). To give an idea of malefactive SAR referents, I have collated the SAR referents from the Language Bank examples with *kyykyttää* discussing politics in the following table:

Table 2. Referents of malefactives in Language Bank *kyykyttää* examples discussing politics

<i>köyhät</i>	‘the poor’	8x
<i>palkansaajat</i>	‘salary earners’	6x
<i>AY-liike</i>	‘trade union movement’	3x
<i>vähäosaiset</i>	‘the disadvantaged’	2x
<i>opiskelijat</i>	‘students’	2x
<i>ihmiset</i>	‘people’	2x
<i>alaiset</i>	‘subordinates’	1x
<i>eläkeläiset</i>	‘pensioners’	1x
<i>työttömät</i>	‘the unemployed’	1x
<i>työntekijät</i>	‘workers’	1x
<i>etätyöntekijä</i>	‘telecommuters’	1x
<i>Ne ihmiset, joiden tärkeänä palkkatyönä on auttaa todella avun tarpeessa olevia</i>	‘people whose important paid work is to help people in real need’	1x
<i>eläkeläiset, työttömät, asuntovelalliset ja heikoimmin palkattu väestö</i>	‘pensioners, the unemployed, those in debt with home loans and the lowest paid people’	1x

The nature of the theme argument leads us to another aspect influencing the meaning of *kyykyttää*. In this case, a source of influence is a close-related idiomatic expression that has obviously inspired innovative language use. As we can see in Table 2, the most frequent theme referent is *köyhät* ‘the poor’. Other malefactives are the ‘weaker’ parts of the contrasted participants (employed vs. unemployed, employers vs. salary earners etc.). In this respect, the verb is associated with the idiom *köyhät kyykkyyyn*, lit. ‘the poor into a squat’. *Köyhät kyykkyyyn* is a kind of ‘slogan idiom’<sup>53</sup>. It incorporates two lexical components: ‘the poor’ and ‘squat’. A morfosyntactic analysis of the structure of the idiom is given in (4):

<sup>53</sup> A similar slogan idiom is *rautaa rajalle* ‘iron to the border’. Like *köyhät kyykkyyyn*, it is a verbless phrase that indicates a directional event and functions as a proclamation.



## (4) KÖYHÄT KYKKYYN = ‘the poor into a squat’

<b>2</b>		<b>1</b>
köyhä+pl+nom		kykky+sg+ill
NP <sub>subj/obj</sub> (köyhät)	+	NP <sub>advl</sub> (kykkyyn)
‘the poor’		‘squat’

The syntactic function of NP *köyhät* ‘the poor’ is marked optionally as the subject or object in (4); this is based on my observations from actual language use. The idiom *köyhät kykkyyn* occurs in transitive and intransitive frames; the second NP *kykky* ‘squat’ functions as an adverbial. I illustrate the syntactic variation of *köyhät* using two examples of the *köyhät kykkyyn* idiom in a transitive and two in an intransitive frame. In (5a) and (5b) the verbs combined with the idiom are *pistää* ‘to put’ and *vaatia* ‘to demand’. Both (6a) and (6b) contain the predicate *mennä* ‘to go’.

(5a) /.../ *sitä me Vistin kanssa emme hyväksy että tehdään se matalapalkka kerho ja pistetään köyhät kykkyyn, emmehän?*  
(sfnet.keskustelu.politiikka: *Porvari-Pena* Oct 30 1998)  
‘me and Vist do not accept a creation of this low-salary-club and **putting the poor into a squat**, do we?’

(5b) *Yli miljoonan vuosipalkan miehen ei tarvitse kesälomallaan tietää mistään mitään. Lindblom onkin käyttänyt aikansa tunnetusti paremmin. Hän on vaatinut köyhiä kykkyyn laajoissa lehtihaastatteluissaan*  
(Kielipankki: *aamu1995*)  
‘A man who earns more than a million as his salary doesn’t have to know anything about anything during his summer vacation. Lindblom has made noticeably better use of his time. **He has forced** (demanded) **the poor into a squat** in his long magazine interviews.’

(6a) *Jos joku kuvitteli, että minä menen kykkyyn heti kun joku valvottava viheltää pilliin, niin erehtyi. Ovatko valvottavat niitä, jotka antavat valvovalle viranomaiselle epäluottamuslauseen, Pukkila kysyy.*  
(Kielipankki: *aamu1995*)  
‘If somebody imagined **I would go into a squat** as soon as the police blew their whistles, they were wrong. Do the police launch votes of no confidence in themselves, Pukkila asks.’

(6b) *Ruotsin EU-kansanäänestyksessä viime marraskuussa vain joka toinen sosiaalidemokraatti kannatti Carlssonin EU-politiikkaa. Kansanäänestyksen jälkeen hallitus meni kykkyyn ja unohti Euroopan.*  
(Kielipankki: *aamu1995*)

‘In the EU referendum in Sweden last November only every other voter supported Carlsson’s EU policies. After the referendum, **the government went into a squat** and forgot all about Europe.’

I give the formalization of the idiom *köyhät kyykkyy* in both transitive and intransitive frames in (7) and (8). As we can see, there is a slot for a verb in both frames. The transitive frame also has a slot for a subject argument. The NP *köyhät* (‘the poor’) is assigned as the object in the transitive frame and as the subject in the intransitive frame. The constant element is the adverbial *kyykkyy* (‘into a squat’).

(7) Transitive frame of *köyhät kyykkyy*

NP<sub>subj</sub> ( ) + V ( ) + NP<sub>obj</sub> (köyhät) + NP<sub>advl</sub> (kyykkyy)

(8) Intransitive frame of *köyhät kyykkyy*

NP<sub>subj</sub> (köyhät) + V ( ) + NP<sub>advl</sub> (kyykkyy)

Comparison of the idiom *köyhät kyykkyy* with the causative verb construction *kyykyttää köyhiä* ‘make the poor squat’ shows that it is associated with the transitive frame of the idiom; the distinction that the verb place is filled and the adverbial constituent is lacking:

(9) *kyykyttää köyhiä* [squat-caus poor-pl-part] ‘make the poor squat’

NP<sub>subj</sub> ( ) + V (kyykyttää) + NP<sub>obj</sub> (köyhät)

The idiom *köyhät kyykkyy* thus comprises two elements: a group of people (the poor) and the abstract notion of abasement. This is reflected in the *kyykyttää* examples discussed above. Recall Table 2 of malefactive (these may be seen as substitutes for the component *köyhät*): apart from one referent of malefactive, all of them are in the plural form, indicating a group of people. Also, the only malefactive in the singular does not refer to any specific person, but is actually used in a general sense (all telecommuters). Consider example (10):

(10) *Vallan harvinaista ei ole sekään, että keskijohto pönkittää asemaansa kyykyttämällä alaisia. Etätyöntekijää on vaikeata kyykyttää, ja silloin esimies tuntee oman asemansa uhatuksi.* (Kielipankki: kesu 1999)

‘It is not unheard of for central management to shore up its position **by snookering** subordinates. It is difficult to snooker telecommuters; the boss then feels that his pitch is threatened.’

There is an underlying implication of social activity that causes the abasement of this group, who are understood to be disadvantaged. The idiom *köyhät kyykkyy* implies the speaker’s strongly critical attitude towards a

situation where people who already find themselves in difficult conditions are forced into an even more inconvenient position (the speaker's perspective on the power abuse situation is discussed in more detail in section 5.2.6). The metaphorical reference to the position of the human body can be argued to be seen as an embodied experience of a physical force dragooning the body into an inconvenient position (for body language and its abstract use (embodiment) and the significance of the human body for cognition, see for instance Gibbs 2006). The significance of *kyykky*, a special body posture, implies that a person is beneath the (unmarked) upright position, diverging from the distinctive human position. The illative case indicates the motion into this position. The denotation of the whole expression is thus 'to snooker or put people in need in a fraught position', and figuratively also 'to cause the diminishing of the space of the poor'. Metaphorically, being in the lower position of a squat means abasement.

When a situation expresses a process, it is generally seen as a feature of a verb. However, the illative case of the word *kyykky* is a sign of change, which allows us to interpret the situation as an event. As Kainlauri (2005) points out, the illative case includes both motion and causation components. Also, the conceptual structure of *köyhät kyykkyy* reflects both components; an essential part of the meaning of this idiom is transition/change. The LCS of *köyhät kyykkyy* is given in (11). Despite the fact that the idiom is verbless, its LCS includes the event-function GO whose second argument is a path. Since *kyykky* implies motion into a position and then maintaining it, the function GO is followed by the path-function TO (whose argument is the component referring to the location). In structure (11), there is an optional causer (selected by the optional CAUSE-function, in angled brackets). The dominance between the participants is analyzed in the action tier. The optional causer is thus the possible actor argument, and the theme argument *köyhät* (THE POOR) is the malefactive. The semantic field of the causation is social, while in the core zones it is circumstantial.

- (11) Conceptual structure of *köyhät kyykkyy* [poor-pl-nom squat-ill]  
 'the poor into a squat'

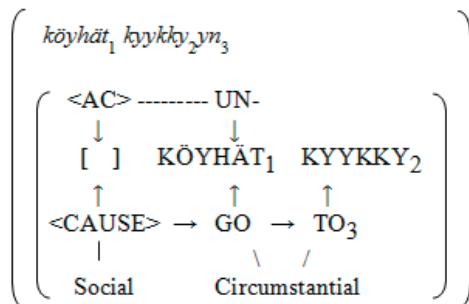

How does the LCS of *kyykyttää köyhiä* differ from the idiom *köyhät kyykkyy*? The LCS of *kyykyttää köyhiä* is given in (12). Here the CAUSE function is obligatory, with an open argument place. As in (11), the theme argument is KÖYHÄT ('the poor') and the location the theme is transferred to is KYYKKY ('squat'). Thus, the LCSs of these two phrases are almost identical. The difference lays in the linking system between syntactic and conceptual structures: in (11), *kyyky* corresponds to the adverbial NP argument, while in (12) it is an implicit argument of the verb; in the LCS, *kyyky* is in both cases the goal argument.

(12) Conceptual structure of *kyykyttää köyhiä* [squat-caus poor-pl-part]  
'make the poor squat'

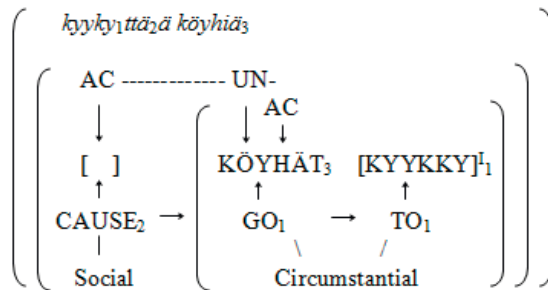

The actual use of *kyykyttää* in Internet discussion groups reveals an entire network of submeanings. What in context tells us that it is a question of PMC and not the compositional meaning of the causative verb? I would argue that the theme argument or the substitute of *köyhät* 'the poor' is of crucial importance here. Based on the use of *kyykyttää* in my material, its submeanings can roughly be classified into six categories (of course, the subject matters are far more broad; for instance, the use of *kyykyttää* in competitive situations can be extended to competitive areas other than sports, like economics):

1. society and politics (mistreat a suppressed group of people)
  2. sports (defeat, overpower an opponent)
  3. army (bullying)
  4. technology (to cause a breakdown or functional trouble in a system)
  5. spatial movement (compositional meaning: 'make s.o. go into a squat')
  6. spatial configuration (sit on a motorcycle in a squat position)
- } PMC

The first three categories and concurrently also the subject matter of the verb *kyykyttää* (politics, sport and the army) correspond with the PMC. I give

one example of the verb in each category in (13a-f). Example (13a) represents the use of *kyykyttää* in political discourse, (13b) in sport (competition) and (13c) in the context of national defence. Example (13d) is from a discussion about information technology (atk.laitteet); (13e) comes from a spatial motion context; and (13f) is an example of the specialised meaning of *kyykyttää*, taken from a discussion held among a group of motorcycle enthusiasts (harrastus.mp). (The verb is used in regard to riding a special type of motorcycle that makes the driver assume a particular posture.) Note that the motorcycle driving variant of *kyykyttää* denotes the spatial configuration without the causation element.

(13a) *Se se vaan on sillä lailla, että markkinatalouden lainalaisuudet määräivät kaikesta myös suomessa vaikka uustaantumukselliset yrittäisivät asian kieltäinkin (muistakaapa vaikka kelluva markka joskus aikoinaan, kun markkinavoimat menen tullen **kyykyttivät** Suomen hallitusta).*

(sfnet.keskustelu.politiikka: Uustaantumukselliset ??? Mar 9 2005)

‘That’s just the way it is: market economy laws rule all management of finances in Finland, too, although neoreactionists try to deny it (remember the floating mark at one time, when market forces **had** the Finnish government **squat** just like that?).’

(13b) *Tapanilan Erä **kyykytti** Espoon Oilersia keskiviikon salibandykierroksella maalein 11-4.*

‘Tapanilan Erä **beat** Espoon Oilers 11-4 in floorball on Wednesday.’

([http://plaza.fi/stadion/palloilu/salibandy/uutiset/era-kyykytti-oilersia-salibandy liigassa, 30.8.2005](http://plaza.fi/stadion/palloilu/salibandy/uutiset/era-kyykytti-oilersia-salibandy-liigassa,30.8.2005))

(13c) *Sitä paitsi: Eikös ne KUITENKIN ole ne VARUSmiesjohtajat, jotka useimmiten syyllistyvät simputukseen, eivät skapparit? Yksi syy tuohon voisi olla siinä että kun varusmiesjohtaja **kyykyttää** alokkaita/sotamiehiä se on simputusta mutta kun skappari **kyykyttää** se "urheilu koulutusta".*

(sfnet.keskustelu.maanpuolustus: Miksi nuori valitsee armeijauran. Jun 13 2003)

‘Besides: isn't it the CONSCRIPT leaders who most often do the bullying, not the regulars? One reason for this might be that when a conscript leader has recruits squat, it's bullying, but when a regular has them squat, it's "training".’

(13d) *Nettimato **kyykyttää** hakukoneita*

‘Net worm **brings down** search engines’

([www.bittivuoto.net/uutiset.php4?kat=7&id=2658](http://www.bittivuoto.net/uutiset.php4?kat=7&id=2658), 30.8.2005)

- (13e) *Aloitimme harjoittelun lokakuussa. Aluksi me totutelimme veteen niin, että **kyykytin** Meriä portaita. Sen jälkeen hän kellui pelastusrenkaan kanssa ja nyt olemme siirtyneen turvaliiveihin ja opettelemme rintauintiliikkeitä, Paula Vepsä kertoo.*  
 ‘We started training in October. At first we accustomed ourselves to the water, so I **had** Meri **squat** on the stairs. After that she floated using a life buoy and now we’ve gone over to the life vest and learning breaststroke, says Paula Vepsä.’  
 (<http://www.esaimaa.fi/arkisto/vanhat/2006/01/28/teemat/sunnuntai/juttu3/sivu.html>, 22.3.2006)

- (13f) *Hyvä ja ongelmaton joka paikan peruspyörä, halpa pitää ja hoitaa mutta moderneimpiin nähden hieman painavampi (=tukevampi) ja rauhallisempi. CB sopii sille joka ei jaksa enää **kyykyttää**, jolle seuraaviin valoihin ulvottaminen tuntuu lapselliselta ja jolle tehdascustomien ajoasennon rasittavuus reissussa on käynyt selville.*  
 (sfnet.harrastus.mp: Käyttökokemuksia? Jan 30 2002)  
 ‘A good and trouble-free all-terrain basic cycle, cheap to use and take care of, but a bit sturdier and more stable compared to more modern cycles. CB suits those who don’t have the patience **to squat**, who feel childish about screaming till the next set of lights and who have discovered the strenuousness of the factory-setting driving position for themselves.’

Naturally, the use of the verb *kyykyttää* is not restricted to these topics; another possible topic is everyday human social relationships:

- (14) *Itse tykkään **kyykyttää**, pompottaa ja dominoida miehiä ihan jokapäiväisessä elämässä. Ne on sellaisia pikkujuttuja joista nautin, vähän niin kuin siitä, jos koira tuo minulle heittämäni kepin tai tohvelit.*  
 ‘I like **bossing** men **around**, walking all over them and dominating them in everyday life. Small potatoes, but I enjoy them – a bit like a dog bringing me a stick or my slippers.’  
 (<http://avionrikkoja.blogspot.com/2005/01/miksi-naiset-sanovat-yht-ja-tekevt.html>, 30.8.2005)

Figure 1 below is a visual representation of the network of metaphorical and constructional elements and connections between the spatial configuration noun *kyykky*, the verb *kyykyttää* with its submeanings, the PMC and the *köyhät kyykkyy* idiom. Figure 1 thus reflects relational senses and interpretative and metaphorical associations. I have marked the connections between the PMC, *kyykyttää*, *köyhät kyykkyy* and the central subject matters ‘politics and society’ using a bold line so as to mark the strong links between these phenomena. The dashed lines indicate weaker links.

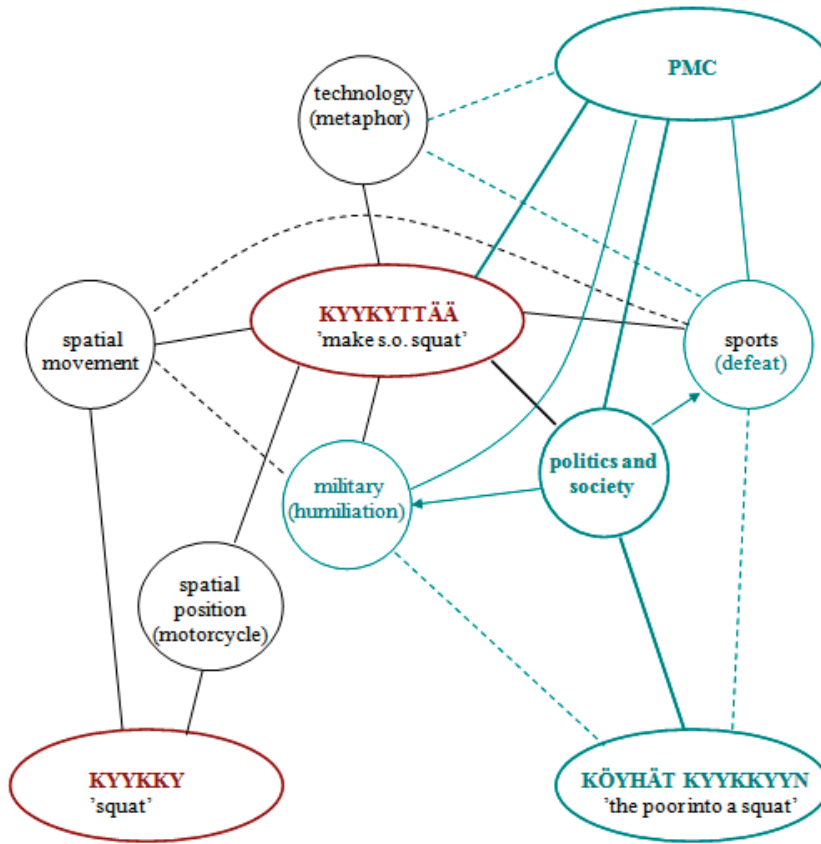

Figure 1. *Kyykyttää* and *köyhät kyykkyy*: the network of constructions and submeanings

Interestingly, *kyykyttää* can even be derived further and used with quite a similar meaning. By adding the frequentative morpheme *-ele* to this CSD, the result is the derivative *kyykytellä*. In addition to the recurrence or continuity of an activity, this derivative suffix can add nuances like irregularity, randomness or lower intensity (ISK §354). This verb is not used in my data in a competitive situation like the *kyykyttää* variant, but as a humiliation verb:

(15a) *kyykytellä* [squat-freq-caus] ‘make s.o. squat’

*Voihan se siivooja huudella, mutta ei voine edellyttää kenenkään tottelevan... :) Eihän skapparikaan (tai esimiesasemassa oleva yleensäkkään) saa kyykytellä alaisiaan miten lystää, ainakaan ilman jälkiseuraamuksia.*

(sfnet.keskustelu.maanpuolustus: Reserviin luutnanttina. Oct 23 2002)

‘The cleaner may yell, but cannot really expect anyone to obey... :) Not even a regular (or anyone in a superior position) can **boss** subordinates **around** without consequences.’

- (15b) *PS. Muutenkin, mikä ihmeen hinku ihmisillä on ensi kädessä suunnaton tarve **kyykytellä** toisia nyysseissä?*  
 (sfnet.harrastus.musiikki: Napster on ihan syvalta! Aug 17 2000)  
 ‘P.S. Anyway, what drives people to **boss** others **around** more than anything in newsgroups?’

In section 5.2.1, I studied the polysemy of the verb *juoksuttaa* ‘make s.o. run’ by analysing the first 100 results from Google<sup>54</sup>. As a comparison, I collected a similar sample of *kyykyttää* ‘make s.o. squat’. Interestingly, 84 of the 100 results were PMC uses; only 16 were neutral regarding power relationships. The distribution of the submeanings is presented in Table 3:

Table 3. 100 results of *kyykyttää* ‘make s.o. squat’ from Google

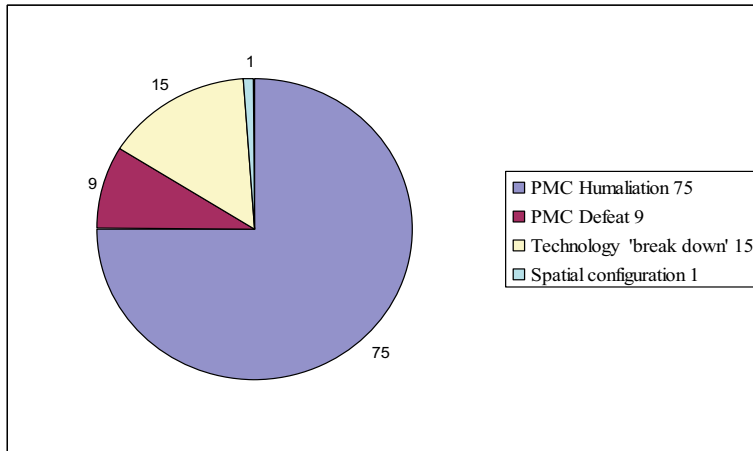

The PMC examples primarily encode the pure humiliation variant (PMC); nine results are competition situations (the defeat PMC), mainly from contexts dealing with sports or the economy. The humiliation results include seven cases of the Social Insurance Institution KELA as the SAD referent. Three of the SAR referents were *köyhät* (‘the poor’); other SARs included *vähävaraiset* (‘the disadvantaged’), *köyhät viljeilijät* (‘poor farmers’), *opiskelijat* (‘students’), *naiset* (‘women’), *ihmiset* (‘people’), *asiakas* (‘the client’), *kansa* (‘the people’) and *lapset* (‘children’). One example was with *keskiluokka* (‘the middle class’): see example (16). Of the 16 cases of neutral power relationships, 15 were in a technology context. I present two examples

<sup>54</sup> The search was conducted on 2 April 2009; the total number of hits on the form *kyykyttää* was 26,300.



from this material. Example (16) represents a PMC variant. The only spatial denotation example (17) expresses the spatial configuration without causation in connection with driving a snowmobile at a rally (see (17); this use of *kyykyttää* is comparable to the motorcycle driving example in (13f)). However, example (17) involves a certain connotational ambiguity in that the driver masters the snowmobile.

(16) *Amerikka kyykyttää nyt keskiluokkaa* (headline, GP.)

*Nälkäpalkalla-kirjan tekijä Barbara Ehrenreich ylikoulutettujen ja alityöllistettyjen ihmemaassa*

‘America now **suppressing** the middle class

The author of *Nickel and Dimed - On (Not) Getting by in America*

Barbara Ehrenreich in the wonderland of the overeducated and the underemployed’

(<http://www.hs.fi/artikkeli/Amerikka+kyykytt%C3%A4%C3%A4+nyt+keskiluokkaa/1135224110348>, 30.8.2005)

(17) *Rallikuski Juuso Pykälistö kyykyttää kisamoottorikelkkaa*

*Miten sujuu rallikusilta moottorikelkkailu MM-tason kelkalla?*

‘Rally driver Juuso Pykälistö **squats** snow mobile (headline, G.P.)

How does a rally driver handle driving a snowmobile on a WC-quality mobile?’

(<http://www.iltasanomat.fi/urheilu/uutinen.asp?id=1643720>, 30.8.2005)

### 5.2.5 Associative binding within PMC subconstructions

To round up the discussion of the PMC and verbs adjusting to the negative power relation construction, it can be concluded that this is a construction with variations. The PMC can be separated into further, related constructional patterns according to the dominance effect on the SAR: humiliation, defeat and total destruction. The humiliation pattern occurs in the aspectual alteration of the weak-strong PMC. These form the core of the PMC. Some verbs (*kyykyttää*, *kynittää*) occur in addition to the core PMC in the defeat PMC. The causatives of the defeat PMC group denote a win-lose situation, which has an analogy in the power axis but also in competitive situations. The destruction construction includes the verb *nukettaa* [nuke-caus].

In an overview of these constructions, in the development from concrete meaning to abstract, CSDs derived from motion verbs can be seen to be an explanation for the emergence of the PMC. These derivatives are metaphorically a complex of ‘controlled motion’ or more precisely ‘motion controlled by s.o. other than the mover’. CSDs derived from motion verbs can be seen as the core of PMC members; as the construction strengthens and a more general rule appears, new verbs may adapt the pattern. The extension

of the motion event to more abstract types of activities enables CSDs derived from roots other than motion verbs to adopt the pattern. In the case of motion PMC verbs, the motion component and the dominance component are balanced between a concrete motion denotation and more abstract activity. Naturally, other types of PMC verbs may be associated with their basic meaning. The continuum of causative motion verbs from the neutral dominance relation to the Power Misuse Construction can be represented as in Figure 2:

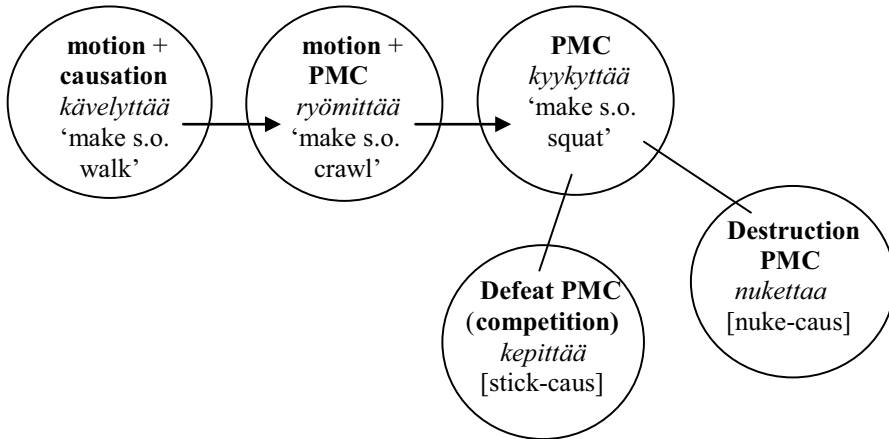

Figure 2. Continuum of causative motion verbs to PMC and its subconstructions

What links the different members of the construction family? The common features of bossy causatives are social causation and the specific power relationship between the participants. The shared features are +human arguments, social causation (in the case of defeat construction, the semantic field of causation is a subcategory of the social field, competition) and the malefactive theme argument as well as the activity of the theme argument. As long as these features are present, the PMC reading is possible. The actual formation processes behind single lexemes may vary – they can be deverbal or denominal causatives and even verbs with indeterminable derivative relations. An interesting group is the defeat PMC and the lexicalised ‘overpowering’ *ttA*-verbs (*kampittaa*, *nokittaa*, *rökittää* and *höykyttää*: recall the discussion in 5.2.4.1) which may form an analogy-based impetus for the dispersal of the PMC pattern. The possibility of verbs banding together with the verbs in a construction group is thus based on analogy-based relationships, not simply on combining the bases with the suffixes; verbs participating in constructions form an associative network.

Bossy causatives differ in their ability to occur in the centre of the motion causative continuum. Consider the examples with the CSD *juoksuttaa*, where

(1a) denotes motion and causation without the power abuse component and (1b-c), in addition to the motion, also encode the negative dominance. These examples are from my material but represent a simplified version of them i.e. the argument structure of the utterances is retained.

(1a) *Valmentaja juoksuuttaa urheilijaa*  
'The coach makes the athlete run.'

(1b) *Asiakas juoksuuttaa lentoemäntää*  
'The customer keeps the stewardess running around.'

(1c) *Kela juoksuuttaa asiakkaita*  
'The Social Insurance Institution runs customers around.'

The competition verbs *rökittää* and *nokittaa* mainly occur in the defeat construction. Other competition verbs, *kampittaa*, *kynittää* and *kepittää*, also apply the PMC (consider examples (2a-b)). These verbs do not include the motion component.

(2a) *kampittaa* [trip-caus] 'trip s.o. up'

*Sisäministerön tulkinta **kampittaa** yhdistystoimintaa verkossa*  
(headline)

*Electronic Frontier Finland ry:n (EFFI) mielestä sisäministeriön  
valitsema linja rahankeräyslain tulkinnassa hankaloittaa laillista  
yhdistystoimintaa verkossa.*

'Ministry of the Interior interpretation **suppresses** online association activity

According to the Electronic Frontier Finland association, the line the Ministry of the Interior is taking in the interpretation of fund-raising law hampers legal association activity on the Internet.'

(<http://www.ffi.org/julkaisut/tiedotteet/lehdistotiedote-2006-02-02.html>, 10.11.2008)

(2b) *kynittää* [pluck-caus] 'exploit s.o.; beat'

*Eräänlainen pienenisyhteiskunta, jossa ei tarvi huijata toisia eikä  
**kynittää** kun kaikki tietävät saavansa saman verran.*

'A kind of mini-society where there is no need to cheat others or **exploit** (take advantage of) them when everyone knows they get an equal share.'

(<http://www.fi-reggae.com/read.php?f=10&i=14317&t=14070>, 24.11.2005)

*Kyykyttää* is a versatile verb which is able to occur almost anywhere in the continuum. However, it seems to specialize in the power abuse reading;

therefore, its spatial reading needs more contextual support than the PMC interpretation. I will return to the effect of context in section 5.2.6 below. Example (3e) suggests that this verb may even be used in the destruction construction. Consider the examples with *kyykyttää* below:

(3a) Motion + causation

*Aloitimme harjoittelun lokakuussa. Aluksi me totuttelimme veteen niin, että **kyykytin** Meriä portailla. Sen jälkeen hän kellui pelastusrenkaan kanssa ja nyt olemme siirtyneen turvaliiveihin ja opettelemme rintauintiliikkeitä, Paula Vepsä kertoo.*

I **had** Meri **squat** on the stairs. After that she floated using a life buoy and now we've gone over to the life vest and learning breaststroke, says Paula Vepsä.'

(<http://www.esaimaa.fi/arkisto/vanhat/2006/01/28/teemat/sunnuntai/juttu3/sivu.html>, 22.3.2006)

(3b) Motion + PMC

*Kauppa-auton uumenissa lapset on **kyykytetty** hyllyn viereen limsakorien jatkeeksi odottamaan aikuisten ostosreissun päättymistä.*

Kielipankki: hs1995yo

'Inside the travelling shop, the kids are **made to squat** next to the soft drink crates while they wait for the adults' shopping spree to come to an end.'

(3c) PMC

*Kohinaa aiheutti pari vuotta takaperin se tutkimuksen huomio, että järjestelmän tarkoitus ei ole auttaa työtöntä, vaan **kyykyttää** sosiaaliluukulle saapuvaa, jotta tämä olisi mahdollisimman epämiellyttävä kokemus ja saapuja jättäisi ensikerralla tulematta.*  
(sfnet.keskustelu.politiikka: Paljonko työtön "tienaa"? Oct 8 2003)

(3d) Competition

*Lukko **kyykytti** Jokereita 6–0*

([http://www.ls24.fi/jaakiekko/lukko\\_kyykytti\\_\\_jokereita\\_60\\_1767691.html](http://www.ls24.fi/jaakiekko/lukko_kyykytti__jokereita_60_1767691.html), 21.10.2008)

(3e) Destruction

*UMTS **kyykyttää** Cubion verkon nopeudessa 6-0*

'Speed sees UMTS **beat** Cubio 6-0'

(<http://www.matkapuhelininfo.com/forum/viewtopic.php?start=40&t=33930>, 21.10.2008)

Common to PMC verbs is that they seldom reflect the attitude of the propositional participants to the negative dominance; it is the referrer/speaker does not agree with the ‘ruling over s.o. with a heavy hand’ situation. I discuss this phenomenon in more detail in section 5.2.6. A look of reproach and disapproval is there in the case of PMC (humiliation), but not in the defeat PMC. The competition expressions are not as mortifying as the humiliation PMC, because the competition settings are usually less ambiguous and the conditions are the same for the opponents. The look of reproach is therefore not as strong in the defeat PMC. The defeat examples may imply a portion of humiliation, especially if the winner was not anticipated. Recall the examples with *kyykyttää*: in (1), the Finnish ice hockey team gets the better of the Swedish team before the semi-final, which bodes especially ill for a strong ice hockey country like Sweden. In (2), Finland are the underdogs while the Serbian team enjoys the status of world stars.

(1) *Suomi kyykytti puolivälierässä Ruotsin 2-1*

‘Finland **beat** Sweden 2-1 in semi-final’

(sfnet.urheilu.jaakiekko, 13.5.2005)

(2) *Suomi kyykytti Serbian maailmantähdet*

‘Finland **beat** Serbian world stars’

(<http://yle.fi/urheilu/lajit/koripallo/kotimaa/2008/08/html>, 21.10.2008)

The subconstructions of the PMC can be seen as a construction family: they are related to each other but have their own nuances. The idea of constructions forming a network based on inheritance links (a relation where one construction dominates another related construction) is emphasised in Fillmore (1999) and Goldberg (1995). Also, Björklund, Nikanne and Virtanen (2003) support the idea of a construction family, with the difference that the links are not assumed to have an inherited nature. Their analysis is based on variations of the idiom *Vetää herne nenään* (literally: ‘to pull a pea into the nose’), meaning ‘to have a fit’. The variations can be seen as separable but related constructions. Here, the invariable formal feature is [[ ] ttA], and the lexicalized power relation.

### 5.2.6 Power Misuse Construction and interpretation constructions

The discussion in previous sections shows that the central semantic features of the PMC are humiliation of the SAR and the negative dominance relationship – the troubling effect on the malefactive SAR is typically an effect of the activity of the SAD. This implies that there is an experiencer or observer of the tribulations. The central question is: whose estimation is it

that the SAR undergoes a mortifying situation when the PMC is used? Who is actually the disapprover of the circumstances of the dominance relationship? I suggest that the PMC reading is closely related to the communicative function of the PMC expression. The use of the PMC reveals a noticeable interactional tendency common to power abuse expression: there is a sense of reproach, but not necessarily from the point of view of the SAR, who is not automatically conscious of the humiliation or futility of its activity. There appears to be a *third* participant with disapproving views on the situation when the PMC is used. The disapproval attitude explains how the Power Misuse Construction has become part of the lexicon. In this case the lexicalization must have taken place via dialogue, and more precisely via a certain perspective on a specific situation. Consider the following PMC examples from language use in Internet conversations using bossy causatives:

(1) *kyykyttää* [squat-caus] ‘make s.o. squat’

*Katsellesani tänään kuinka eräs parasta ennen -päiväyksen ohittanut, vahva ja upea nainen **kyykytti** myyjäparkaa etsityttämällä juuri rouvalle sopivaa kosmetiikkatuotetta, tuli jälleen kerran mieleeni se kuinka kosmetiikkassakin myydään pikemminkin jotain muuta kuin itse tuotetta.*

‘As I watched this strong, gorgeous woman, already past her best before date, **bossing** the poor sales person **around** by having her find exactly the right cosmetics for the Lady, it crossed my mind again that even within cosmetics they are selling something more than just the product itself.’

(<http://www.geocities.com/heteroseksuaalisuus/August-2003.html>, 22.3.2006)

(2) *juoksuttaa* [run-caus] ‘make s.o. run’

*On eduskunnan oma häpeä, että se aikanaan on luovuttanut valtaa eturyhmille ja järjestöille, jotka vielä tänään panivat jälleen kerran koko parlamentaarisen järjestelmän polvilleen uhkaamalla suistaa Suomen turmioon poliittisen lakon avulla. On kansanedustajien oma häpeä, jos puoluetoimistot **juoksuttavat** edustajia.*

‘It is a black mark on the parliament itself that it has ceded power to the very interest groups and associations who have brought the entire parliamentary system to its knees by threatening to derail Finland through political strikes. It is a black mark on the representatives themselves if they let the party offices **run** them **around**.’

([http://217.71.145.20/TRIPviewer/show.asp?otsikko='73.1994+2\)+HE+135/1994+LK+Ed.+Ukkola'+numero=5525&base=ptk&f=SIS\\_FRM&kieli=su&ylapalkki=akxtripview&palvelin=www.eduskunta.fi&](http://217.71.145.20/TRIPviewer/show.asp?otsikko='73.1994+2)+HE+135/1994+LK+Ed.+Ukkola'+numero=5525&base=ptk&f=SIS_FRM&kieli=su&ylapalkki=akxtripview&palvelin=www.eduskunta.fi&), 30.8.2005)

(3) *tanssittaa* [dance-caus] ‘make s.o. dance’

*Diiva tanssittaa pillinsä mukaan niin nykyistä kuin entisiä miehiään, tytärtään ja uskollista kotiapuaan, ja 60-vuotispäiviensä kynnyksellä sankaritar on, jos mahdollista, tavanomaistakin hankalampi.*

‘The diva **has** her current and ex-husbands, her daughter and her loyal servant **dance** to her tune, and is, if possible, even more of a burden than usual on the eve of her 60<sup>th</sup> birthday.’

([www.tampereenkomediateatteri.fi/KomediaSanomat0805.pdf](http://www.tampereenkomediateatteri.fi/KomediaSanomat0805.pdf), 23.4.2007)

An observer’s perspective is present as a common feature in examples (1-3). Common to these examples is that the speaker, who is a participant outside of the power misuse situation being portrayed, perceives the dominance between the referents of the SAD and the SAR as being negative. In (1), the speaker has seen a difficult customer demanding service in a cosmetics store and reports on the unreasonable and fruitless activity that the salesperson (SAR) has to perform, at the same time expressing disapproval towards the behaviour of the customer (SAD). Also, example (2) is expressed via the speaker’s opinion that the SAD is controlling the situation in a questionable manner. In the power balancing example of (3), the predicate *tanssittaa* ‘make s.o. dance’ forms part of the phrase *tanssia jonkun pillin mukaan* ‘dance to s.o.’s tune’. The sentence describes, in a humorous manner, the exercising of power of the ‘diva’ in her relationships.

A slightly different example with the verb *juoksuttaa* ‘make s.o. run’ is (4) – the goal of the SAD (the therapist) is not necessarily to cause the SAR (the patient) inconvenience, but rather to let the SAR carry on with his futile activity. Here the same verb has a permissive meaning instead of a causative one: the SAD is aware of the uselessness of the SAR’s activity, but is in this case unable to prevent it while the SAR remains unaware of the fruitlessness of the activity. Furthermore, the speaker experiences the influence of the SAD on the SAR rather as a positive, and the sympathy is for the SAD. The SAD assigns, however, the role malefactive.

(4) *Terapeuttilhan ei voi mitään potilaalle antaa tai siirtää. Hän voi vain juoksuttaa potilasta oravapyörässä ja odottaa hetkeä, jolloin tämä huomaisi oman hullutuksensa.*

‘The therapist cannot give or transfer anything to the patient. He can only **have** the patient **run on a treadmill** and wait for the moment he becomes aware of his own insanity.’

([http://www.netlife.fi/users/msiivola/krit/alitajunnan\\_asiantuntijat.html](http://www.netlife.fi/users/msiivola/krit/alitajunnan_asiantuntijat.html), 30.5.2005)

The power abuse reading may also arise from the implication that the SAR is forced to perform an activity that should be the SAD's own *responsibility*. Consider the following example, a headline in a local newspaper:

(5) *Peruspalvelukeskus Oiva juoksuttaa vanhuksia*

*Peruspalvelukeskus Oiva on jättänyt vanhukset oman onnensa nojaan Eläkeliiton Päijät-Hämeen piirin mukaan. Lääkäripulan takia vanhuksia juoksutetaan kunnasta toiseen lääkäriin.*

‘Oiva medical centre **running** elderly **around**

The Oiva medical centre has left the elderly to their own devices, according to the Päijät-Häme office of the Pension Association. Because of the shortage of doctors, the elderly are **being made to run around** from one centre to the next to see a doctor.’

(<http://www.ess.fi/?article=215468>, 23.2.2009)

As the examples show, the PMC reading is sensitive to the context in which it occurs. Central to all examples with bossy causatives is the futility of the SAR's activity and the SAD's misuse of the dominant position. The reproach is not necessarily directed at one of the participants, but the situation in which the power is misused. The speaker is the observer and interpreter whose judgment of the power abuse situation is stated.

Use of the bossy causative construction indicates an instantly recognizable opinion regarding and attitude towards the proposition in the communicative situation. In the prototypical case, the speaker infers that the SAD is ignoring social values and conventions that a responsible member of society should follow. The speaker expresses a complaint to the listener about another situation where one participant (the referent of the SAD) is misusing another (the referent of the SAR). Consequently, there are two different situations here that should be considered – the **power-using situation** on the one hand and the **communicative situation** on the other. Additionally, the spatial reading that the root verb brings to the proposition influences the entire meaning. However, a power-using situation that describes the social relations between the participants in the event should be separated from the description of spatial-physical relations that, for instance, CSDs derived from motion verbs encode. These aspects form part of the **spatial situation**. An overall account of the situations included in the communicative use of the Power Misuse Construction is depicted in Figure 3.



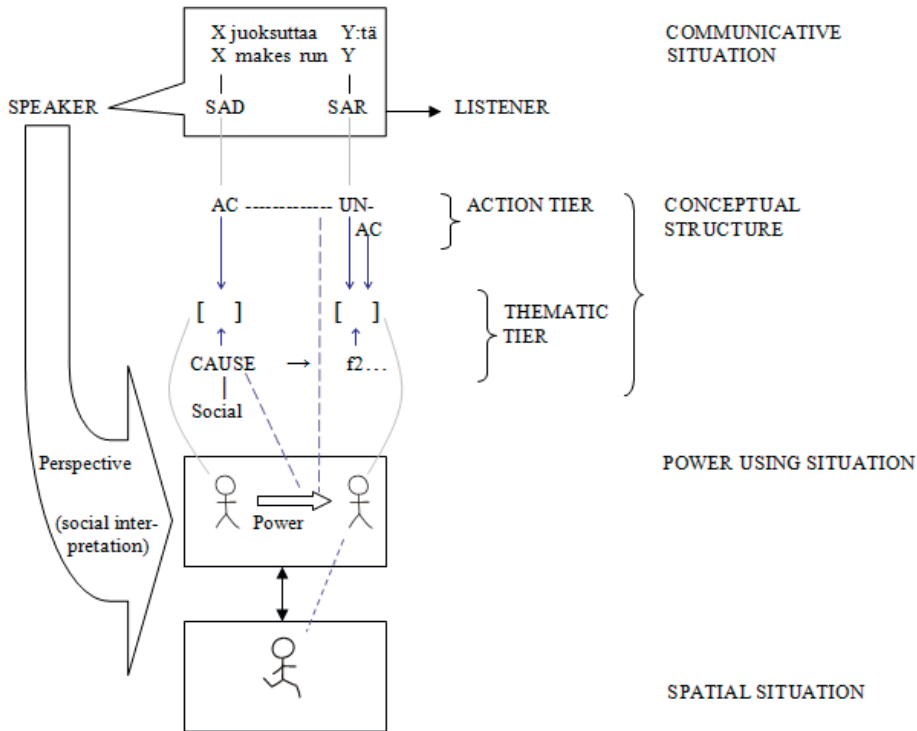

Figure 3. PMC construction and communicative situation

Figure 3 describes situations and different conceptual structure levels and illustrates how they are related to one another. The whole system demonstrates a complex integration of communicative, linguistic, social and spatial relations. The linguistic form of the message is part of the communicative situation. As we can see in Figure 3, both the communicative and power-using situation are linked to the conceptual structure, the mental representation of linguistic information. The interpretation of social relations and the character of dominance are made and drawn on the basis of the power-using situation. This is also where the 'bossy' reading or power abuse perspective arises. I have used broken lines to indicate the correspondence between the components of these domains, mapping the arguments of the conceptual structure and the participants in different situations.

The Power Misuse Construction is an example of an intertwined combination of both spatial and social features, separated into different levels in Figure 3. It shows how the 'person in society' is expressed in language. In conceptual structure, the information from the power use situation and from the spatial situation is translated into the action tier level and thematic tier level respectively. But components of the power use situation belong to the

thematic tier as well. The different aspects of social relations are divided within the conceptual structure; the action tier describes the activity and passivity of participants and the domination between them and the thematic tier describes the causation (recall the discussion on the principles of conceptual semantics in section 2.2). Hence, the force or energy described in the power use situation has two sides – the domination and the causation (these levels are connected to each other with a broken line in Figure 3). The spatial representation dealing with the physical objects in the space and the social representation expressing the people in social interaction are intertwined in a PMC expression, as examples (1-4) show. How much spatial information remains? Is it replaced by the social features? Do social and spatial relations belong to different domains in the conceptualization?

Figure 3 also accounts for the semantic field analysis. The background of an event is described by semantic fields. According to Nikanne (1990), the possible semantic fields of causation (located in zone 3) are different from the semantic fields of the thematic and location zones i.e. zone 2 and zone 1 respectively. However, dominance can happen in different cognitive backgrounds, too (or at least there can be physical and social dominance; we also saw the competitive nature of causation in the case of the defeat construction). Both the upper act-tier as well as the causation element are central components of the power use situation. This supports the assumption that the influence area of a semantic field reaches out across the zone (Nikanne 1990). At least in the case of the PMC, the nature of both causation and dominance is stipulated in the power use situation (see Figure 3).

What kind of social context characterizes the power misuse situation? The fact that someone has the possibility to dominate another person implies a social hierarchy. Jackendoff (1992a) points out that the consequences of the social dominance hierarchy are that the dominant individual has the authority to issue orders, to expect compliance, and to impose sanctions if the orders are not obeyed. Why is the activity of the SAD in the power misuse situation disapproved of by the speaker? Is it because the speaker does not accept the dominance of the SAD? In my opinion, the authority of the SAD is questionable, because it does not act in the way a responsible member of society is expected to act; cultural norms form the background of the disapproval.

We can conclude that the speaker's perspective on the PMC situation is at the same time their *interpretation* of it, based on their experience and the recognition that the SAD is misusing its power. The building blocks of the construction in question are information on social dimensions like dominance and causation and additionally an attitude to the described situation. Disapproval is particular to this construction; it does not follow directly from the lexical properties of the verb, but from the verb-context interface. I suggest that this kind of construction based on assessment and a conventionalized interpretation of the situation expressed by the proposition

be named the ‘**interpretation construction**’. The property of the interpretation construction is contextual linking as a precondition for the possibility of the occurrence of such a pattern. There may be a range of conventionalized interpretative implications from which the language user selects the most appropriate. Hence, because of the contextual impact on the PMC proposition, it is characterised as a kind of interface construction.

The power abuse meaning seems to be conventionalized in connection to bossy causative verbs derived from a motion verb even when the proposition indicates a concrete spatial movement. Consider e.g. the sentence in (6):

- (6) *Valmentaja juokсутtaa poikia tunnin*  
 trainer run-caus-pres-3sg boy-pl-part hour-acc  
 ‘The trainer makes the boys run for an hour.’

Sentence (6) implies the SAD’s (‘trainer’) authority while the SAR (‘boys’) follows the order and moves. How has a proposition that describes spatial and social relations developed into a power abuse construction? Since the SAD has control over the SAR’s activity, it creates the environment for the misuse of power. Language users interpret situations and express attitudes that they have towards certain social situations. If the context clearly indicates that the SAD is not misusing its power, the negative influence reading is not triggered. This suggests that the interpretation of social interaction between the participants in a situation can be fixed in the lexicon and constructions.

The PMC verbs analysed hereto correspond to the single-causative prototype PT2.2 (see section 3.4). Can a CSD proposition representing a double-causative prototype also assign the PMC? Consider the example with a CSD derived from an instrumental verb in (6). Similar to motion verb CSDs, the activity is performed by the SAR’s own force in the case of the verb *pesettää* ‘make s.o. Wash; however, this actor is not linked to a theme argument, but to a causer argument, since it is assigned to the second of the two CAUSE-functions in the LCS of *pesettää*. Consequently, the SAR has a theme argument on which to cause an effect; the effect itself is expressed by the goal. In (7), an implication of power misuse is possible if the undergoer of the upper action tier assigns the subrole of malefactive, but for this interpretation, more contextual information is needed. The angled brackets around the minus of UN in structure (7) indicate the possibility of two readings of this UN: the neutral UN or the malefactive (UN-).

(7) *Joka perjantai johtaja pesetti Matilla autonsa.*

Every Friday boss wash-caus-past-3sg Matti-ade car-acc-px3sg  
 ‘Every Friday, the boss had Matti wash his car.’

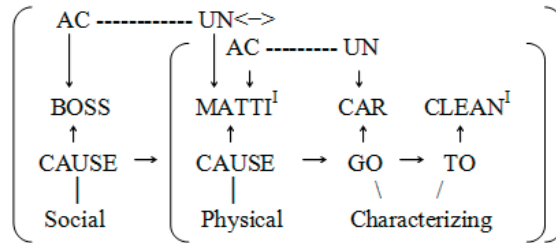

The actor in the upper action tier has two candidates for the role undergoer: MATTI and CAR (compare this to example (6) in section 4.1.2 in connection with the discussion about multiple undergoer- candidates for the actor in the upper act-chain). A variance in (7) is that for the power misuse reading, the suffering of MATTI is emphasized and this argument is assigned the role malefactive; it may be seen as a marked undergoer, significant to the semantic reasoning of the sentence. Hence, through the constructional reading, the action tier roles may freeze. An additional argument for the higher position of the SAR to the undergoer role instead of the theme argument CAR is its animacy. Consequently, it can be argued that if one of the possible undergoer candidates is able to assign a subrole of UN, the argument of this subrole is selected as the undergoer in this action tier before the neutral candidates of UN. This hypothesis of a hierarchy in the selection of possible undergoers is formalized in (8):

## (8) UN-/UN+ &gt; UN

The power misuse reading can thus be seen as a *possible* pragmatic interpretation pattern. The verb *pesettää* ‘make s.o. wash’ does not require this sense; the activity in (6) can describe a quite neutral routine (it is part of Matti’s job to wash the car) or even a beneficial situation (it is positive that the boss has arranged a job for Matti). Since it is characteristic of Finnish culture that a leader should follow certain social norms, a deflection of good manners is noticed. The power misuse implication releases the malefactive reading, which makes the double-causative verb suitable for the PMC reading. The interpretation rule is closely related to the interaction: people are talking about people and assessing one another’s activity. The PMC is an evaluation of the quality of the relation between the SAD and the SAR: is the effect of the dominance on the SAR positive, neutral or negative? In my opinion, interpretation constructions enable us to express the relevant content in a compact, recognizable and expressive way.

In summary, the essential aspects of the evaluative PMC construction are certain contextual cues leading to the PMC reading. Firstly, there is a reference to a social hierarchy in terms of a scale of power (more or less influence on the situation in question). We can even say that the critical stance questions the hierarchy through the indication that the SAD's behavior does not follow the accepted social or moral principles connected with the influential position. Secondly, the following features of the malefactive SAR affect the reading: the SAR's activity has no purpose, and typically the SAR is not aware of the abuse. From these aspects arises the accusatory attitude, which strengthens the PMC reading. A question is whether the increase in patient properties of the SAR contributes to the accusatory implication. Recall the discussion on agent-patient entailments in relation to CSD arguments in section 4.2 – the theme-SAR lacks the ability to cause another event or state in another participant, unlike the causer-SAR. Hence the theme-SAR has less control over the situation denoted by the root verb than the causer-SAR. Is the single-causative prototype disposed to a power misuse implication?

### **5.3 Other constructions with social implications**

Based on the material from language use, my aim in this section is to show that there are further patterns related to the social dimension characteristic of *ttA*-causatives. In terms of the PMC, we will see that some of this construction's criteria can be abandoned, with the result that diverse variations emerge in the dominance pattern. The constructional phenomena discussed in 5.3 differ from the PMC in that the SAD is not necessarily a person but, for instance, (social) events or psychological/physiological states; the properties of the animate SAR will come into focus. The question highlighted here is how the changes in the argument structure affect the CSD proposition. The verbs in the analysis below are all able to be applied to at least one of the prototype CSD structures, and occur additionally in other constructional circumstances.

### 5.3.1 Responsibility Shift Construction

This section examines a construction slightly different from the PMC. Here also the aspects related to the power relationship are important. Consider the following example with the causative verb *syötättää* ‘make s.o. eat’ in a proposition with only one animate argument:

(1) *syötättää* [eat-caus-caus] ‘make s.o. eat’

*Varsinkin varhainen hylätyksi tulemisen kokemus tuo sisällemme syöjättären. Se on olemisen malli, jossa ratkaistaan piilotajuisia ongelmia syömällä. Sisällämme oleva pettymys syötättää meitä.*

‘Early experience of abandonment in particular awakens the eater in us. It is a model of existence where subconscious problems are solved by eating. Inner disappointment **makes** us **eat**.’

(<http://users.kymp.net/olmoi/paa/kurssi/kurssiku.html>, 22.3.2006)

The significant semantic aspect in proposition (1) is that the typically self-oriented activity of eating in this example is not under the control of the actor-SAR (the eater or ‘we’). The SAR is the performer of the action denoted by the root verb *syödä* ‘to eat’. A stimulus on the mental level (the disappointment) has the power to control the SAR’s activity, even more so; this power is explicitly transferred away from the SAR in this proposition. The fact that the SAR is likewise the only +human participant capable of consciousness and control involved in this proposition emphasizes the control transition reading. The situation is exposited so that preventing the action (eating) from happening is not within the power of the SAR. The proposition in (1) is thus at variance with the prototypical idea of agentivity as proposed for instance by Dowty (1991) about an active agent and a patient that undergoes a change (recall the discussion of the types of causation in section 2.5 and the agent properties of CSD arguments in 4.2); the agent properties in this example are not distributed according to this archetypal concept. The only agent, the SAR, is sentient and exists independently of the event expressed by the verb; however, it is not a volitional or intentional actor. In example (1), the participle structure *sisällämme oleva* [inside-ade-px1pl be-1ptc] ‘(the) inside us existing’, adds a nuance of interminability to the situation; the first participle in the active voice expresses a continuous, incomplete situation (ISK §524).

The conceptual structure analysis of control shift proposition (1) is given in (2). In order to simplify the analysis, I abandon the original participle structure and keep only the relevant part of it, the head of the phrase. Function *f* stands for  $f > 1$ . The partitive object case in (2) indicates that the situation is unbound (recall the discussion on aspectual object case marking in Finnish in 3.1.1); the sentence expresses a continuous and incomplete situation in the sense that the action extends over a period of time.

- (2) *Pettymys syötättää meitä*  
 disappointment eat-caus-caus-pres-3sg we-part  
 ‘Disappointment makes us eat.’

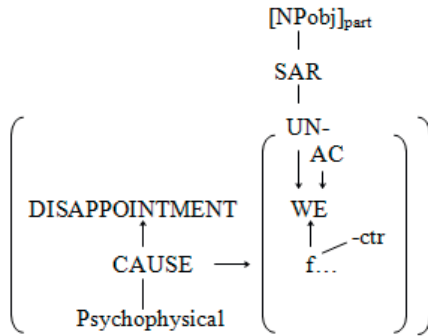

The SAR's complete lack of control in this structure is expressed by the negative control feature (-ctr). I link the semantic feature of control to the unspecified thematic function *f*; the argument of the function linked with *ctr* has control over the situation expressed by the function, and in the case of the negative control feature, the argument lacks control. This analysis is analogous to the solution in Pörn (2004: 61), where the semantic feature 'uncontrolled' is linked to the causation expressed by a subordinate clause. Pörn relates this feature with volitionality, assuming that a volitional act cannot be interpreted as uncontrolled; the situation in this case is controlled. I agree that a non-volitional act is normally uncontrolled; at least in example (2) we can say that the SAR referent does not particularly want the situation expressed by the root verb to happen. Therefore, I do not mark the feature '-volitional' separately in (2) (compare this to section 3.3.2, where volitionality was argued to be the default case in connection with the verb *syötättää* 'make s.o. eat').

The complexity of the semantics related to the verb 'to eat' was also discussed in connection with the linking relation between the syntactic and conceptual arguments in section 3.3.2, where I came to the conclusion that it is complicated to define a single semantic field to describe all of the different processes related to the eating process. In the conceptual analysis of the construction analysed here I concentrate on the properties relevant to social relations. At least in (2), the pattern seems to rule out some potential aspects (nutritional, physiological, social etc.) and focus instead on the negative outcome of (over)eating. On the action tier level, the SAR, like the PMC, is linked to a double-roled argument: it is assigned both the role malefactive on the upper action tier and actor on the lower action tier. The negative effect of the abstract causer (the SAD) on the malefactive SAR and the explicit abandonment of the control feature emphasise the distress of the SAR. The

structure only includes the relevant aspects for constructional interpretation; the implicit argument normally related to the verb ‘to eat’ i.e. ‘food’ is not expressed.

Configuration (2) differs from prototype CSD patterns in several aspects. I thus assume that there is an exceptional pattern behind this and call it here the ‘Responsibility Shift Construction’ (the RSC). This construction transfers control completely outside of the activity denoted by the root verb, removing responsibility for a normally self-agentive action from the actor to an intangible causer. The performer of the action (the SAR) strives to avoid the action the root expresses. The causer argument is typically a (physical/psychological) stimulus that leads to the situation that the SAR experiences as negative. I mark the semantic field in zone 3 as ‘psychophysical’, because the stimulus takes the event in a certain direction in the SAR’s thoughts. As the animate participant, the SAR argument has the ability to reflect on the situation, but at the same time has no control over the thoughts which lead to the uncontrolled activity. Does psychophysical causation differ from social in that the latter typically involves two individuals (or groups of individuals)? I leave this issue for further research. I do not define the semantic field of the root verb structure; it can be noted that the activity of the SAR argument involves at least mental, spatial and social aspects. Syntactically, the SAR is expressed as the partitive object, which focuses on the incomplete atelic process without change; I assume that the partitive object is the syntactic characteristic of this construction. The conceptual structure of the RSC is analyzed in (3):

### (3) Responsibility Shift Construction

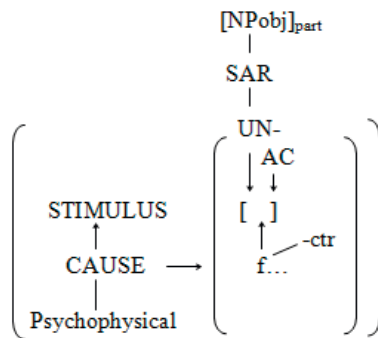

As a comparison, consider an example with a physiological reason. In example (4), the causation argument *olut* ‘beer’ represents the whole event of the drinking action with the biological effects on the drinker’s body.



(4) *syötättää* [eat-caus-caus] ‘make s.o. eat’

*Olut kiihdyttää lisäksi ruokahalua ja syötättää vielä seuraavanakin päivänä, sanoo tiedotuspäällikkö Riitta Rantanen.*

‘Moreover, beer whets your appetite and **makes** you **eat** even the next day, says head of information department Riitta Rantanen.’  
([http://lehti.keskisuomalainen.fi/sl/1997-08/08/pre/stt\\_219.htm](http://lehti.keskisuomalainen.fi/sl/1997-08/08/pre/stt_219.htm), 7.01.2009)

The SAD referents in the Responsibility Shift Construction are limited to those that agree with the (physiological or mental) STIMULUS. By way of comparison, consider a sentence with a +human SAD: *Äiti syötättää lasta*<sup>55</sup> ‘The mother has the child eat’. In terms of corresponding to the RSC, this sentence is odd. The construction effects the interpretation of the situation so that the presence of the mother makes the child eat, regardless of the child’s will. The essential aspect of this construction is that it places certain semantic requirements on the root verb as well, and modifies its properties. A precondition of this construction is that the root verb should be a verb with a semantic feature control (ctr) in its LCS. Verbs like ‘to eat’ and ‘to drink’ are typical examples. The construction erases the ctr-feature. Consider the following sentence:

(5) *Huono keli liukastutti jalankulkijoita*

Bad weather slip-caus-past-3sg pedestrian-pl-part  
‘The bad weather saw pedestrians falling over.’

This sentence contains no responsibility shift, because the verb *liukastua* ‘to slip, fall’ does not include a control feature. This feature is not always a lexical feature; it may be dependent on the arguments involved. The possible ways of testing the verbs for the feature control are for instance their applicability to the imperative modus or in the frame of the verb *päittää* ‘to decide’ (6):

(6) X *päittää* V<sub>inf</sub>  
‘X decides to V.’

Using these tests we can see how the verbs behave in respect of the feature control; see (7-8). The (#) indicates that the verb in question is not ungrammatical in the constructions in question. The situations that verbs like

<sup>55</sup>Note that the CSD *syötättää* (eat-caus-caus) includes two *ttA*-morphemes. The situation of a mother feeding her child in Finnish is expressed with the verb *syöttää* (eat-caus), a single *ttA*-causative: *Äiti syöttää lasta* ‘The mother feeds the child’. The use of the verb *syötättää* seems to be associated with relatively new problems in human history related to eating and nutrition i.e. food becoming superfluous whereas the normal state has been a paucity of food.

*liukastua* ‘to slip, fall’ or *hämmästyä* ‘to be astonished’ refer to are not controllable (except for contexts in which they can be thought of as controlled, as in a situation where the action is not genuine but a conscious pretence, like acting).

(7) *Syö!* ‘Eat!’/ *Kävele!* ‘Walk!’//*#Liukastu!* ‘Fall over!’/ *#Hämmästy!*  
‘Be astonished!’

(8) *Timo päättää syödä / kävellä / #liukastua / #hämmästyä*  
‘Tom decides to eat / walk / #fall over / #be astonished.’

Responsibility Shift Construction verbs include properties analogous to ‘causative emotion verbs’ in Finnish (fi. *tunnekausatiivi*). The causative morpheme *ttA* is also used to derive causative emotion verbs. The additional shared property is the characteristic argument structure: the experiencer of the state of emotion is syntactically not expressed as the subject but as the object. The experiencer is a semantic role that perceives, thinks or feels something, typically an animate being whose consciousness is affected by the expressed situation. (For causative emotion verbs, see for instance Siirainen 2001 or Pörn 2004 & 2007.) Since these verbs can also generally behave as general transitive verbs, Siirainen (2001) treats the special argument structure of causative emotion verbs as a constructional phenomenon; the ‘emotive causative frame’ (fi. *tunnekausatiivikehys*) is OV(S) with the central element of the experiencer of the emotion that is syntactically encoded as the object. Examples (9a-b) are of the emotive causative verb *pelottaa* ‘make s.o. scared’. Example (10a) includes the cause of the state of the emotion, syntactically expressed as the subject; example (10b) lacks a cause.

(9a) *Peteä pelottaa naapurin koira*  
Pete-part scare-caus-pres-3sg neighbour-gen dog-nom  
‘Pete is scared of the neighbor’s dog.’

(9b) *Peteä pelottaa*  
Pete-part scare-caus-pres-3sg  
‘Pete is scared.’

Hence the RSC has similar features to the emotive causative frame. The SAR in both cases is expressed as the partitive object, but the semantics of the SAR in the responsibility removal are more complex; it is assigned the action tier roles actor and malefactive, but at the same time it is also the experiencer. In the emotive causative frame, the emotion happening to the experiencer is beyond its volition and control (Siirainen 2001: 72); this is the case of the RSC experiencer as well. Consider examples (10-12) with *syötättää*, *juotattaa* and the triple-*ttA* verb *syötättyttää*.

- (10) *syötättää* [eat-caus-caus] ‘make s.o. feel like eating’

*1980-luvun puolivälissä minua alkoi kovasti syötättää, hän nauraa. – Lautanen oli pakko täyttää ääriään myöten ja myös makea maistui. ‘During the mid-1980’s I really **felt like eating**, she laughs. I felt compelled to fill up the plate and had a sweet tooth.’*  
(<http://www.terveyshymin.fi/artikkelit/aminohappovalmistevai-nalan-tunteen>, 7.1.2009)

- (11) *juotattaa* [drink-caus-caus] ‘make s.o. feel like drinking’

*Ihmiset juovat, kun juotattaa ja on ongelmia sekä ahdistaa - juovat tuskaansa.*  
‘People drink when they **feel compelled to drink** and have problems and are distressed – they drink to drown their pain.’  
([www.hs.fi/keskustelu/post!reply.jspa?messageID=1447857](http://www.hs.fi/keskustelu/post!reply.jspa?messageID=1447857), 7.1.2009)

- (12) *syötätyttää* [eat-caus-caus-caus] ‘make s.o. feel like eating’

*(Elisan ruokapäiväkirja) Huh Huh. Tänään on tiistai... eikä suju yhtään hyvin. Kokoajan syötätyttää... ja pisteetkin on paukkuneet jo niin yli ettei ole tosikaan...*  
‘(Elisa’s food diary) Oh. Today it’s Tuesday... and it’s not going well at all. I **feel like eating** all the time... and I’ve had too many points already. I can’t believe it...’  
([www.eu.gw.com/laihis/elisa17.html](http://www.eu.gw.com/laihis/elisa17.html), 7.1.2009)

Pörn (2004) argues that causative emotion verbs express not states but events i.e. dynamic situations; she analyses the conceptual structure of the emotive causative frame using the event-function STAY. Also, P. Leino (1986: 119) suggests that emotions are conceptualized in the semantic system of Finnish as activities rather than states. There are differences between emotive causatives depending on their LCS: there are both optionally and compulsory causative verbs (Pörn 2004, 2008). Compare examples (13a) and (13b), the conceptual structures of sentences with the emotion causative *pelottaa* ‘make s.o. scared’ and *syötätyttää* ‘make s.o. eat’ respectively. How do these conceptual structures differ? I assume that the difference lies in the action tier: the emotion causatives do not include action tier roles. Note that in these constructions the verb form is in the 3<sup>rd</sup> person. Is the semantic feature ‘uncontrolled’ (-ctr) included by default in connection with the emotion causatives?

- (13a) *Peteä pelottaa naapurin koira*  
 Pete-part be.scared-caus-pres-3sg neighbour-gen dog-nom  
 ‘Pete is scared of the neighbor’s dog.’

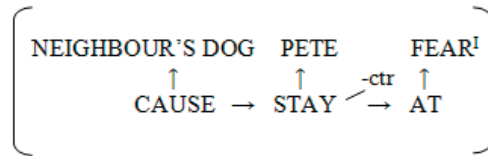

- (13b) *Minua syötättyttää*  
 I-part eat-caus-pres-3sg  
 ‘I feel like eating.’

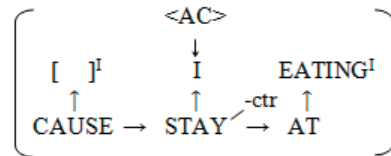

The differences between these verbs become apparent when we add a subordinate clause to them. The activity of the root verb in (14b) is concrete and has a starting point and an ending point, but in (14a) it is abstract with no implication of temporal boundaries. Example (14a) expresses a continuous state or even a general property of ‘Pete’, and the consequence of the activity in the main clause is the continuation of this state. In (14b), the temporary situation ends with the result expressed by the subordinate clause.

- (14a) *Peteä pelottaa naapurin koira, joten hän pelkää.*  
 Pete-part be.scared-caus-pres-3sg neighbour-gen dog-nom so he-nom  
 be.scared-pres-3sg  
 ‘Pete is scared of the neighbor’s dog, so he (Pete) is scared.’

- (14b) *Minua syötättyttää, joten syön.*  
 I-part eat-caus-caus-caus-pres-3sg  
 ‘I feel like eating, so I eat.’

Pörn (2008) argues that the [causative emotion verb + infinitive 1] construction is not acceptable in connection with purely physical causative emotion verbs. The derivatives *syötättää* and *syötättyttää* seem to relate to physical causative emotion verbs in this respect. Compare the infinitive structures in (15a) and (15b):

(15a) *Mattia pelottaa syödä*  
 ‘Matti is scared to eat.’

(15b) \**Mattia syötättää mennä/juoda/pelätä*  
 ‘Matti feels so much like eating that it is forcing him to go /  
 driving him to drink/scaring him.’

The three causative derivatives of *syödä* ‘to eat’ (*syöttää*, *syötättää* and *syötätyttää*) are verbs with flexible argument structures. All of them are used in my material as prototypical CSDs, corresponding to the analysis of medium transitive verbs in section 3.3.2. The conceptual structure analysis of example (16a) in (17) thus applies to all of the examples (16a-c). Note that structure (17) includes the implicit theme (FOOD).

(16a) *syöttää* [eat-caus] ‘make s.o. eat, feed s.o.’

*Ministeri syöttää pappeja*

‘The minister **made** the priests **eat** (fed the priests).’

(<http://uutisblogi.blogit.kauppalehti.fi/2007/02/20/keisarin-veroissakinon-tarpeeksi/>, 7.1.2009)

(16b) *syötättää* [eat-caus-caus] ‘make s.o. eat’

*Kekkosen valta oli suuri, muttei rajaton. Ylintä valtaa Tamminiemessä käytti emäntä, joka syötätti presidentillä erilaisia maksaruokia, vaikka miespolo inhosi maksaa.*

‘Kekkonen’s power was great but not without its limits. The supreme power in Tamminiemi was used by the lady of the house, who **made** the president **eat** various liver dishes, even though the poor man hated liver.’

(<http://kemppinen.blogspot.com/2008/11/murroskohdist.html>, 7.1.2009)

(16c) *syötätyttää* [eat-caus-caus-caus] ‘make s.o. eat/feed’

*Koska olet yltiömaterialisti ja pelkääät kuolemaa ja uskot rahan kaikkivoipaisuuteen, niin eikö silloin sinun kannaltasi olekin parempi, kun aktiivinen eutanasia-laki toteutetaan, koska siten säästyy rahaa siihen, että sinä maat (pro: saat) makuuttaa, syötätyttää, vaipotuttaa ja ylösnostatuttaa itseäsi vaikka ikijäähän asti*

‘Because you are a fanatical materialist and afraid of death and believe in the omnipotence of money, would it not be better for you if the euthanasia law was passed, since it would save money so that you could have [the nurses] let you lie in bed and **make** [them] **feed** you, make

[them] put you in diapers and make [them] get you up?  
 (http://keskustelu.suomi24.fi/show.fcgi?category=114&conference=450000000000038&posting=22000000008910890, 20.12.2005)

(17) *Ministeri syöttää pappeja*

‘The minister **made** the priests **eat** (fed the priests)’

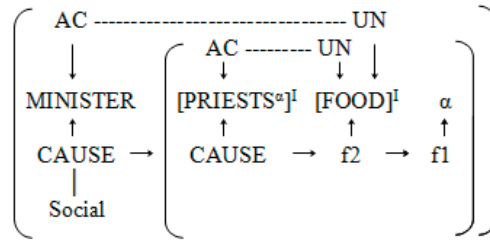

The single-*ttA* derivatives of *syödä* ‘to eat’ and *juoda* ‘to drink’ have lexicalized meanings (*syöttää* ‘to feed, fatten’; *juottaa* ‘to give s.t. to drink, to water, to give s.o. a drink’ according to KS). The derivatives of these verbs with two and three *ttA*-morphemes (*syöttää*, *syötättyä* and *juottaa*, *juotatuttaa*) can be used both in the Responsibility Shift Construction and in the emotive causative frame. Based on observations of the data in my material, my rough estimate is that there is the following distributional tendency: the morphological variants of two causative morphemes (*syöttää*/*juottaa*) are more general responsibility shift verbs, while the variants of three causative morphemes (*syötättyä*/*juotatuttaa*) are used as causative emotion verbs. I assume that morpho-phonological aspects have an effect here: the morpheme *UttA* in particular attracts emotive causatives. According to Siirinen (2001: 72), emotive verbs in Finnish are either stative denominals (like *harmi* ‘annoyance’: *harmittaa* ‘to annoy’) or derived from *-(i)stu-* inchoatives (*harmistua* ‘to get annoyed’: *harmistuttaa* ‘to annoy’). Does the last type function as a core, attracting new causative emotion verbs to its group? Another explanation could be that since two different constructional meanings are available for *ttA*-causatives, the two relatively similar lexemes tend to specialize in one of them. Thus, even if these verbs can occur in each of the abovementioned constructions, the form of the causative morpheme has an influence on their use. Examples with *juottaa* and *juotatuttaa* are presented in (18a-b):

(18a) *juotattaa* [drink-caus-caus] ‘make s.o. drink’

*Mitä enemmän pyrimme tälle hengelliselle tielle, sitä enemmän  
 Paholainen tarrasi kiinni. Se juotatti kahta kauheammin!*

‘The more we tried to achieve this spiritual way, the more the

Devil got hold of [us]. This **made** [us] **drink** twice as much!’  
(<http://www.rukousystavat.fi/mparan.html>, 7.1.2009)

(18b) *juotatuttaa* [drink-caus-caus-caus] ‘make s.o. feel like drinking’

*Kaamos, mä en tykkää tästä pimeästä ajasta, märästä, loskasta, liukkaasta. Nukuttaa, syötätyttää, juotatuttaa.*

‘Darkness – I don’t like the dark period. It’s wet, slushy, slippery. I’m sleepy. I **feel like** eating and **drinking**.’

(<http://www.verkkoklinikka.fi/?page=1069820&m=9070188f=3651809&c=438407&t=5756088&tree=1&seuraaminen=end&t=5756088>, 7.1.2009)

It should be noted that verbs with the feature ‘uncontrolled’ (-ctr) can be used in situations expressing controlled activity if the context is suitable. Compare sentences (19a) and (19b) with the verb *kompastuttaa* ‘make s.o. stumble, trip’:

(19a) *kompastuttaa* [stumble-caus] ‘make s.o. stumble, trip’

*Paluu sorvin ääreen jälleen. Viikonloppu kompastutti taas, onpa kumma!! Se oli kyllä jo tiedossakin että tulee olemaan hankalaa painontarkkailun suhteen, oli rippij-uhlaa, parin päivän musiikki-tapahtumat kaupungilla ja siitä seuraavat krapula syömingit. Surkea tapaus kyllä!*

‘Come back to the lathe again. The weekend **tripped** [me] **up** again, big surprise!! I knew it would be tricky with the weight- watching; there was a confirmation party, a couple of days with music events in the city followed by hangover eating. A miserable situation!’

([http://64.233.183.104/sein,search?q=cache:4CKKXWmIDzYJ:www.terhi.info/keskustelut/viewtopic.php%3Ft%3D1537%26view%3Dprevious%26sid%3D8a39b1f40097f70b867c398f5a092f0+kompastutti&hl=fi&gl=fi&ct=clnk&cd=10&lr=lang\\_en|lang\\_fi](http://64.233.183.104/sein,search?q=cache:4CKKXWmIDzYJ:www.terhi.info/keskustelut/viewtopic.php%3Ft%3D1537%26view%3Dprevious%26sid%3D8a39b1f40097f70b867c398f5a092f0+kompastutti&hl=fi&gl=fi&ct=clnk&cd=10&lr=lang_en|lang_fi), 5.3.2009)

(19b) *Ohrake juoksi meidän perässä, kun rosvot juoksi suoraan kohti hoitolan pihaa. Pihalla Pimu juoksi niiden eteen, ja kompastutti ne.*

‘Ohrake ran after us, while the robbers ran straight towards the yard. In the yard, Pimu ran out in front of them and **tripped** them **up**.’

(<http://www.shinybook.net/book/?vk=4523&act=index&sivu=2>, 5.3.2009)

Consider also the verb *purettaa* ‘make s.o. Bite’, which behaves in a rather special way in respect of the control feature. The activity of an animal is not completely controllable, but to a certain degree predictable. Examples (20a-b) express a controllable situation; in (20a), the guard has the behaviour

of the dog under his control, while in (20b) the researcher lets the snake bite him on purpose. Snakes are not trainable in the same way as dogs, but for instance in a situation where a snake is purposely allowed to bite someone, the biting activity can be controllable. Examples (21a-b) express uncontrollable situations; (21a) a hypothetical situation; and (21b) an accident.

(20a) *purettaa* [bite-caus] ‘make s.o. bite’

*Vartija puretti koiralla varasta* (ctr)  
Guard bite-caus-past-3sg dog-ade thief-part  
‘The guard **let** the dog **bite** the thief.’

(20b) *Tutkija puretti sihteeria käärmeellä*

Researcher bite-caus-past-3sg secretary-part snake-ade  
‘The researcher **let** the snake **bite** the secretary [on purpose].’

(21a) *Tässäkin harjoituksessa on vaara purettaa itsensä, mikäli koiralla on taipumuksia herkästi puolustautua puremalla /--/ (-ctr)*

‘Also in this exercise there is a danger of **getting bitten**, since the dog tends to defend itself by biting.’

([http://koti.phnet.fi/pretty/yksin\\_kotona.htm](http://koti.phnet.fi/pretty/yksin_kotona.htm), 27/9, 2004)

(21b) *Tutkija puretti itseään käärmeellä* (-ctr)

Researcher bite-caus-past-3sg self-part snake-ade  
‘The researcher **let** the snake **bite** him [he was not careful enough].’

Returning to the Responsibility Shift Construction, it appears that this construction also has a strong connection to contextual information and the communicative situation, as with the Power Misuse Construction. The speaker transfers the power (control over the situation) away from the participant normally accountable for the activity in order to convince the listener in the proposition that “it is not the SAR’s fault that they are carrying out the activity expressed by the root”. The SAR typically performs a (self)harmful action, but cannot, in the speaker’s assessment, be held responsible for it. This interpretation of the situation launches the interpretation construction. This special perspective is linked to social conceptualization via interaction. The interaction between the communicative situation and the linguistic-conceptual levels can be seen in Figure 4:



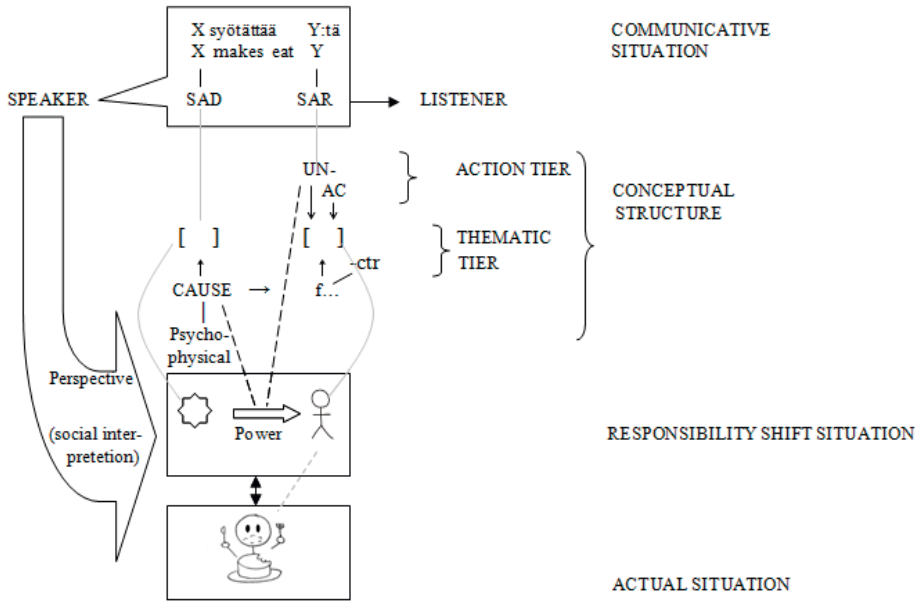

Figure 4. Responsibility Shift Construction and communicative situation

The interpretation constructions thus delimit some of the functions the CSDs have in language use; they reflect what speakers do with these verbs. As such, by means of formal analysis and specific language material, the interaction can be approached bottom-up. A function of the CSDs appears to be assessing the aspects of conventionally responsible behaviour. The discussion in the next section continues the examination of this concept of responsibility.

### 5.3.2 Aspects of responsibility: the responsible SAR and psychosocial causers

The interpretation constructions discussed above raise questions about the nature of responsibility in language. How are causation and responsibility related to each other? How is responsible activity manifested in language? How does language reflect well-founded activity or an activity that does not follow social standards? I assume that the semantic features related to causation and agentivity like control, volitionality, consciousness and participation are influential aspects in the concept of responsibility. The underlying factors in the expressions assessing responsibility are connected with the actors: who does what, how do they do it and why? This builds a link to pragmatic phenomena like attitudes and perspectives. Responsibility is

obviously a phenomenon related to the relationship between humans and human activity in society<sup>56</sup>. A human causer is expected to act responsibly and to take responsibility for his actions. The notion of a responsible action presupposes that the actor has control over the situation; the actor is able to govern the emergence of the situation (by doing something actively or preventing something from happening). In order to have control, the actor needs to be aware of the effects of the action. The notion of volitional action implies that the actor has a choice (freedom of choice), which also presumes awareness of the actor.

I would argue that linguistic phenomena like CSDs provide speakers with tools to display the concept of responsibility. The Responsibility Shift Construction discussed in the previous section shows that even if derived recursively with more than one *ttA*-morpheme, CSDs do not automatically express only the (compositional) proposition of the action of the human SAR caused by the human SAD. It is also obvious that the RSC is not the only alternative in expressing a CSD proposition where the activity of the SAR is brought about by an abstract phenomenon or concrete event. The emotive causative verb construction was mentioned in the previous section as a pattern semantically and morpho-syntactically close to the RSC. In this section I will introduce some further variants of CSDs in connection with non-human causers. Here also, the aspects related to the social dimension are important. We will discuss a structure similar to the RSC but with a different perspective on the actor characteristics.

Firstly, consider example (1) using the CSD *äänestyttää* ‘make s.o. vote’, where the causer referent of the SAR’s action is a (social) phenomenon. The only AC-role is assigned to the second causer argument, which is also linked to the SAR.

- (1) *Ympäristöasiat äänestyttävät kansalaisia*  
 environmental.issue-pl vote-caus-pres-3pl citizen-pl-part  
 ‘Environmental issues get citizens voting.’

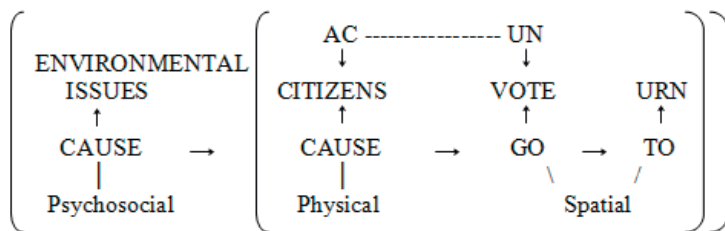

<sup>56</sup> The definition of the word ‘responsibility’ in WordNet is the following: 1. the social force that binds you to the courses of action demanded by that force; 2. the proper sphere or extent of your activities; 3. a form of trustworthiness; the trait of being answerable to someone for something or being responsible for one’s conduct (<http://wordnetweb.princeton.edu>).

Unlike the RSC, the SAR (CITIZENS) in (1) acts volitionally and controls the action. We can even say that the effect of the causative event is boosting the responsiveness of the SAR; it forces the SAR referent to take responsibility. Paraphrased, example (1) could be ‘Citizens actively vote because environmental issues concern them’. Thus, the SAR is a conscious actor. The conceptual structure in (1) has two CAUSE-functions and corresponds to a large degree to double-causative objective actor prototype PT2.1 (see section 3.4). A difference to the prototypical action tier configuration of CSDs (see section 4.1.2) is that instead of two action tiers, there is only one; the first causer is not assigned the role actor, since its argument, ENVIRONMENTAL ISSUES, cannot be said to be actively doing anything. The SAR is the only human participant in this proposition. It is assigned the role AC and has the agent features required of a responsible agent. If compared to the RSC, this is a reverse situation: the RSC erases the agent properties of the SAR, but in (1), the agent position of the SAR is emphasized.

What leads the SAR to the responsible activity? The SAD in (1) refers to a certain discourse within society, which raises a question about the semantic field of the first causation. The information flow and discussion about a topical issue is social as such, but what has the SAR act is awareness of this topic, which is the result of a mental process. To indicate the mental effect of the SAD on the SAR’s awareness, I mark the semantic field of causation in (1) as ‘psychosocial’.

The non-human causer in the next example refers to an annual exercise event for women known as *Naisten Kuntovitonon*<sup>57</sup>. The conceptual structure in (2) corresponds to single-causative CSD-prototypes, but as with the previous example, the structure lacks the upper action tier. The argument linked to the SAR is encoded as a generic argument (marked as ARB in (2)), with the restriction that the SAR referent is participating in the event causing the activity and is female. The participants in this event can be said to be aware of the positive effects of the event indicated by the causer argument, which influenced their decision to take part in the event. The causer argument refers to a social event; thus, I also mark the semantic field of the causation zone here as ‘psychosocial’.

---

<sup>57</sup>According to the website, this is a relaxed event where the actual sports are walking, jogging, running or Nordic walking <http://www.naistenkuntovitonon.fi>).

(2) *Naisten Kuntovitonon kävelyttää*

”Women’s Shape.Five walk-caus-pres-3sg

‘Women’s Shape Five gets [women] walking’

(Blog headline of sports doctor Olli J. Heinonen)

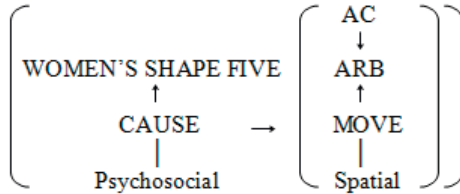

Example (3) comprises the general ‘make s.o. do’ verb *teettää*. This verb builds a collocative phrase with the partitive object *teettää töitä*, meaning roughly ‘cause s.o. to work’. Also in this example, the SAR is encoded as an implicit, generic argument.

(3) *teettää töitä* [do-caus work-part] ‘make s.o. work’

*Tasaisen tarjonnan aikaansaaminen läpi vuoden teettää töitä. Järvessä uivia kaloja ei voi ryhtyä myymään ennakkoon, vaan asiakassuhteita on luotava moneen suuntaan. Säätkin tekevät välillä omat temppunsa, sillä huonoilla keleillä ei aina saa kalaa tai pääse kalavesille.*

‘Regular supplies throughout the year **keep us working** (make [us] work). You can’t start selling in advance, but relations with customers have to be built up in lots of directions. Also, the weather plays tricks on you sometimes; when it’s bad, you don’t always catch fish, or even make it out into fishing waters.’

(<http://www.lansi-savo.fi/Uutiset/8380214.html>, 2.2.2009)

A conceptual structure analysis of a sentence analogous to (3) is given in (4). The theme argument (‘work’) is not specified in (4), because it forms part of a phrase that does not refer to any particular activity. Also here, I define the cognitive background as ‘psychophysical’: an event (a conference) affecting the non-specified participant. The impersonal construction thus leaves the doer of the action unspecified; however, the arbitrary actor is aware of the duty the causer referent indicates.

- (4) *Konferenssi teettää töitä*  
 conference do-caus-pres-3sg work-pl-part  
 ‘The conference gets us working.’

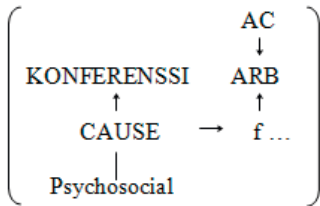

The conceptual structure of the non-human causer and the arbitrary actor construction can be called the ‘Responsible SAR Construction’. The structure of it is formalized in (5). The only active (and responsible) participant is the generic argument (ARB) linked to the SAR. Function  $f$  stands for  $f > 1$ . The construction applies to both double- and single-causative CSD propositions, with the condition that there is only one action tier.

- (5) Responsible SAR Construction

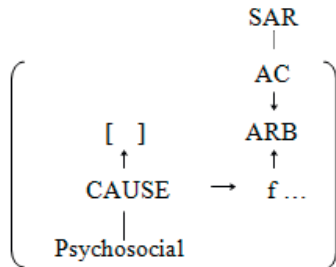

ARB in this construction means that the syntactic argument place of the SAR may be unfilled, as in examples (2-4). The 3<sup>rd</sup> person singular form in Finnish can be used in the generic sense, referring to a non-specified group of people or to the speaker (see for instance ISK §106). The SAR may also be linked to the object argument (as in example (1)) or the adessive adjunct, as in *minulla* [me-ade] in example (6a). Note that the SAR can even be expressed as the allative adjunct *henkilökunnalle* [staff-all] in example (6b):

- (6a) *Tuntuman hakeminen lihaksiin teettää minulla töitä tosi paljon.*  
 ‘Trying to get feeling into the muscles **makes me work** really hard.’  
 (<http://keho.net/keskustelu/naytaviesti/Ylaselan-treenaus-106264>,  
 3.3.2006)

(6b) *Jos kukkien hoito **teettää** liikaa **töitä** henkilökunnalle, perustetaan potilaiden viher-kasviryhmä, joka vastaa kukkien hoidosta.*

‘If tending to the flowers creates too much work for the staff (**makes them work**), let’s find a patient group responsible for greenery that will look after the flowers.’

([http://www.mielenterveys-taimi.fi/mielekas/2004\\_1/22.htm](http://www.mielenterveys-taimi.fi/mielekas/2004_1/22.htm), 3.3.2006)

Typically, in impersonal SAR expressions, the doer of the action is found by following contextual clues. Consider examples (7a) and (7b) with [X teettää töitä] ‘X do-caus-3sg work-part’, where the SAR is not explicitly expressed. We can reason from the contextual information that it refers to a group of people. In example (7a) these are either the unemployed themselves or the authorities working on the unemployment problem; it is not completely clear who the responsible actor is. In (7b), the generic SAR comprises the parents looking for the right car seat for their child. What is remarkable in these examples is that the work itself, syntactically expressed by a nominalization, is the cause of the activity. An implication of laborious and arduous activity is present in both examples.

(7a) *Työllistyminen **teettää** **töitä*** [headline, GP] *Työmarkkinoilla myllertää. Monilla aloilla kannetaan huolta työpaikkojen säilymisestä. Miltei samaan hengenvetoon muistutellaan, että työvoimasta tulee pian pulaa. Toisaalta meillä on vielä viime laman jäljiltä suuri joukko työttömiä, joiden paluu työelämään on takkuillut jo pitkään. Mitä rakenne-työttömyys on - ja mitä sille on tehtävissä?*

‘(Headline) Getting a job is a job and a half (**makes [one] work**) Times are tough on the labour market. There is concern about the survival of work places in many branches. And almost in the same breath, people are reminding us that there will soon be a shortage of labour. On the other hand, we still have a large group of unemployed people after the recession, who have had a long and troubled return to working life. What is structural unemployment – and what can be done about it?’

(<http://mikaeli.mikkeli.amk.fi/mikaeli/arkisto/tyoelama/tyollistyminen/>, 2.2.2009)

(7b) *Lasten turvaistuimia saatavilla melkoinen kirjo – oikean ja turvallisen vaihtoehdon valinta voi **teettää** **töitä**.*

‘There is a huge range of car seats available – choosing the right and safest option can be hard work (**make [one] work**).’

(<http://www.laaninhallitus.fi/lh/oulu/bulletin.nsf/9e5fbc22e706069bc2256bcc006f9b96/55178638b7b0194ec22571da0041e182?OpenDocument> 2.2.2009)

The verb *teettää* ‘make s.o. do’ is a verb that, in addition to the responsible SAR construction, also applies the Responsibility Shift Construction. The causer argument can be for instance the intake of drugs or alcohol or other addictive habits. It is crucial that as a result of the causation, the human participant has no control over their own actions; the power is completely the causer’s. The semantic field is then thus changed to the psychophysical, not the psychosocial as in connection with the responsible SAR construction in (8):

(8) *Tätä ne huumeet/se alkoholi teettää*

this-part this-pl drug-nom-pl / this alcohol-nom do-caus-pres-3sg

‘This is what these drugs/this alcohol do to you.’

Generally, constructions with a non-human causer as the subject argument are special in the sense that the subject argument is, in the default case, linked to the available human participant. In the examples above, the agent is linked to other types of complements or does not appear in syntax at all, and the abstract causer is mapped to the subject argument. Are constructions with an actor-object argument an exceptional phenomenon? CSD constructions seem to modify the agentive properties of the SAR in terms of control, consciousness and undergoing. In the next section, we will see a construction with a special point of view related to the SAD.

### 5.3.3 A lexical particularity: *tapattaa* ‘make s.o. kill’ and the responsible SAD

The verb *tapattaa* ‘make s.o. kill’ was discussed in section 5.2.5.1, with an emphasis on its temporal features and the effect of the spatio-causative adjunct. I will now focus on the aspects characterizing the social conceptualization and special lexical properties of this verb. Consider once more example (18) from section 5.2.5.1 with its conceptual structure in (1):

(1) *Kenraali tappatti sotilaitaan rintamalla.*

general kill-caus-past-3sg soldier-pl-part-px3sg front-ade  
 ‘The general got his soldiers killed on the front.’

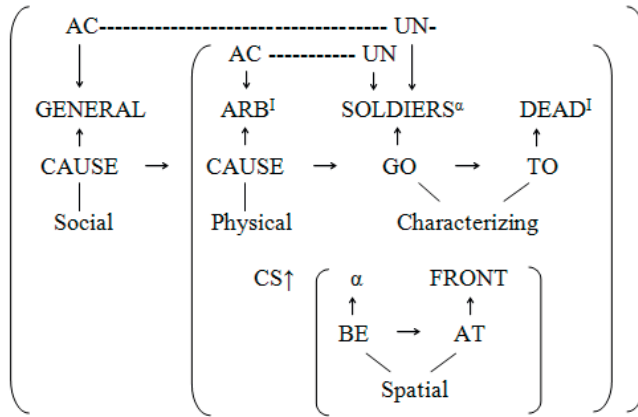

In proposition (1), the whole situation is characterised by a definitive and irreversible result for which the SAD (GENERAL) is held responsible. The root verb *tappaa* ‘to kill’ influences the reading of the effect in that the outcome of the situation cannot be fixed, repaired or replaced, as for instance in the causation event ‘to break a window’. The remarkable aspect here is that the first causer (GENERAL) is not actually *making* anyone kill the soldiers; it is most likely the SAR (‘the enemy’, marked as the implicit arbitrary causer in (1)) that does this; the general has not asked or forced the enemy to do so. However, the general is held *responsible* for the death of his soldiers – he made a wrong decision or just does not care. As was argued in section 5.2.5.1, the location phrase, ‘on the front’, expresses the causing event and refers to the place and circumstances in which the soldiers were killed. The spatial adjunct (‘on the front’) thus has an explanatory effect of the causes of the situation. The causative subordinate operator CS↑ describes the effect of the location phrase; because of spatially being on the front, the implicit causer argument is able to (physically) lead to the effect of the soldiers’ being killed.

The relevant aspect in connection with *tapattaa* ‘make s.o. kill’ is that the SAD does not control the situation completely; the activity of the SAR, the implicit causer, is not under the SAD’s control. However, the whole situation is brought out so that the SAD is considered to have the power to prevent the situation expressed by the rest of the LCS.



### 5.3.4 A verb applying several causative constructions: the case of *haetuttaa* ‘make s.o. fetch’

This section will focus on the verb *haetuttaa* ‘make s.o. fetch, bring’. I have chosen this verb because of its syntactic and semantic alterations, which are relevant regarding the concept of causation and agentive properties. This verb encodes complex mapping relations in terms of the argument-binding of the conceptual arguments (for argument-binding conventions in conceptual semantics theory, see section 2.2.1) as well as linking relations between the LCS and the syntactic arguments (for morpholexical and direct argument-linking, see 2.2.2).

The lexical entry of *haetuttaa* is given in (1). Since the derivatives *haettaa* [fetch-caus] and *haetuttaa* [fetch-caus-caus] are regarded as semantically identical (see Kytömäki 1978 and Karlsson 1983), I preliminary assume that the LCS (1) is valid for both verbs. The discussion below will specify further characteristics of this verb and the distributional variance between the derivative forms *haettaa* and *haetuttaa*.

(1) Lexical entry of the verb *haetuttaa* ‘make s.o. fetch’

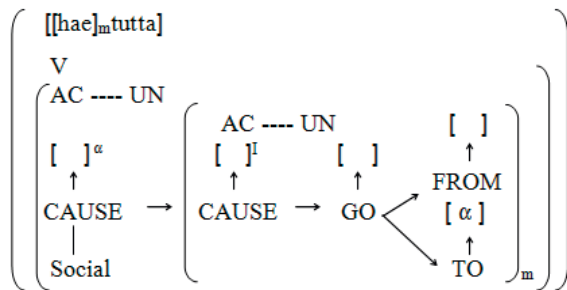

To begin, I will examine the lexical properties of *haetuttaa* and discuss variations in the argument-binding of this verb which have an effect on the social aspects of the situation. The LCS of *haetuttaa* corresponds to the adessive adjunct prototype of a double-causative, the PT1.1. A special characteristic of the root verb structure is the transfer of the theme argument from a place to the possession of the SAD (marked with the index  $\alpha$  in the CS). An example with the verb *haetuttaa* is given in (2); note that this example was also analyzed in connection with the temporal structure study (see (3) in section 4.3.2). The numeral indices in (2) indicate correspondence between the syntactic and conceptual constituents.

- (2) *Lauri*<sub>2</sub> *haetutti*<sub>1</sub> *Katjalla*<sub>4</sub> *kirjan*<sub>3</sub> *kirjasto*<sub>5</sub> *sta*<sub>6</sub>  
 Lauri fetch-caus-caus-past-3sg book-acc Katja-ade library-ela  
 ‘Lauri had Katja fetch the book from the library.’

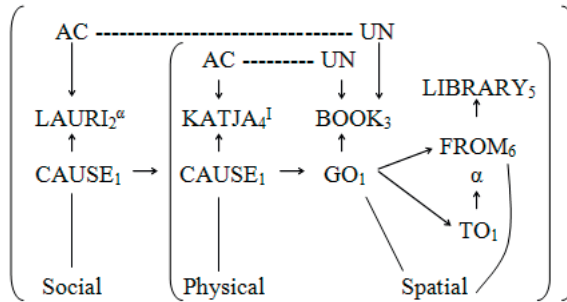

The indexing of the bound arguments within the LCS (with the Greek letter  $\alpha$  of the causer and receiver) as in (1) and (2) can be seen as the compositional case of *haetuttaa*. The LCS of *haetuttaa* hence reflects the pragmatic characteristics of it i.e. a deictic element: the theme referent is transferred to the possession of the subject argument, the SAD. However, this binding relation is not the only possibility in connection with this derivative. Consider example (3), where the theme argument is human, in addition to the SAD and SAR (this example is also analysed in section 4.3.2 in connection with the temporal analysis of causation). In (3), the theme argument is not transferred to the possession of the SAD (WIFE) but to a place (or implicitly to the possession of the arbitrary SAR). Thus, the perspective of fetching here is the SAR's, not the SAD's, and no indexing is needed. The sentence either notifies us of the location of LATE before the transition: we do not know if he has been where his wife lives or somewhere else (or with or without his wife being present). Therefore, the path-function FROM is not present in (3).

- (3) *Vaimo*<sub>2</sub> *juottaa* *Late* *sammuksiin* ja *haetuttaa*<sub>1</sub> *hänet*<sub>3</sub> *sitten* *putka*<sub>5</sub> *an*<sub>6</sub>.  
*Sen jälkeen vaimo suuntaa korkokenkensä kohti tanssiparkettia.*  
 ‘The wife gets Late drunk and] has him [then] carted off to jail. Then she puts on her high-heeled shoes and heads for the dance floor.’  
 (<http://plus.kaleva.fi/cf/juttu.cfm?j=336790>, 13.1.2005)

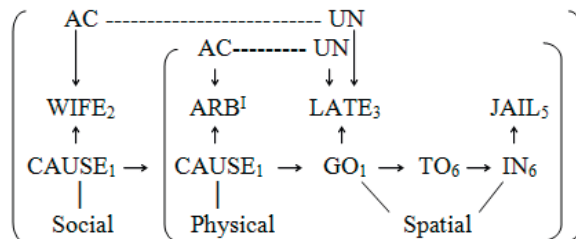

A third possible way of binding the arguments spread out in the conceptual structure in connection with *haetuttaa* is when the activity of the SAD is directed towards itself i.e. it is used as a reflexive. This is exemplified in (4a-b); (4a) includes the reflexive anaphora *itsensä* ‘itself’ whereas (4b) involves no explicit anaphora but is understood to be reflexive. I analyze the conceptual structure of example (4a) in (5). As in (1), the bound argument here is also the SAD (WOMAN) but in this case it is coindexed with the theme, the argument in transition. The theme is not transferred to the possession of the SAD but to a place (CHILDBIRTH). The semantic field of the transition of the theme in (5) is not purely spatial in the sense that an event happens after the spatial change (similar to the type ‘go to swim’); therefore, the semantic field is marked as ‘circumstantial’ in (5). The conscious activity directed towards itself, at least in examples (4a-b), can be seen as favourable to the SAD. Therefore, the undergoer in (5) is assigned the subrole beneficiary.

(4a) *Nainen<sub>2</sub> vei harhautuksen niin pitkälle, että hän haetutti itsensä "synnytykseen".*

‘The woman carried the joke so far that she **had** [s.o.] **take her** to “give birth”.’

([http://personal.inet.fi/taide/karjalainen/hullu\\_maailma.html](http://personal.inet.fi/taide/karjalainen/hullu_maailma.html), 13.1.2005)

(4b) *Älä hae, vaan haetuta (ole niin hyvä, että maine kantaa edelläsi: Ei koskaan tarvitse hakea töitä, vaan sinua pyydetään töihin. Säästyt karsealta cv:eiden ja hakemusten kirjoittelulta.!)*

‘Don’t apply – let them come to you (‘**get applied**’/make [s.o.] fetch) (be so good that your reputation precedes you: you don’t need to apply for a job – you will be headhunted. You will be spared the harshness of writing CVs and applications.’

(<http://www.tupla.com/boost/channels/default/vinkit/1015495627923/1015495634609.html>, 13.1.2005)

(5) *Nainen<sub>2</sub> haetutti<sub>1</sub> itsensä<sub>3</sub> synnytykse<sub>4en5</sub>*  
 woman fetch-caus-past-3sg self-acc-px3sg childbirth-ill  
 ‘The woman had [s.o.] take her to childbirth.’

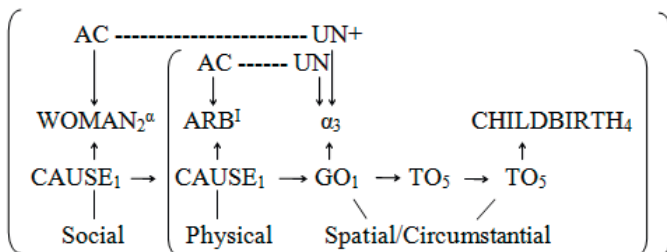

The conceptual structure as well as the syntactic behaviour of the verb *haetuttaa* change remarkably in the following examples. This is obviously due to the submeaning of the root verb *hakea*, which according to NS is ‘to try to get s.t. or s.o. out of sight or missing or necessary to come into view or disposal’. Consider example (6): *haetuttaa* here obtains the characteristics of a perception verb. The first causer is a non-human argument (‘cadmium tally’); the implicit SAR, the argument of the second causation, is an active participant but also an experiencer:

(6) *Nämä apatiitin kadmiumluvut<sub>2</sub> hieman haetuttivat<sub>1</sub>. Löytyvät Leipä Leveämmäksi- lehdestä toukokuulta 1991.*

‘The cadmium tally of apatite had [me] searching a bit. [It] turned up in an issue of *Leipä leveämmäksi* magazine from May 1991.’

(<http://chat.yle.fi/uutiset/ubb/Forum23/HTML/000001.html>, 13.1.2005)

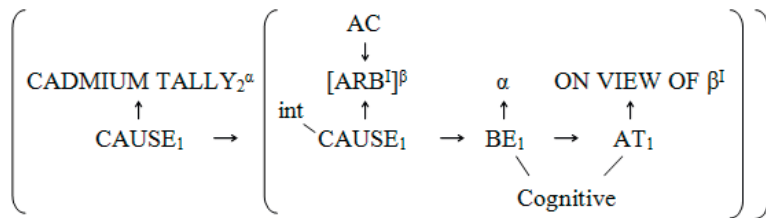

What exactly induces the activity of the SAR is that the argument of the first causation is missing, or more precisely temporally absent. The caused activity in (6) is observation and perception, a cognitive activity. The arbitrary implicit human participant is in a sense an ‘active experiencer’: in addition to experiencing the state of something being missing, the experiencer is also actively and intentionally searching for the missing object; the situation does not merely happen to it. For this reason, it is marked as an actor on the action tier. Note also that there is only one action tier present in (6), because the SAD does not actively dominate the SAR (or any other conceptual argument). Characteristic of the seeking process is the intentionality of the seeker (this feature distinguishes it from the verb *löytää* ‘to find’, where the activity of the finder is not intentional). The actor is actively striving to achieve the result; therefore, I add the feature *int* (intentionality) to the second CAUSE function in (6).

As the combination in (6) shows, the object of searching, assigned as the subject in syntax, is spread out in the conceptual structure. Also, the implicit SAR is bound to the location argument. Therefore, both causation arguments are combined with indexes; the argument of first causation (CADMIUM TALLY) is coindexed with the theme argument (bearing the index  $\alpha$ ) and the implicit SAR is coreferential with the recipient location ( $\beta$ ). The effect of the second causation is achievement of a state where the theme is within the view

of  $\beta$ . This location is understood as a kind of possession that is not spatial but rather perceptual. Therefore, I mark the semantic field of the location zone as ‘cognitive’. I leave the semantic fields of the causations in (6) open, since it is complicated to exactly define the background and effect of the causers.

The seeking process in (6) is restricted by the temporal adverb *hieman* ‘a little’. Temporal restrictors seem to be characteristic of this kind of expression. Consider examples (7a-c), where the temporal restrictors are *hiukan* ‘a little’, *melko pitkään* ‘a pretty long time’ and *parilla minuutilla* ‘in a couple of minutes’. The temporal modifiers alter the nature of causation in a way that the causation becomes successful i.e. completed (the sought-after object comes into the view of the SAR at the end-point of the time expression). Interestingly, temporal modifiers seem to add an epistemic modal nuance, an estimative shade, to the whole expression<sup>58</sup>. Note also that example (7b) is the only one with a syntactically expressed actor-SAR, the adessive adjunct (*minulla* [I-ade]). The arbitrary SAR typically refers to the speaker or can be understood in a generic sense. I have underlined the temporal modifiers in the examples below.

(7a) *Terveisiä kaikille, etenkin tutuille! Hiukan haetutti täsmälisen nimen puuttuessa ennenkuin löysin perille.*

‘Hello to everyone, especially to my friends! Without an exact name, I **had to look around** a little before I found my way here.’

(<http://www.oulunetelainen.net/saviselka/vieraskirja/>, 13.1.2005)

(7b) *Kyllä minä maksoin sen ihan nettipankin kautta. Se sivu kyllä **haetutti** minullakin!! melko pitkään mutta kyllä se siellä jossain on.*

‘Yes, I paid for it in the Internet bank. The page **had** [me] **looking** for a pretty long time, too, but it’s there somewhere.’

(<http://keskustelu.suomi24.fi>, 13.1.2005)

(7c) *Ratamestarin merkkauksista huolimatta tuli rastilippujen viejälle yhden lipun valitettava unohdus, joka paikattiin ensi viestien tultua maalille. Puute **haetutti** vähintään parilla minuutilla, joitakin enemmänkin.*

‘Despite the markings of the track master, the control point flag carrier experienced an unfortunate lapse of memory that was fixed when the first relays were at the goal. Its absence **kept** [us] **looking** for at least a couple of minutes, some people even more.’

(<http://www.paimionrasti.fi/peimari/00/tulokset/030800.html>, 13.1.2005)

The significance of temporal modifiers in the nature of causation can be detected in comparison to the next *haetuttaa* examples. Examples (8a-b) are analogous to the previous perception expressions, with the difference being

<sup>58</sup> I would like to thank Ilona Trigel for drawing my attention to this.

that the situation is now atelic. Instead of temporal restrictors, the reflexive anaphora *itseään* ‘itself’ is used. The aspect changes: the process is not restricted by explicit temporal modifiers, the goal of the activity is not reached, no accomplishment happens and a new situation does not come about. Similar to structure (6), the SAD is both the causer and the location argument. Note the hypothetical nature of the cause of the search in (8a); the camping area is not there before the search, and the intention is to see if it can be found.

(8a) *Telttapaikka haetuttaa itseään, sellaista ei löydy parinsadan metrin säteellä nuotiopaikasta.*

‘The camping area **gets you looking** for it – there’s no such thing within a radius of a couple hundred meters.’

(<http://kotisivu.mtv3.fi/juhopea/130602.html>, 13.1.2005)

(8b) *Esimerkiksi paikannimi Tshernobyl haetutti itseään turhaan "toisen kotimaisen" sanakirjoista, koska se on ukrainaa, tarkoittaen – apokalyptisesti - katkeraa koiruohoa.*

‘For example, the name ‘Tshernobyl’ **had** [me] **looking** for it in vain in the ‘second national language’ dictionary, because it is in Ukrainian, and means, apocalyptically, bitter absinth.’

(<http://guns.connect.fi/gow/ruutiset2.html>, 13.1.2005)

In these examples, the meaning is still ‘to strive to catch sight of something, to get something to appear, to seek’, with the difference being that the seeking process does not have any effect. Jackendoff (1990: 130-133) divides the notion of causation according to how successful it is by using the following ‘success parameters’:  $CS^+$  represents an application of force with a successful outcome;  $CS^u$  encodes an undetermined outcome of force; and  $CS^-$  a failed outcome of the application of force. Nikanne (2006: 233-234) distinguishes the characteristics of the successful activity further with the features [goal] and [bound], so that  $CS^+$  is an f3 with the features [goal] and [bound]; and  $CS^-$  encodes an f3 with [goal] and the absence of the [bound] feature, formalized as [ $CS^+$  [gl, b]]; [ $CS^-$  [gl]]. Success parameter functions appear to be useful in the analysis of *haetuttaa*. Consider the LCS of example (8a) in (9). The first causation in this combination is successful, while the second causation has no successful outcome. Since the whole situation denoted by a sentence is complete if bound everywhere in the conceptual structure that it can be (see Nikanne 2006), situation (9) is not complete.

- (9) *Telttapaikka<sub>2</sub> haetuttaa<sub>1</sub> itseään<sub>3</sub>*  
 Tent.space fetch-caus-3sg self-part-px3sg  
 ‘The camping area<sub>2</sub> gets you looking<sub>1</sub> for it<sub>3</sub>.’

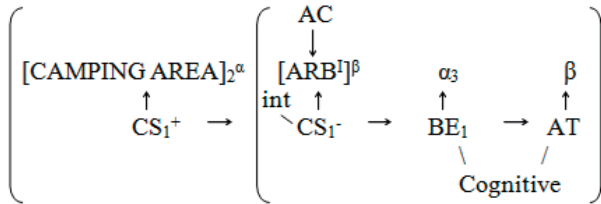

It is notable that the verb pair *haettaa* [fetch-caus] and *haetuttaa* [fetch-caus-caus] does not behave similarly in terms of cognitive possession structures (6) and (9): the shift to a perception verb seems to happen only to *haetuttaa*, or at least I have not found analogical examples with *haettaa*. However, another CSD, *etsityttää* ‘make s.o. find, seek, look’ adapts exactly the same pattern of perception: compare the examples with *etsityttää* in (10a-c). Also, here the double-*ttA* derivative variant from *etsittää/etsityttää* seems to ‘specialise’ in this particular meaning. The NS explains the root verb *etsiä* ‘to look, search’ using *koettaa löytää*, *hakea* ‘to try to find, fetch’. Consider examples (10a-c) with the verb *etsityttää*. These examples include temporal restrictors, encoding a telic situation. Example (10c) is exceptional in the sense that in addition to the temporal modifier (*pitkään* ‘for a long time’), it also includes a reflexive anaphora (*itseään* ‘itself’).

- (10a) *etsityttää* [seek-caus-caus] ‘make s.o. find, seek, look’

*Sitten olikin taas jonkin aikaa helpompaa, mutta hieman etsitytti.*  
 ‘Then it was easier for a time, but [I] **was made to look a bit.**’  
 ([http://www.sportwings.org/karin\\_lennot.htm](http://www.sportwings.org/karin_lennot.htm), 13.2.2005)

- (10b) *Sitä tehdessäni versio etsitytti jonkin aikaa.*

‘While doing this, the version **had** [me] **looking** for it for some time.’  
 (<http://gamma.nic.fi/~juhatik/ruohonpai.htm>, 13.2.2005)

- (10c) *Pian tämän jälkeen yhdestä peräkärystä pudonnut vararengas etsitytti itseään pitkään.*

‘A spare tire that had been fallen off the trailer soon after that **had** [us] **looking** for it for a long time.’  
 (<http://www.allroadtour.fi/kairi99/kuvat/kuva60.htm>, 13.2.2005)

In the examples above, the verbs *haetuttaa* and *etsityttää* express a conscious and goal-oriented attempt to find the missing object. Vilkuna (1992: 93) compares the intentionality component of verbs like ‘to promise’, ‘to wait’

and ‘to plan’ with modal expressions including a futuristic and hypothetical component. She analyses the verb *etsiä* ‘to seek’ using the phrase *yrittää löytää* ‘to try to find’ and suggests that the finding event is detached in respect of the trying temporal point to the future. The futuristic-hypothetical sense is also present in the case of the verbs *haetuttaa* and *etsityttää* if the semantic field of the transition of the theme is cognitive.

What is the consequence of the different readings of *haetuttaa* presented above for its lexical entry? Are there two entries, one for the spatial and other for the perception verb variant (the latter applying both the successful and unsuccessful causation constructions)? Should the indexing variations be reflected in the lexical entry? The alternations presented above clearly affect the argument structure. Should they be encoded as the lexical information of this verb? I describe the spatial transition of theme reading and the cognitive state of the argument coindexed with the SAD sense of the verb *haetuttaa* in (11a-b). In order to encode the alternation in the argument binding (in (11a)) and the successfulness of the causation (in (11b)), I adopt the abbreviating convention used in Jackendoff (1985, 1990): the curled brackets { } in the LCS mark that the position is mutually exclusive in relation to the different positions. This notation enables us to unify the alternations of the argument structure. In principle, the curled brackets here can be argued to indicate two different structures, but as they are quite closely related, it is convenient to mark the alternative connections in this way. Note that structure (11a) is valid for both *haetuttaa* and *haetuttaa*; the analysis in (11b) describes only the behaviour of *haetuttaa* (and also *etsityttää* ‘make s.o. find/look’).

(11a)

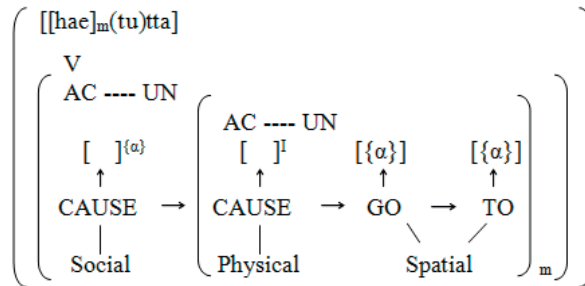



(11b)

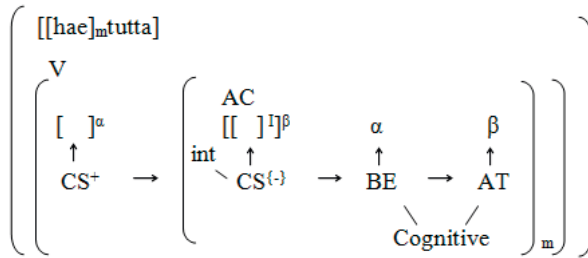

I have not included one of the deictic aspects of *hakea* ‘to fetch’ in (11a) i.e. the notion of the fetched object being in a place before transferring to another. Note also that the action tier configurations differ in (11a) and (11b); (11a) has two act-chains, while (11b) has only the actor of the root verb structure assigned. The parallel causative derivative of *haetuttaa*, *haettaa*, only adapts the lexical entry (11a). Thus, these derivatives are not completely identical: they share information on one lexical entry but not the other. The case of *haetuttaa/haettaa* reflects the derivative system and language in general; the submeanings of the root verb may develop in different directions in the derivation. The assumption of the identity of *haettaa* and *haetuttaa* is thus not completely correct: they share some characteristics, but not all. The function of the simple *ttA*-morpheme and the compound *ttA-UttA* is not fully equal; they can specialize to express different submeanings of the root verb.

When it comes to structure (11b), we can ask if the verbs *haetuttaa* and *etsityttää* are synonyms regarding this meaning. Another possible explanation of the readings of *haetuttaa* is that the structure in (11b) is a constructional pattern, since it licenses the different verbs (*haetuttaa* and *etsityttää*) to behave in a similar way. An argument for the construction theory was discussed in section 4.5 in connection with the argument structure variations of *leikittää* ‘make s.o. play’. The exceptional direct argument-linking in relation to the morpholexical level occurring in connection with the verb *leikittää* is also visible in structure (11b). Consider the morphorole and DA-linking of example (8) in (12). As we can see, the OAR assigns the DA1 position, which contradicts the argument linking system of the CSDs as stated in (6) and (11) in section 3.2, assuming that the DA1 position is reserved for the SAD only. Another distinctive feature of this structure is that the SAR is not expressed; the arbitrary actor in this construction must be reasoned from context. These features indicate that the configuration in (12) is a structure-specific linking rule, pointing out the direction we must take with the construction here. We can identify the pattern occurring with the verbs *haetuttaa* and *etsityttää* as the ‘Perceptual Causative Construction’.

- (12) *Telttapaikka<sub>2</sub> haetuttaa<sub>1</sub> itseään<sub>3</sub>*  
 Tent.space fetch-caus-3sg self-part-px3sg  
 ‘[The camping area]<sub>2</sub> [gets you looking]<sub>1</sub> for it<sub>3</sub>.’

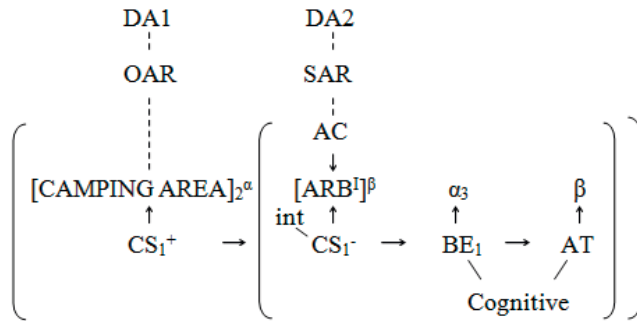

- (13) Perceptual Causative Construction

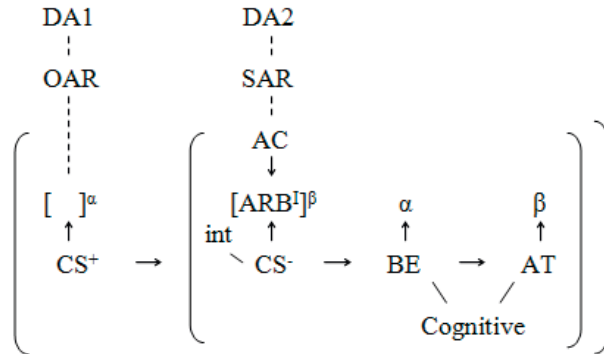

## 5.4 Discussion of CSD constructions

Following the analysis of the constructional patterns of CSDs, it is worth reviewing general outcomes in this chapter. Regarding the notion of construction, an important question is how a CSD construction differs from regular CSDs i.e. what is the interface of construction-specific rules with productive lexical principles? Which linguistic levels do these constructions involve? What are the ensuing categories like in terms of stable and variable features? Do the constructional categories overlap? These questions lead us to the methodological effects of the results of the analysis.

In this chapter I attempt to outline the constructional patterns through conceptual structure analysis of CSDs and to schematize exceptional mapping relations. This study is not an exhaustive account of all idiomatic and idiosyncratic phenomena occurring in connection with CSDs. The

analysis concerns only a few (but in my opinion representative) derivatives for the present purposes, highlighting some of the idiosyncratic phenomena of these diverse verbs and indicating that there are further phenomena related to causatives derived with the *ttA*-morpheme than traditional curatives and also emotive causatives. Another aim of the constructional study in this chapter is to unite the formal description and observations from concrete language material. Thus, the formal generalizations made are mediated using a bottom-up approach striving to include the interactional effects on the analysis.

An assumption shared by the construction grammar theory and the approaches studying the lexicosemantic rules behind the ability of verbs to occur in syntactic frames (for instance Fillmore (1982 & 1984), Goldberg 1995, Pinker 1989 and Levin 1993) is that the altered arrangements of syntactic complements must be reflected in the different semantic representations of the main verb. The analysis in this chapter explores the phenomenon in which the verb sense is modified not as a result of the change in the syntactic realization and argument linking to the morphoroles, but by various semantic aspects. Compare the sentences in (1-3) with the same morphosyntactic form of (NP<sub>subj</sub> + V<sub>CAUS</sub> + NP<sub>partobj</sub>), all applying the basic transitive sentence structure and the unbound situation type. However, sentence (1) encodes neutral (prototypical) participation dominance, (2) denotes power abuse and (3) responsibility removal from the single actor. The representative CSDs are *laulattaa* ‘make s.o. sing’, *kyykyttää* ‘make s.o. squat’ and *syötättää* ‘make s.o. eat’:

- (1) *Matti laulattaa Pekkaa*  
 Matti sing-caus-pres-3sg Pekka-part  
 ‘Matti makes Pekka sing.’
- (2) *Matti kyykyttää Pekkaa*  
 Matti squat-caus-pres-3sg Pekka-part  
 ‘Matti bosses Pekka around.’
- (3) *Pettymys syötättää Pekkaa*  
 disappointment eat-caus-pres-3sg Pekka-part  
 ‘Pekka’s (over)eating is due to disappointment.’

When uniting the syntactic and conceptual structures of sentences (1-3), the result can be illustrated as in (4). The angled brackets in this analysis indicate optionality, and the curled brackets mutual exclusivity. The conceptual structure in (4) allows us to infer the stable and variable features of these structures. Besides the syntactic structure and morphorole linking (in all three cases, the NP indexed with *k* is linked to the SAD and the NP indexed with *n* is linked to the SAR), the stable elements are hence the thematic function

‘cause’ followed by a zone 2 function (possibly also a zone 1 function) and the double-rolled SAR on the action tier level. Note that the quality of the undergoer (UN) can switch to the malefactive (UN-). The crucial differences occur on the conceptual structure level, concerning the nuances of the action tier, the semantic field type and the semantic features. In relation to the prototype structure (PT2.2) represented by the conceptual structure of sentence (1), the other propositions in (2) and (3) include elements in addition to the prototypical properties, such as the feature -ctr or another type of category (semantic fields). A component can also have a different variant (UN- instead of UN) or it can completely miss a node, like the AC-role of the SAD in the conceptual structure of sentence (3).

(4) Syntactic and conceptual structures of (1-3)

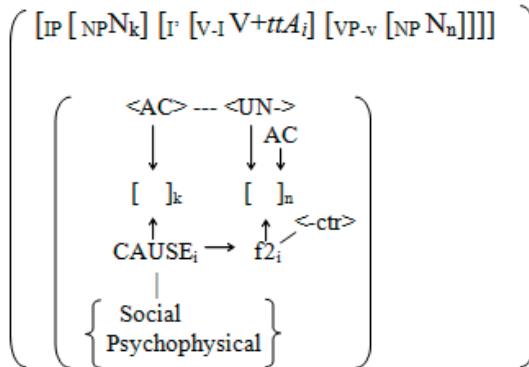

The aspects important to the social conceptualisation and power relationship are closely connected to the participants in the situation and their relationship expressed in the linguistic utterance. The relevant properties of the people involved in a **power misuse event** (expressed by sentence (2)) are the following: the SAD controls the activity of the SAR and misuses its power position in respect of the SAR (at least from the speaker’s perspective). The SAR is an active theme whose activity is humiliating and often done in vain. The lexicalised negative dominance is the crucial characteristics of the Power Misuse Construction. The syntax of the Responsibility Shift Construction is identical to the PMC, but the SAR here is not acting under an active SAD’s dominance. The essential property of the **responsibility removal event** (see sentence (3)) is the control shift from the active SAR to the non-active SAD. The changed cognitive background of the causation in this case is expressed by the psychophysical semantic field. For these constructions, the properties of the SAR are thus central. The SAR features and action tier roles of sentences (1-3) are bunched together in (5):

- (5) *Matti laulattaa Pekkaa* [SAR<sub>n</sub> (UN, AC)]  
*Matti kyykyttää Pekkaa* [SAR<sub>n</sub> (UN-, AC)]  
*Pettymys syöttää Pekkaa* [SAR<sub>n</sub> (UN-, AC (-ctr))]

The examples above show that the correspondence between syntax and semantics is not a one-to-one relationship; semantic idiosyncrasy cannot be inferred directly from the syntactic structure. What then is behind the different readings of these sentences? I argue that changes in conceptual structure, triggered by contextual and interactional information, can lead to the constructional patterns. I have called these patterns ‘interpretation constructions’ with the indication that there are sets of interpretational templates stored for certain situations. In other words, this suggests that there are pragmatic interpretation patterns available to language users to be applied in appropriate social situations. The interpretation constructions show how the attitudes that occur in communicative situations lexicalize and what kinds of structural networks trigger these constructions. This is a description of the pragmatic information these verbs convey. Since the term ‘interpretation construction’ is anchored in the reciprocal nature of interaction, it involves the speaker’s intention, on the one hand, and the process behind the understanding of the hearer, on the other. I will return to the issues related to the intentional aspects of the interpretation constructions in the next section, and focus here on the recipient’s perspective.

How does an interpretation construction work in the reasoning process? From the recipient’s point of view, there are several possible interpretation options available in the comprehension procedure. I assume that the comprehension of an interpretation construction is based on different contextual inferences from which the recipient chooses the appropriate option. This assumption is in line with the relevance theory (Sperber & Wilson 1986)<sup>59</sup> that considers the contextual effect necessary in a description of comprehension effect. According to this theory, the interpretation of an utterance involves contrasting the contextual effects with the part already understood i.e. working out an outcome on the basis of assumptions retrieved and processed in interaction and forming a gradually changing background to new information processing (ibid. 118). In the case of the Power Misuse Construction, at least two readings are available: the literal (for instance spatial, if the root verb is a motion verb) and the power abuse sense. I assume that the first reading corresponds to the prototype CSD structure. A slightly different case is, for instance, the verb *syöttää* ‘make s.o. eat’ when used in the Responsibility Shift Construction. This construction erases some of the meaning components of the root verb *syödä* ‘to eat’, for instance the

---

<sup>59</sup>The relevance theory elaborates the Gricean maxim of relevance (Grice 1975), investigating the mechanisms behind the optimal relevance of an utterance and pragmatic inference of meaning. The maxim of relevance states: Be relevant i.e. say things related to the current topic of the conversation.

nourishing or social sides of eating. In the responsibility removal setting, *syötättää* focuses on the negative aspect of eating: the consequences accompanying surfeit.

Basically, the constructions discussed in this chapter are twofold in nature: one type is the interpretation construction with an implicative connection to interaction (the PMC and the RSC); and the other type is based on a particular linking configuration (the responsible SAR construction or the Perceptual Causative Construction in connection with *haetuttaa* ‘make s.o. fetch’ and *etsityttää* ‘make s.o. seek’). Both kinds of patterns are revealed through their conceptual structure, or more precisely by contrasting their conceptual structure with the prototype CSD templates; it is in relation to the prototypes that the idiosyncrasy appears. Syntactically, certain tendencies can be seen in, for example, object marking: competition situations tend to express the SAR as an accusative object, while in a typical power abuse or responsibility shift situation the SAR is in the partitive. Object marking is, however, a matter of aspect, with a certain influence on the reading of these constructions.

The lexically determined verbs in this study are *tapattaa* ‘make s.o. kill’ in section 5.3.3 and *haetuttaa* ‘make s.o. fetch’ in section 5.3.4, which can be seen as special cases. The ‘look of reproach’ in connection with *tapattaa* can also be seen as an interpretative pattern connected to the social dimension, while the causative-locative adjunct signals a morphosyntactic idiosyncrasy. The perception variant of *haetuttaa* expresses no direct social dominance, but it is an interesting case in several respects. It is related to questions about lexical information-encoding, implying that the root verb characteristic may affect the derivative variants in a distributive way when actualizing the submeanings between different causative forms. This leads us to some fundamental issues about the nature of language. The verb pair *haetuttaa* [fetch-caus-caus] and *haettaa* [fetch-caus] indicate that the recursive forms are not completely synonymous; instead, the number of causative morphemes added to a verb may indicate function distribution: the submeanings of the root verb may be divided between derivative variants. We saw a division between functions between *haettaa* as a spatial transition of the theme and *haetuttaa* additionally as a transition on a cognitive level. Also, the double-*ttA* variants *syötättää* [eat-caus-caus] and *juotattaa* [drink-caus-caus] showed a tendency to specialize in responsibility shift denotation (see section 5.3.1). In contrast, a verb with an open or unspecified theme like *teettää* ‘make s.o. do’ adapts several idiosyncratic patterns (see section 5.3.2). It is apparent that compared to verbs with specific semantic content and restricted denotation (like *naulauttaa* ‘make s.o. hammer/nail’), *teettää* allows the actual activity to be left open or to be implied on a contextual basis.

The notion of construction in this study thus interfaces with the construction grammar requirement on a constructional pattern to wield resources specifying lexical, semantic and pragmatic (rather than just

syntactic) information. The constructions discussed here display idiomatic semantic and pragmatic behaviour in terms of what could be considered the same morphosyntactic units regarding their parts, according to Fillmore, Kay & O'Connor's definition (1988). The approach of my study diverges in that the lexical units are not considered as constructions themselves but as representatives of an independent module of language which is part of complex linking relations. The analysis of CSDs can be seen as an examination of the conceptual semantics assumption (see Nikanne 2005) that constructional patterns appear in the background of the more systematic rules of a language.

How does conceptual semantics methodology cope with the description of constructional phenomena? It has been proven to provide an instrument to describe the complex relational configurations and to enable us to explicate the relevant parts of these kinds of constructions. The main difference of the Tiernet model compared to other compositional analyses is that the micromodular approach does not consist of lists of attributes with certain values or constituent (mother-daughter) relationships, but these elements are seen in a network of features, functions and semantic fields and the connections between nodes. The features used to define the constructions are clear-cut by nature; they are either binary or privative. This enables us to explore the complex relations between the different levels and nodes with their mutual connections. At the same time, conceptual semantics methodology does not exclude the prototypical phenomena of language; it can be used to reveal lexical variations or the alterations within constructional patterns, when the goal is to explicate the variations or grades of a continuum. In order to take into account the effect of resemblance on word formation, we need a theory on which to base the definitions and stipulations (conditions); in other words, compositional analysis.

What is the status of CSD prototypes in relation to CSD constructions? Since the prototype structure represents a conceptual template of features common to CSDs, a difference is that the prototypes are not seen to be *independent* of lexical items but rather as shared lexical information. The general expectation can be said to be that a new deverbal *ttA*-derivative will correspond to one of the prototype structures. Also, CSD constructions basically adapt the prototype structure, with some idiosyncratic aspects added to it. Therefore, the prototypes can be seen as default cases; as the productive rule. CSDs thus represent more general rules in that they take the prototype structure, and at the same time also form particular patterns. In principle, we can ask how the constructional patterns differ from the regular ones – in order to build a causative construction, it must be applicable to more than one verb. A crucial difference is that not all CSDs are able to apply the constructions discussed in this chapter. There is a tendency for CSDs with certain semantic properties to be exposed to the constructions (for instance

CSDs derived from roots expressing self-agentive motion are exposed to the PMC).

Do the prototype templates and constructional patterns as analysed in this study function as a basis for analogical relationships between single verbs? In Itkonen's (2005: 1) definition, the analogy is based on structural and functional similarity between two systems, presuming the same number of parts of these systems and a metarelation between the system-internal relations. The analyses of single verbs and constructions in this study are comparable to the prototype templates. When a verb is adjusted to fit a construction, its conceptual structure shows similar structural relationships to the constructional structure. There thus exists a close relationship between these structures; moreover, the prototypes can be seen to be representing the analogous features. Hence prototype templates do not violate the idea of analogy – they can be seen to function as analogical patterns for the default cases of CSDs. Also, constructional patterns function as analogies for verbs applying the respective constructions, but with more precise restrictions on the root verb.

When going into more detail with conceptual structure analysis regarding the constructions discussed in this chapter, an important category regarding social conceptualization is the action tier. Variations in action tier configuration have proven to be a crucial aspect in the description of constructional patterns related to CSD verbs. A problem in defining action tier roles is that the activity is not a straightforward matter. For instance, the responsible SAR construction does not necessarily specify what exactly the actor is doing (*Konferenssi teettää töitä* 'The conference gets us working') or who the actor refers to. The occurrence of activity is still emphasized by the construction, and the arbitrary SAR is specified as the actor.

The semantic fields bear significant information regarding constructional patterns. An outcome of the verb analyses in this chapter is related to the expansion of verb semantics to various cognitive areas as a result of extended use in different contexts. This phenomenon raises the question of defining the semantic field of causation. In several cases it is difficult to determine the nature of causation and how exactly the causing event affects the activity of the SAR. What is the status of semantic fields in this light? A possible implication of these problems could be that the cognitive background of causation may be seen as neutral in respect of the semantic fields, with the consequence that the semantic fields in zone 3 may be treated as optional.

Another possibility is to further define distinctive fields of causation. The social semantic field appears to be a broad area that can be divided into several subfields; the constructions discussed above suggest that there are various situational types of causativity. Based on the examination in this chapter, I suggest differentiating between the semantic fields as social, competition, psychophysical and psychosocial. Additionally, the semantic fields of the core zones were supplied by the cognitive semantic field, as



suggested in connection with perception verbs (as *etsityttää* and *haetuttaa* in the meaning ‘make s.o. seek’). These fields are related to human behaviour, reflecting different aspects of it. Psychophysical causation refers to a mental-physiological influence (as in *Pettymys syötättää minua* ‘Disappointment makes me eat’), comprising social pressure, desires, fears and psychological states (see 5.3.1). The psychosocial field describes a social event, discourse or social norms affecting human behaviour (*Konferenssi teettää töitä* ‘The conference gets us working’, see 5.3.2). Social causation is reserved for human interaction; it is the semantic field of prototype CSD situations. As a condition for social communication, the causer and the performer of the caused event should be human (as in ‘X rushes Y into doing something’ and ‘X spurs on Y’). The competition field discussed in 5.2.4.1 is related to competitive situations creating a special environment between the opposing participants. Grouping the semantics fields related to social causation, competition stands near the social field, typically involving two human participants; the difference is that both actors are participating in the competition event, striving to achieve the same goal, and the causation is not indirect as in social causation. The competition situation is a human way of perceiving the world (for instance, plants do not compete, even though their dispersion may be seen as a competitive process). The arrangement of semantic fields related to social causation can be visualised as a network; see (6):

(6) Semantic fields of social causation

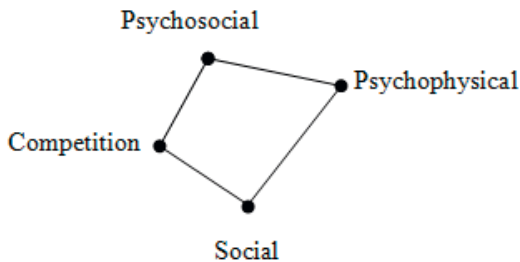

The obvious question that arises is what the exact restrictions between these domains are and whether the fields overlap or exclude one another. Note that for instance an emotional state may include social nuances (‘X irritates Y’). I leave matters related to the semantic fields for future research; the verb analysis in this study has highlighted the need for further examination of these phenomena.

The third central area of constructional patterns is semantic features, especially attributes related to agent features. Properties like control, volition and consciousness are nuances related to human social relations. How justified are the features used in the analysis of constructions? Analysis

indicated that the semantic features are related to the concept of responsibility. Are these features reduced to each other, and if so, to what degree? What is their function in CSD constructions? Responsibility-related phenomena seem to be divided between different domains within the conceptual structure. The semantic features are needed, for instance, when the action tier and thematic tier do not reflect the conceptual structure in question, as in connection with the Responsibility Shift Construction. The argument structure of the construction, the semantic features connected to the human arguments, the nature of causation and the question of participation in the activity are essential aspects when studying the notion of social causation.

As the interpretation constructions discussed in this chapter indicated, the aspects related to the responsible actor move in the ‘twilight zone’ between semantics and pragmatics. The Responsibility Shift Construction reflects the social nature of the notion of responsibility, described in expressions related to defence, calumny and blame. The attempt to relieve the actual actor of accountability by blaming an outside factor can be seen as motivated by self-defence: the need to save face. Also, the disapproval effect in connection with the Power Misuse Construction is based on blame. The notions of guilt and responsibility seem to be associated, in the sense that there is no guilt without responsibility. The accusation is based on the attempt to hold the person (or phenomenon, as in the RSC) to blame to account; if there is somebody to blame, this person can also be held responsible for an occurrence. Via responsibility and the look of reproach, the interactional aspects are linked to the semantics of an expression.

The issues related to responsibility lead us to the broader question of the primitives of social representation. Is there a separate domain of social relations? The constructions discussed so far are complex patterns including fixed mappings to combinatorial modules (morphology and lexicon) as well as to tiers belonging to syntactic and conceptual structures. In some cases, the CSD constructions discussed have the same syntax but differ in semantics and may include particular pragmatic information. Recall the outline concerning the representations of Finnish grammar forming the basis in Nikanne (2002 & 2006) (see Figure 3 in section 2.2.3), including the results of constructional analysis in this chapter in Figure 5:

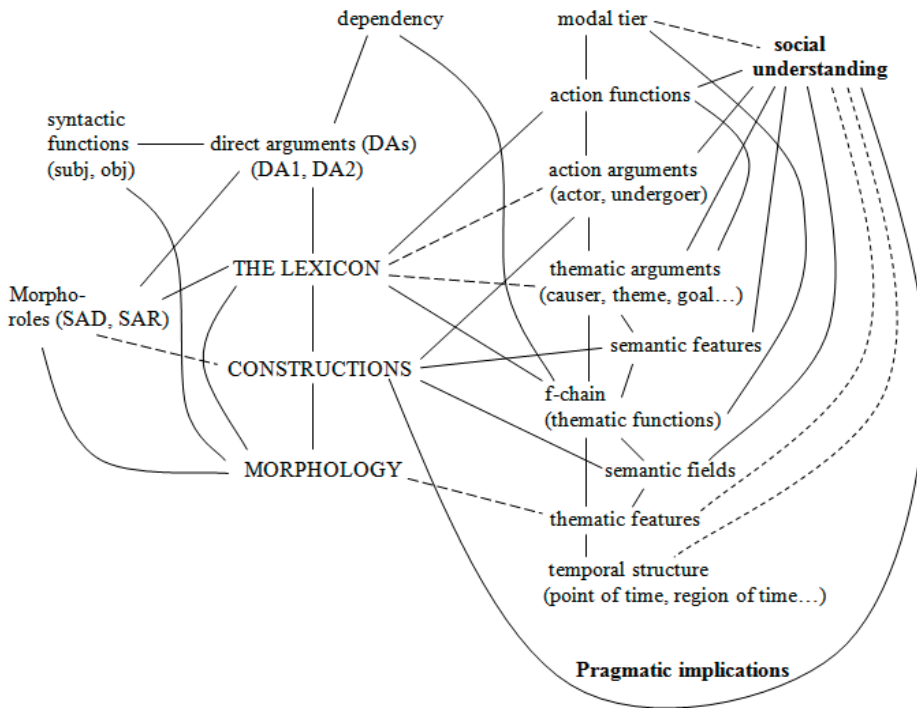

Figure 5. Modules relevant to study of the social dimension in Finnish

I thus argue that the aspects involved in the concept of ‘social understanding’ in Finnish are divided between the different micromodules of the conceptual structure<sup>60</sup>. As discussion of the constructions of social dominance has shown, these verbs display complex mapping configurations of different kinds of information. The outline in Figure 5 does not exclude the possibility that the nature of social relations is specified in the lexicon. In addition, constructions may have direct links to fragments connected to the social dimension. For instance, the Responsibility Shift Construction is directly linked to the semantic features module via the -ctr feature, and the Power Misuse Construction has a particular mapping to the action tier roles module by assigning the malefactive SAR. Furthermore, interpretation constructions mediate links to interaction and contextual reasoning; therefore, a line marking pragmatic implications between the social understanding module and constructions has been added to the outline in Figure 5.

<sup>60</sup>The connection of social dimensions and the modal tier is not the topic of this study, with the exception of *haetuttaa* in the meaning of ‘make s.o. search’, which touched on epistemic modal features. Deontic modality seems to be closely connected to social dimensions (‘You cannot do this!’ ‘She must go.’); I leave this topic for future studies, and mark the link between the modal tier and social domain using a dashed line.

#### 5.4.1 Constructions and the salient properties of CSDs

What can be seen as the lexical information of a CSD? Should the constructional uses of a CSD be encoded in its lexical entry? The examination of different verbs above indicates that CSDs are able to behave quite flexible regarding their participation in different constructions. I suggest that by defining the constructions and prototype templates we can produce a network-like relational system which describes dynamics in language in a different way than the enumerating classification of verbs. The prototype and construction templates function as a word-grouping centre, enabling us to see the interaction between CSD constructions. Are some of the constructions or verbs ‘better’ examples and some ‘marginal’? In this section I discuss the relationship between constructions and verbs, and the combining of verbs with different constructions. I argue that CSD constructions can be seen as patterns attracting verbs into a cluster. I will also discuss other trends that can be seen in my material.

What then is salient conceptual information common to CSD verbs? Since these verbs involve one or more causations, and subsequently also one or more caused events in the CS of these verbs, the properties of the SAR are crucial. An active SAR is the ‘reason’ for the existence of two action tiers, bringing about a more complex dominance relationship than in a one-tiered configuration through its ability to assign two different action tier roles. It represents a ‘two-sided force relationship’ – the force directed *at* it (from left to right in the thematic tier) and further *from* it. CSD constructions seem to drag verbs with similar morpholexical properties in to adhere in a cluster; at least some aspects of the derivative should match the pattern. A common feature of both PMC and RSC verbs is that they are often verbs whose root verbs encode some kind of (spatial) activity performed through one’s own force, typically encoding self-agentive processes. Additionally, the constructional patterns are influenced by the semantic fields and semantic features. The perception causatives construction discussed in connection with *haetuttaa* ‘make s.o. fetch’ presupposes a root verb with certain lexical characteristics: the semantic field in the core zones must be convertible to the cognitive field, and the theme argument must act intentionally.

There are different ways for a verb to become part of the construction, just as the lexical properties of a verb vary. The two verbs adapting the Power Misuse Construction analysed in more detail in this chapter, *juoksuttaa* ‘make s.o. run’ and *kyykyttää* ‘make s.o. squat’, explicate the dynamics. According to the observations based on my material, the verb *kyykyttää* occurs mainly in the PMC (see 5.2.4.2). This verb is exceptional in that it hardly ever seems to appear in its compositional meaning i.e. neutrally in respect to the power abuse implication. Compared to *juoksuttaa*, we saw in section 5.2.1 that this verb has several submeanings. The verb *kyykyttää* can thus be seen as a better example of a PMC verb than *juoksuttaa*. *Kyykyttää* also demonstrates a special lexical development: the metaphorization process

can be argued to have taken place before derivation, as this verb is strongly associated with the idiomatic expression *köyhät kyykkyy* ‘the poor into a squat’. However, the possible (compositional) secondary meanings of a PMC verb are ruled out by contextual clues and an attitudinal stance connected to the proposition. The activity itself extends from the spatial information encoded by the root verb towards more general and abstract, often context-dependent activity. Consider the examples of *juoksuttaa* in (1) and (2), where the actual activity denoted by the verb is driving a car (1) or carrying food to a table (2).

- (1) *Autoton ystävä juoksuttaa jatkuvasti jossakin ja kuvittelee että pienet bensakulut sinne tänne ei meidän taloutta kaada. Jotenkin ärsyttää yli kaiken kun ei saisi muka ajatella kustannuksia mutta kyllähän se ei enää kympeissä se hinta mene, jos ajaa kolmen kaupungin välillä erilaisten mielihalujujen perässä.*

‘A carless friend of mine **has** [me] constantly **running** around and imagines that low gas prices here and there do not destroy our economy. For some reason I’m extremely annoyed that we supposedly shouldn’t think about the cost, but you can’t count the price in tenners when you’re driving between three cities after one thing and another.’

([http://www.vauva.fi/keskustelut?p\\_p\\_id=forum\\_WAR\\_perhe&p\\_p\\_action=1&p\\_p\\_state=normal&p\\_p\\_mode=view&p\\_p\\_col\\_id=olum1&p\\_p\\_col\\_count=2&forum\\_WAR\\_perhe\\_action=viewThread&forum\\_WAR\\_perhe\\_forumThreadId=116374](http://www.vauva.fi/keskustelut?p_p_id=forum_WAR_perhe&p_p_action=1&p_p_state=normal&p_p_mode=view&p_p_col_id=olum1&p_p_col_count=2&forum_WAR_perhe_action=viewThread&forum_WAR_perhe_forumThreadId=116374), 16.12.2008)

- (2) *Meillä lapset syövät loistavasti, kunhan siihen syömiseen ei aseteta ennakkopaineita. /-/ Jos aikuinen juoksee, niin nenän edessä pitäisi olla kaakaota, leipää, teetä, maitoa, mehua, banaani, lihapiirakka ja jogurtti. (tämän kattauksen olen nähnyt omin silmin!) Mihinkään niistä ei tietenkään kosketa, kunhan juoksutetaan aikuisia, joiden omat ruoat jää syömättä.*

‘At our place, our kids eat really well, as long as there’s no pressure placed on them to eat beforehand. If parents are running around (willing to run around), cocoa, bread, tea, milk, juice, bananas, meat pies, yoghurt – everything is stuck under your kids’ noses. (I’ve seen this with my own eyes!) None of them are touched, of course, but the parents **are run around**, and their own food goes uneaten.’

(<http://www.eroperhe.net/keskustelu/index.php?topic=41210.msg594834>, 16.12.2008)

The competition verbs discussed in section 5.2.4.1 related to the PMC explicate how analogical pattern functions and verbs undergoing different derivative processes (both denominal and deverbal *ttA*-verbs, but even opaque derivatives like *höykyttää*) adapt the model. Thus, regardless of the

route of formation, the results of derivation can be associated with the construction. I have divided at least the following derivatives as verbs adapting the Power Misuse Construction, defeat construction and destruction construction in Table 4. Note that some verbs (*kyykyttää*, *kynittää* and *pyörittää*) appear freely in two groups; these verbs adapt both the humiliation and defeat constructions (the division in Table 4 does not exclude other verbs crossing borders, since in appropriate contexts other verbs may join the PMC family). The PMC construction family was also discussed in section 5.2.5.

Table 4. Verbs in PMC family

<b>Humiliation</b>	<b>Defeat</b>	<b>Destruction</b>
Power struggle/vanity	Losing is embarrassing	Total destruction
<i>juoksuttaa</i> (> juosta ‘run’) <i>tanssittaa</i> (> tanssia ‘dance’) <i>ryömittää</i> (> ryömiä ‘crawl’) <i>pyörittää</i> (> pyöriä ‘spin’) <i>kierittää</i> (> kieriä ‘roll’) <i>hyppyyttää</i> (> hyppy ‘jump’) <i>kyykyttää</i> (> kyykky ‘squat’) <i>kyykytellä</i> (> kyykyttää) <i>pompottaa</i> (pomppia ‘bounce’) <i>pallottaa</i> (> pallo ‘ball’) <i>penkittää</i> (> penkki ‘bench’) <i>nakittaa</i> (> nakki ‘frank’) <i>nukettaa</i> (> Engl. ‘nuke’) <i>kynittää</i> (> kyniä ‘pluck’) <i>poistuttaa</i> (>poistua ‘move off’)	<i>kyykyttää</i> (>kyykky ‘squat’) <i>kynittää</i> (> kyniä ‘pluck’) <i>pyörittää</i> (> pyöriä ‘spin’) <i>rökittää</i> <i>kampittaa</i> (> kampi ‘crank’) <i>nokittaa</i> (> nokkia ‘peck’) <i>kepittää</i> (> keppi ‘stick’) <i>höykyttää</i> (?)	<i>nukettaa</i> (> Engl. ‘nuke’)

Croft (1998:73) argues that verbs cannot be strictly divided into semantic classes on the basis of the grammatical constructions in which they occur, because the grammatical constructions themselves convey a conceptualisation of the event. The weak and strong subconstructions of the PMC show that construction based on semantic particularities also expresses different event types, in this case processes involving change and no change respectively. The defeat construction transforms the competitive situation into a resultative one by means of the total (accusative) object – the SAD beats the SAR. Additionally, the spatio-temporal aspects of the root verb affect the interpretation of the construction.

CSDs have a different status in terms of which constructions they tend to adjust. Particularly flexible seem to be the verbs taking the Responsibility Shift Construction; the discussion in 5.3.1 showed that *syötä(ty)ttää* [eat-caus-(caus)-caus] and *juota(tu)ttää* [drink-caus-(caus)-caus] can occur in addition to the prototypical use in the Power Misuse Construction, the Responsibility Shift Construction and the Emotive Causative Construction.

Notice that these verbs belong to the medium transitivity CSD group (see section 4.3), the group of verbs that were found to be the most flexible regarding syntactic alterations. The constructional behaviour thus seems to support the flexibility characteristics of these verbs. An additional unifying aspect is related to the morphophonological form of the verb; the discussion of the RSC verbs in section 5.3.1 indicated that the reflexive *U*-element in the causative morpheme combination is associated with the Emotive Causative Construction. The morphophonological aspects of the causative suffix combinations are thus not insignificant – there is a general tendency for the (*ttA*)-*UttA* suffix to specialise in emotive causative interpretation and the morphological variants of two causative morphemes without the *U*-element (*syötättää/juotattaa*) are more generally responsibility shift verbs (obviously, a more precise frequency assessment could be done using delimited material).

The verbs occurring in the emotive causative pattern in my material are *ajeluttaa* (< *ajaa* ‘drive’), *potkituttaa* (< *potkia* ‘kick’), *katsotuttaa* (< *katsoa* ‘watch’), *pyöryttää* (< *pyöriä* ‘spin’), *puhalluttaa* (< *puhaltaa* ‘blow’), *vapisuttaa* (< *vapista* ‘shudder’), *nypityttää* (< *nyppiä* ‘pluck’), *hyppyttää* (< *hyppiä* ‘jump frequently’), *leikityttää* (< *leikkiä* ‘play’), *opituttaa* (< *oppia* ‘learn’) and *ajatuttaa* (< *ajaa* ‘drive’ / *ajatella* ‘think’). Examples describing this phenomenon are given in (3-9). The roots of these derivatives can be categorised as verbs encoding self-agentive activity; the sentences can be paraphrased as ‘feel like doing the root verb activity’ or ‘feel an urge to do the root verb activity’. An exception is *vapisuttaa* ‘make s.o. shudder’ in (3): it differs from the other verbs presented here in that the SAR’s activity lacks the control feature and describes a physiological state; its semantic field is psychophysical. Note that even the verb *kyykyyttää* (9) can be derived further with the *U-ttA*. The verb *ajatuttaa* is an exceptional case in that it breaks up to the root verb *ajaa* ‘to drive’ consisting of two causative morphemes (*ajatu-tta*); its regular denotation is ‘make s.o. drive’ (< *ajattaa* < *ajaa*). However, *ajatuttaa* is also associated with the root *ajatella* ‘to think’ in the meaning of ‘s.t. makes me think’, even though the causative derivative of *ajatella* would be *ajatteluttaa* (examples with ‘make s.o. think’ are (5a-b) and ‘make s.o. drive’ (10a) below)<sup>61</sup>.

<sup>61</sup> The Dictionary of Finnish Dialects actually gives the form *ajatteluttaa* [think-caus] as the second reading for the verb *ajattaa*, used in some places in Ostrobothnic dialects and in others in Carelian dialects: (*ajatuttaa*: 1) ‘panna ajamaan’, ‘ajattaa’; 2) *ajatteluttaa* (POH paikoin, KAR paikoin.). The Internet data thus reflects this dialectal correlation.

- (3) *puhalluttaa* [blow-caus] ‘blow/puff out’  
*vapisuttaa* [shudder-caus] ‘make s.o. shudder’

*Bändejäkään ei kai kovin montaa nähty, Neljä Ruusua ja Apulanta ja Trio Niskalaukaus ainakin. Meininki oli silloin kyllä ihan hyvä. Kylläpä se vieläkin **puhalluttaa** ja **vapisuttaa**. Jospa se tästä.*

‘We didn’t see that many bands, just Neljä Ruusua and Apulanta and Trio Niskalaukaus. The atmosphere was still pretty good at that point. It still **makes me breathe out** and **shudder**. Well, that’s it.’

(<http://chat.yle.fi/ylex/ubbthreads/showthreaded.php?Cat=&Number=973033&page=&view=&sb=5&o=&vc=1>, 24.11.2005)

- (4) *potkituttaa* [kick-caus-caus] ‘make s.o. kick; feel like kicking’

*kovasti kyttääjäukkoa myöskin **potkituttaa**, erinäisten ihmisten (lue vuokralaisten) jalat sekä autot vaaravyöhykkeessä.....*

‘...the man who stalks everyone also **feels** very much **like kicking**, diverse persons’ (read tenants’) legs and cars are in danger...’

(<http://www.kytaaajat.net/luettelo/t2.php4?halutupaikka=Kaarina>, 5.6.2005)

- (5a) *ajatuttaa* [drive?- caus-caus] ‘make s.o. think’

*Ensinnäkin minua **ajatuttaa** pojan pituus. Hän kasvaa alinta kasvukäyrää tasaisesti ja on tällä hetkellä 95,5 cm pitkä ja painaa 14 kg.*  
 ‘Firstly, the boy’s height **makes** me **think**. He is growing according to the lower growth curve and at the moment is 95.5 cm long and weighs 14 kg.’

([http://www.verkkoklinikka.fi/netdoctor/browse\\_topic\\_cust.xsp?topicOID=997359552\\_666\\_62e&sortByTimeAsc=false](http://www.verkkoklinikka.fi/netdoctor/browse_topic_cust.xsp?topicOID=997359552_666_62e&sortByTimeAsc=false), 24.10.2005)

- (5b) *Sepä tässä itseänikin **ajatutti** kovassa kritiikissä. Itselläni on kyllä jäänyt ikäviä muistoja lastentarha-ajalta, ilmeisen traumaattisia, sillä niiden osuus tuolta ajalta on kohtuullisen suuri.*

‘That’s what **got** me **thinking** about harsh criticism. I have bad memories myself from my kindergarten days, obviously traumatic, since the proportion of them is fairly large.’

(<http://keskustelu.kauppalehti.fi/5/i/keskustelu/thread.jspa?threadID=110960&start=90&tstart=100>, 24.10.2005)

- (6) *ajeluttaa* [drive-fre-caus] ‘make s.o. drive’

*Paraatin pääte pisteessä Hämeenlinnan kauppatorilla tapahtuu perinteinen kiertovanteen luovutus. Luvassa on myös rokkenrollia, musiikkia paukuttaa Goodmans – yhtye. Jos paraatiajona, puheiden, bändin ja ystävien tapaamisen jälkeen yhä **ajeluttaa** niin Ahveniston*



*moottoriradalla voi ajaa aina 18:00 asti hintaan 15,- EUR per kuski.*  
 ‘The traditional handover takes place at the end-point of the parade, at Hämeenlinna market. There will also be rock’n’roll with the band Goodmans. If you still **feel like driving** after the parade, the run, the talks, the band and meeting your friends, you can drive on the Ahvenisto race track until 6.00 pm for 15 EUR per driver.’  
 (<http://www.bajahill.net/mpuutiset0404.html>, 24.10.2005)

(7) *katsotuttaa* [watch-caus-caus] ‘feel like watching’

*Mutta yleensäkin katson elokuvan vasta kun tuntuu että olisipa kiva katsoa, sen sijaan että valkkaisin hyllystä "minkä katsoisin tänään" – tyylillä - jos ei katsotuta, luen vaikka mieluummin jotain.*  
 ‘But overall I only watch a movie if I feel like it would be nice to watch, instead of going on a “what will I watch today” kind of thing – if [I] **don’t feel like watching**, I tend to read something instead.’  
 (<http://www.dvdplaza.fi/forums/showthread.php?t=16192&page=2&pp=20>, 9.11.2005)

(8) *leikityttää* [play-caus-caus] ‘feel like playing’  
*opituttaa* [learn-caus-caus] ‘feel like learning’

*Lapselle turvataan mahdollisuus leikkiä kun leikityttää ja oppia kun opituttaa.*  
 ‘The child will have the chance to play when they **feel like playing** and learn when they **feel like learning**.’  
 ([http://www.minedu.fi/opm/ministerio/organisaatio/haatainen\\_puheet/lastentarha.html](http://www.minedu.fi/opm/ministerio/organisaatio/haatainen_puheet/lastentarha.html), 7.3 2005)

(9) *kyykytyttää* [squat-caus-caus] ‘feel like curling up; feel like being oppressed/victimised’

*Voi voi kyllä nyt kyykytyttää. Antakee armoo.*  
 ‘Oh dear now [I?] **feel like curling up** (going into a squat). Have mercy!’  
 (<http://www.jfiles.fi/asikkalalainen/bbs/keskustelut1/displaymessage.asp?mid=43732&iRC=0&pts=11>, 30.8.2005)

Nevertheless, the *UttA*-morpheme does not exclude readings other than the emotive causative sense either, as for instance with *ajatuttaa*, associated with *ajatella* ‘to think’ in examples (5a-b) denoting ‘make s.o. think’; this verb can also be used as a derivative of the root *ajaa* ‘to drive’ as in (10). The causatives *lenkityttää* ‘make s.o. jog’ and *leikityttää* ‘make s.o. play’ are given in (10b).

(10a) *ajatuttaa* [drive-caus-caus] ‘make s.o. drive’

*On aivan järjetöntä, että ”ympäristöystävällisesti” ajatteleva KL*

***ajatuttaa** sinistä bussiaan turhaan asuinalueen läpi.*

‘It’s insane that the ‘pro-environment’ HKL **has** its blue bus **drive** through the residential area when it doesn’t need to.’

(<http://www.kulosaarelaiset.fi/forum/messages/23/38.html?Keskiviikk010Joulukuu2003klo1655>, 24.10.2005)

(10b) *lenkityttää* [jog-cause-cause] ‘make s.o. jog’

*leikityttää* [play-cause-cause] ‘make s.o. play’

*Tarvitsen urheilullisen hoitajan, joka jaksaa **lenkityttää** ja **leikityttää** Nikkeä.*

‘I need a sporty trainer who will **get** Nikke **jogging** and **playing**.’

([http://www.geocities.com/kennel\\_beadyeyeds/nikke.html](http://www.geocities.com/kennel_beadyeyeds/nikke.html), 7.3.2005)

Are there other assemblages of CSD verbs apart from those based on the constructions discussed in this chapter? Basically, the syntactic-semantic classes discussed in chapter 3 can be seen as a general basis for verb groupings according to their transitivity features (with the reservation that the verbs can change group under certain conditions). In addition to the verb clusters attracted by constructions or the morphosyntactic form, my material reveals that there are several relatively novel verbs derived with the *ttA*-suffix. These verbs seem not to fit into any of the abovementioned groups. It is remarkable that these novel derivatives are not derived, for instance, using the general denominal verb formation suffix *tA*, even though the causative content is lacking. These verbs are found in online jargon, especially information technology discussions.

Consider some examples of these verbs. The examples in (11a-e) feature *guruttaa* ‘to fix s.t.’, (12a-c & 13) *warettaa* and *imuttaa* ‘to download’, (14a-b) *hypettää* ‘to hype, over-advertize’ and (15) *googlettaa* ‘to do a Google search’. *Guruttaa* is a verb that can be used as a causative (see examples (11a-b)) in the meaning of ‘to fix s.t., sort s.t. out’ or as a non-causative in the sense of ‘be good at s.t.’ (11c-d) or ‘consider s.o. a guru’ (11e). The verb *hypettää* also lacks causative content. The verbs *warettaa* and *googlettaa* express activities that have become common relatively recently, in connection with Internet use. Downloading files or searching for information on the Internet creates an analogy with the verb *haetuttaa* ‘make s.o. fetch’. The verbs *waretta* and *hypettää* are borrowed from English, used in comparable contexts with the corresponding English verbs. There is also a synonym for *warettaa* and *imuttaa* derived with the suffix *tA*, the verb *downloadata*, occurring in example (12a). Why is *ttA* not used here? I suppose one possible reason is morphophonological motivation: the stem includes a compound with two stressed syllables, so the *ttA* would add

another secondary stress to the derivative. ‘Contraction verbs’ (Fin. *supistumaverbit*) of the type vowel+*tA* are seen to be an especially expansive type when it comes to the innovative lexicon of Finnish (see for instance Karlsson 1983: 209-210). In light of the examples below, the causative morpheme *ttA* appears to be a suffix to be reckoned with in novel word formation.

(11a) *guruttaa* [guru-caus] ‘to act as an expert, fix s.t’

*Tällasta ihmettelen, että osaaks joku guruttaa sellasen infon, et millasta PC-konetta vastaa 800 G3 + 640MB ram. mäkin läpyskä Lähinnä musakäytössä.*

‘I’m wondering whether someone could **tell** me what PC appliance equates to an 800 G3+ 640 MB ram Mac laptop. Mainly for music use.’ (<http://www.stealthunit.com/message.aspx?intBoardID=6&intMessageID=167097>, 7.11.2006)

(11b) *Kuka guruttaa layoutin oikein?*

‘Who’s going to **sort out** the layout?’

(<http://www.antenniosasto.com/bbs/viewforum.php?f=17&sid2b3b6a5142d2ea088854893f35dcaac9>, 7.11.2006)

(11c) *Mutta silti, minun mielestä kovimmat tyypit on niitä, jotka guruttaa kaikki tyylit ja soittaa sitten sitä, mitä tilataan /.../*

‘Still, in my opinion the toughest guys are those who **excel** [=are gurus of] at all styles and play what they’re told to play.’

(<http://muusikoiden.net/keskustelu/posts.php?c=52&t=150611 &co=240>, 7.11.2006)

(11d) - *Yritä löytää pitkäaikaistyötön joka ei olisi masentunut ja alkoholisti :) - Tunnen useammankin tällaisen ikipummin. Kukaan näistä ei juo tippaakaan alkoholia. Yksi guruttaa Wowissa ketä tahansa ja toinen on haka eräässä 3d-nettiräiskinnässä. Ei siis kannata yleistää.*

‘- Try to find a long-term job-seeker who isn’t depressed and alcoholic - I know more than a few bearded bums like that. None of them drinks a drop of alcohol. One **beats** everyone at Wow<sup>62</sup> and another is a pro at 3D net shooter. So we shouldn’t generalize.’

(<http://keskustelu.plaza.fi/Muropaketti/bbs/t568564,775>, 7.11.2006)

(11e) *Ihmisillä on kautta aikojen ollut tapana alkaa palvoa, "guruttaa" henkilöitä, joiden uskotaan olevan henkisesti muita korkeammalla tasolla.*

‘People have always idolized and **considered** people who are believed

<sup>62</sup>Wow (World of Warcraft) is a magazine specializing in computer role-playing games.

to be spiritually on a higher plane than others **gurus**.’  
 (<http://www.astro.fi/forum/index.php?topic=10365.60>, 7.11.2006)

(12a) *warettaa* [Eng. ware-caus] ‘to ware’

*Ja helpointa olisi varmaan Laten koneelta ne downloadata (tai warettaa, kuten piireissä sanotaan), jottei tarvitse levyjä sen takia alkaa polttelemaan.*

‘And it would probably be easiest to **download** it (or **ware** it, as they say in these circles) from Late’s computer, so (you) would not need to burn discs.’

(<http://www.suunta.org/forum/viewtopic.php?t=578>, 7.11.2006)

(12b) *"No kuka sellaista enää käyttää?" Aika monikin. Sellainen, jolla ei ole resursseja päivittää tai moraalivajetta warettaa. Nähdäkseni aivan hyödytön tuollainen vain uusin on olemassa eikä muulla ole merkitystä -asenne. :-/*

‘“Who uses stuff like that any more?” Quite a few people do. Someone that doesn’t have the resources to update or the moral deficit to **ware**. As I see it, the *only what’s new exists and nothing else matters* attitude is absolutely useless. :-/’

(<http://www.hopeinenomena.net/ShowPost.aspx?PostID=16133>, 7.11.2006)

(13) *imuttaa* [suck-caus] ‘to download’

*Napster tarjoaa myös kuukausimaksutyypistä palvelua, jossa kymmenellä taalalla saa imuttaa niin paljon kuin letku antaa periksi.*

‘Napster also provides a monthly scheduled payment service where you can **download** as much as it will allow.’

(<http://sektori.com/uutiset/5105/napster>, 7.11.2006)

(14a) *hypettää* [Eng. hype-caus] ‘to hype’

*Bändi on Ruotsissa Grammy-nominoituna parhaana hardrock-yhtyeenä ja lehdistö hypettää levyä sanoin tämä on se mestariteos mitä Axl Rose on luvannut tehdä 15 vuoden ajan!*

‘The band has been nominated for a Grammy as the best hard rock band in Sweden, and the press are **hyping** the record as the masterpiece that Axl Rose has been promising to make for 15 years!’

(<http://www.click2music.fi/finland/viikkarit/2006/vk04/vk04.htm>, 7.11.2006)

(14b) ”*Olen pikkuhiljaa kääntynyt konservatiivisemmaksi: työt on erikseen ja vapaa-aika erikseen. Luulen, että moni muukin on kokenut saman ilmiön. Vielä kolme–neljä vuotta sitten alan tapa oli, että äijät lähtivät päivän jälkeen kaljalle puhumaan töistä, mutta se on kyllä hävinnyt. Ei sitä vanhemmiten jaksa enää hypettää, että työ on minun intohimoni*”,  
Tiainen naurahtaa.

‘Little by little I’ve become more conservative: I keep my job and my free time apart. I think a lot of others have experienced the same thing. And yet three or four years ago it was still the thing in the branch for the guys to go off and talk about the job at the end of the day over a beer – but this has disappeared. When you get older, you can’t be bothered **hyping** your job as your passion any more!’ Tiainen says with a laugh.

(<http://www.helsinki.fi/ylioppilaslehti/2004/040116/juttu4.html>, 7.11.2006)

(15) *googlettaa* [google-caus] ‘do Google searches’

*Millä nimellä googletan kaapinovien..niitä mistä otetaan kiinni avatessa?*

‘What name should I use to **google** the closet doors – those ones you grasp when you open them?’

(<http://kaksplus.fi/keskustelu/t1361370>, 4.12.2008)

Another phenomenon in connection with the *ttA*-derivatives is cases without any apparent motivation for the derivation. Maija Länsimäki (1987: 150, footnote 80; 182–183) has noted in her study of deverbal instrumentative substantives that synonymy of the root word and the derivative is not uncommon, although such processes could be thought to be restricted by the semantic-economical principles. As reasons for this phenomenon, she proposes the need to fill a certain type of sememe, or to strengthen a weak semantic feature of the root by means of the derivative suffix. Is the *ttA*-suffix used to strengthen the root verb semantics in the following examples, where the derived verb has maintained the syntactic and semantic characteristics of its root? The examples with *voimisteluttaa* (< *voimistella* ‘do gymnastics’) (16a-b), *muistuttaa* (< *muistuttaa* ‘remain’) (17a-b) and *saatattaa* (< *saattaa* ‘may’) (18) illustrate this occurrence. Sentences (16a-b) contain an implication of indirectness; the focus is on the body part, visualized as disunited from the body. The verb *muistuttaa* in (17a-b) seems to function exactly as its root verb *muistuttaa* ‘to remain’ with one *ttA*-suffix less. An interesting case is *saatattaa* in (18), since its root verb is a modal verb; also, the derivative occurs with an infinitive (*olla* ‘to be’).

- (16a) *voimisteluttaa* [do gymnastics-caus] ‘make s.o. do gymnastics’

*Laskimovoimistelu tehostaa laskimovirtausta. Jos istut kauan paikallasi tai teet seisomatyötä, on tärkeää voimisteluttaa jalkoja useita kertoja päivässä.*

‘Vena gymnastics strengthens venous flow. If you sit for a long time or work on your feet, it is important to **get** your feet **doing gymnastic exercises** several times a day.’

(<http://www.terveydenhoitouutiset.fi/thu0501/5.htm>, 27.2.2005)

- (16b) *Mutta kaksi- tai monikielisyys voimisteluttaa myös aivoja.*

‘But bilingualism or multilingualism **makes** the brain **do gymnastics**, too.’

([http://www.migrationinstitute.fi/db/articles\\_e/art.php?artid=40](http://www.migrationinstitute.fi/db/articles_e/art.php?artid=40), 27.2.2005)

- (17a) *muistututtaa* [remind-caus]

*Muistututan vain näistä mukavista ja hassunhauskoista bileistä! Että ilmoittautumaan ja reippaasti, rööh!*

‘I just **remind** (you) of that funny party! Enrol, and do it quickly, oink!’

(<http://www.grl.fi/forums/viewtopic.php?t=1987>, 27.9.2004)

- (17b) *Purjehtijat muistututtavat, että lähiliikuntapaikalla harrastus ei ole vanhempien innosta kiinni.*

‘The sailors **remind** (us) of that in the neighbouring exercise yard the hobby does not depend on the parents’ enthusiasm.’

(<http://www2.slu.fi/lehtiarkisto/verkkolehti.200018.uutinen.1025>, 27.9.2004)

- (18) *saatattaa* [may-caus]

*ei nyt taas tule kuuppaan mitään järkevää ideaa ja saatattaa olla huomenna pitkäkin päivä.*

‘I’m not getting any sensible ideas again. It **might** be a long day tomorrow.’

([http://susi1.net/e107\\_plugins/forum/forum\\_viewtopic.php?86678.1230](http://susi1.net/e107_plugins/forum/forum_viewtopic.php?86678.1230), 23.4.2007)

The derivational processes can be highly idiosyncratic. It is not unusual for the derivation to comprise a verb’s idiomatic surrounding. Sometimes there is an additional causation; sometimes the meaning remains practically identical to the root verb’s semantics. An example is the verb *tanssittaa* ‘make s.o. dance’, discussed in connection with the Power Misuse Construction (see section 5.2.6), that is used in the structure *Tanssittaa*

*jonkun pillin mukaan*, meaning ‘have s.o. dance to s.o.’s tune’. Consider example (19), a derivation with the *ttA-UttA*-suffix of the utterance *raapia päätä* ‘scratch the head’ or ‘be puzzled about something’:

- (19) *päätä raavituttaa* [head-part scratch-caus-caus] ‘make s.o. scratch their head’

*Kyllä alkaa mennä usko koko edustuslaitokseen, ja päätä raavituttaa ketä seuraavaksi uskaltaa mennä äänestämään.*

‘Faith in the representative institution starts waning, and the question of who you dare vote for **makes** [you] **scratch your head**.’  
([http://www.kuhmonet.fi/kuhmonetjutut/\\_viestit1/0000014e.html](http://www.kuhmonet.fi/kuhmonetjutut/_viestit1/0000014e.html), 29.9.2004)

It is not unusual for frequent verbs to establish tight collocative combinations with adverbial modifiers. By derivation, these verbs may keep their sentential setting. An example of such a verb is *ottaa* ‘to take’. In my material, the following occurrences of the CSD *otattaa* ‘make s.o. take’ are found in lexical surroundings typical of its root verb:

- (20) *otattaa päähän* ‘rile, get at’  
*otattaa lujille* ‘be put through the wringer’  
*otattaa/otatuttaa haltuun* ‘take over’  
*otattaa/otatuttaa pois* ‘take away’  
*otattaa veke* ‘take away’  
*otattaa alas* ‘take down’  
*otattaa kiinni* ‘seize, capture’  
*otattaa yhteyttä* ‘make contact’  
*otattaa ja jättää* ‘take and leave’

I will give some examples to illustrate the use of this ‘collocative derivation’. Note that in (21a-c) the causative suffix is not with the causative content.

- (21a) *otattaa yhteyttä* [take-caus contact-part] ‘make contact’

*Yksin taistellen kaikki on raskaampaa. Siksi uskon asioiden jonkin verran selkiävän, kun saatte keskusteltua kunnan virkailijan kanssa. Rohkeasti vain otattamaan yhteyttä sinne päin.*

‘Fighting on your own, everything is harder. Therefore I believe things will become clearer to some degree once you get to discuss them with a communal official. Be brave and **make contact** in this way yourself.’  
(<http://www.omaishoitaja.fi/viewtopic.php?f=6&t=580>, 5.4.2009)

- (21b) *otattaa lujille* [take-caus hard-pl-all] ‘be put through the wringer’

*Nyt otattaa vähän lujille olla töissä, kun silmät on niin turvoksissa kaiken itkeskelyn ja murehtimisen takia.*

‘It is **hard** to be at work at the moment, with my eyes so puffy after all that crying and worrying.’

(<http://www.agronet.fi/dcforum/Agronet/DCForumID1/5709.html>, 5.11.2005)

- (21c) *otattaa päähän* [take-caus head-ill] ‘rile, get at’

*joo tulee ne liput muuntiin 4. päivä...minuakin otattaa päähän jos näyttelijät vaihtuvat...eihän siinä sitten olis enää mittää järkiä...*

‘Yeah, those tickets go on sale on the 4<sup>th</sup>... it will **annoy** me if the actors are changed... it wouldn’t make sense any more...’

(<http://www.telkku.com/keskustelut?tila=viestit&osasto=500&vk=350>, 5.11.2005)

- (21d) *otatuttaa pois* [take-caus-caus away] ‘take away’

*kattopelti sattuu olemaan terävä väärästä kohtaa... Ens viikolla kuulemma saa jo tikit otatuttaa pois...*

‘The roofing sheet happened have a sharp edge in the wrong place. Next week, apparently, the stitches can **be taken out...**’

(<http://chat.yle.fi/ylex/ubbthreads/showflat.php?Cat=&Number=505733&page=0&view=collapsed&sb=5&o=&fpart=23&vc=1>, 5.11.2005)

Compound CSDs are also possible, as examples (22-24) show. Note that in examples (22-23), the causative suffix is *UttA* and in example (24) *ttA-ttA-UttA*. In examples (22) and (24), the verbs encode a reflexive activity, directed at the subject argument.

- (22) *kauneusleikkauttaa* [implement.cosmetic.surgery-caus] ‘make s.o. do cosmetic surgery on oneself’

*Demi Moore haluaa kauneusleikkauttaa polvensa*

‘Demi Moore wants to get cosmetic surgery (**make** [someone] **do cosmetic surgery**) on her knees.’

(<http://www.selehti.fi/viihdearkisto.php?id=1016>, 20.12.2004)

- (23) *salamurhauttaa* [crypto.murder-caus] ‘make s.o. assassinate’

*Palattuaan Liu Bang nähtävästi päätti salamurhauttaa vaimonsa ja vanhimman poikansa, mutta vanhat vammat vaativat hänen henkensä vuonna 195 e.a.a. 61 vuoden ikäisenä ennenkuin hän kerkesi antaa määräyksen.*

‘After coming back, Liu Bang apparently decided to **assassinate**



his wife and oldest son, but his old injuries got the better of him in 195 B.C at the age of 61, before he got around the decree.'

([http://www.radio86.com/view\\_dynasty.php?id=5](http://www.radio86.com/view_dynasty.php?id=5), 20.12.2004)

- (24) *pakkosyötättyttää* [compulsion.eat-caus-caus-caus] 'make s.o. feel compelled to eat'

*Sanotaan nyt tuo vielä kerran; jokaisella on oikeus makuutta ja nostatuttaa, **pakkosyötättyttää** ja vaipotuttaa itseään täysin autettuna vaikkka ikijähän asti*

'Let's say this one more time: everybody has the right to make [the nurses] let [them] lie in bed and lift [them], let [them] **make** [them] **eat** and put them in diapers completely assisted until the permafrost sets in.'

([http://www.lansivayla.fi/lansivayla/discussion.php?item=20882 &t=1081845289](http://www.lansivayla.fi/lansivayla/discussion.php?item=20882&t=1081845289), 20.12.2004)

To summarize the discussion about the salient features of CSDs, I have collated some of the CSDs discussed above with their occurrences in the main constructions defined in this chapter in Table 5, which presents both the verb in question and its root. Two central semantic characteristics, motion and activity, are also given. The notion of motion in this table represents self-agentive movement, where the mover undergoes a transition in respect to a reference point.

Table 5. Occurrence of some CSDs in causative constructions

CSD	Root	Root verb properties		CSD constructions			
		Motion	Activity	PMC	RSC	ECC	Resp. SAR
<i>juoksuttaa</i> run-caus	<i>juosta</i> 'run'	+	+	+			
<i>ryömittää</i> crawl-caus	<i>ryömiä</i> 'crawl'	+	+	+			
<i>pyörittää</i> spin-caus	<i>pyöriä</i> 'spin'	+	+	+			
<i>tanssittaa</i> dance-caus	<i>tanssia</i> 'dance'	+	+	+			
<i>hyppyttää</i> jump-caus	<i>hypätä</i> 'jump' (v or n)	+	+	+			
<i>kyykyttää</i> squat-caus	<i>kyykky</i> 'squat' (n)	+	+	+			
<i>kyykytellä</i> squat-caus- fre	<i>kyykyttää</i> 'make squat'	+	+	+		(+)	
<i>liikuttaa</i> move-caus	<i>liikkua</i> 'move'	+	+			+	+
<i>kuntoiluttaa</i> train-caus	<i>kuntoilla</i> 'train'	+	+			+	+
<i>aja(tu)uttaa</i> drive-caus	<i>ajaa</i> 'drive'	+	+	(+)		+	
<i>maksattaa</i> pay-caus	<i>maksaa</i> 'pay'		+	+			?
<i>tapattaa</i> kill-caus	<i>tappaa</i> 'kill'		+				?
<i>haetuttaa</i> fetch-caus- caus	<i>haettaa</i> > <i>hakea</i> 'fetch'	+	+				
<i>syötättää</i> eat-caus- caus	<i>syöttää</i> > <i>syödä</i> 'eat'		+	+	+	+	
<i>teettää</i> do-caus	<i>tehdä</i> 'do'		+				+
<i>ihailuttaa</i> admire-caus	<i>ihailia</i> 'admire'		+				
<i>tunnistuttaa</i> recognize- caus	<i>tunnistaa</i> 'recognize'		+				

Hence a motion verb does not necessarily adapt the PMC, as in *liikuttaa* ‘make s.o. move’ and *kuntoiluttaa* ‘make s.o. train’, encoding an activity with more of a positive connotation. These verbs denote a more general type of motion than the likes of *juoksuttaa* ‘make s.o. run’ or *hyppyttää* ‘make s.o. jump’. The general verb *teettää* ‘make s.o. do’ adapts only the Responsible Actor Construction. Some CSDs do not, to my knowledge, occur in the constructions at all, such as the mental activity verbs in Table 5 *ihailuttaa* ‘make s.o. admire’ and *tunnistuttaa* ‘make s.o. recognize’; consider an example including *tunnistuttaa* in 25:

(25) *tunnistuttaa* [recognize-caus] ‘make s.o. recognize’  
*kokeiluttaa* [try-caus] ‘make s.o. try’

*Lyhyiden terapioiden taustalla on peruskäsitys inhimillisen muutoksen luonteesta ja (usein - ei aina) kognitiivinen lähestymistapa **tunnistuttaa** omia ajattelu- ja kokemistapoja ja **kokeiluttaa**/asentaa uusia.*

‘The bckground to short course therapy is the basic concept of human change and often (not always) the cognitive approach of **making** you **recognize** [your] own way of thinking and experiencing and **making** you **try**/establish new ones.’

(<http://keskustelu.skepsis.fi/html/KeskusteluViesti.asp?ViestiID=134929&AiheID=5>, 28/9, 2004)

The discussion in this section suggests that there are various, heterogenous criteria behind the groupings of verbs. A watertight classification of verbs seems a rather complicated task, and context-sensitive derivative verbs are no exception in this respect. The constructional meanings are clearer in connection to certain verbs, as well as in certain contexts; the meaning of a CSD is thus highly influenced by its sentential and contextual surroundings. The ability of CSDs to adapt constructions varies largely; the constructions provide a template for language users to try verbs in these patterns and to form natural verb groups. Single verbs may take idiosyncratic routes on their way to becoming verbs assigning a constructional pattern. The verb meaning also evolves in compliance with its involvement in constructions.

### 5.4.2 CSDs and Internet genres

The topic of this section is the relationship between the textual and semantic aspects of CSDs in light of Internet data. A proper textual or genre analysis of CSDs is not the goal of this study, but I would like to present some observations of the genre effect on the use of CSDs and constructions and the function of CSDs in different text types. My aim is to highlight general tendencies related to causative derivatives and language use material, with indications for future research.

The language data in my study was collected mainly from the Internet. I have not done a frequency study of my Internet data, except for the samples of *juoksuttaa* ‘make s.o. run’ (see 5.2.1) and *kyykyyttää* ‘make s.o. squat’ (see 5.2.4.2) based on the Google results. Material of this type of mixed source can generally be argued to call for restrictions, because of the heterogeneous results. As discussed in section 2.3.1, one way to approach Internet data is to place limits on, for instance, a discussion group within certain temporal limits or to confine the subject of study to certain websites. In my study, the main reason for collecting the relevant results qualitatively from very different sources is due to the multifunctional nature of CSDs. Another reason is that I attempt a preliminary mapping of these derivatives. The highly heterogeneous material available on the Internet represents different language and text variants. However, I suggest that online texts may give an indication of the tendencies of the situational contexts in which a linguistic phenomenon is able to occur.

Crystal (2001: 6) characterises the large range of language used on the Internet with the term ‘language variety’, “a system of linguistic expression whose use is governed by situational factors”. Here I will use the term ‘genre’ for language used in such a distinguishable situation; a general division can roughly be made between formal and informal genres. The Internet as a medium does not merely reflect innovative language and genres. One basis of it is the mass communication text tradition that has developed rapidly and become easily accessible over the Internet’s history. The characteristic Internet phenomenon of communities bringing together enthusiasts in special fields reflects a basic human phenomenon – similar-minded people have always discussed topics they are concerned about or find interesting. The medium is different, which obviously sets conditions on language. This language situation may therefore be generalised so that the assortment of Internet text consists of both well-established genres and dynamic yet not fully formed genres. The virtual communication taking place on the Internet makes it possible for us to observe language development in a new way. Online language reflects the contemporary language situation – whereas the traditional source of variation was based on regional factors, the Internet connects people with similar interests and similar or dissimilar views.

What do CSDs signal in discourse comprising different genres and topics? Conventionalised language use motivated by social needs tends to display typical lexico-grammatical choices. A salient characteristic of CSDs is that distribution among the Internet genres they occur in is noticeable. As mentioned in section 2.3.1, previous observations about the contextual and stylistic properties of CSDs indicate that they form part of formal and concise language (Kytömäki 1989). In light of the contemporary language use that my material reflects, this claim still partly holds. Examples (1-4) show the use of CSDs in highly formal and restricted legal texts. These samples reflect the hierarchical system of the decision-maker level, the enforcement level and the persons towards whom the law is directed. As such, these CSDs specify legal concepts. Note that in examples (1, 3 and 4) both the causative predicate and its root verb are coordinated with the adversative conjunction *tai* ‘or’. Since precise formulation is important in legal texts, the root verb and the derivative are contrasted in order to explicate that it is a question of an action that can be performed by the subject argument itself or via an intermediary agent. Hence the productive potential of CSDs is functional in this type of genre. Interestingly, collocative verb phrases also occur in formal texts; consider *ottaa tai otattaa kiinni* ‘capture or make s.o. capture’ in (3) and *ottaa haltuun tai otattaa haltuun* ‘take over or make s.o. take over’ in (4). Note also that there are no affective-attitudinal implications involved in the legal text examples.

(1) *kuulusteluttaa* [question-caus] ‘make s.o. question’

*Hänen on voitava kuulustella tai kuulusteluttaa vastapuolen todistajia sekä saada hänen puolestaan esiintyvät todistajat kutsutuiksi ja kuulustelluiksi*

‘It has to be possible for him **to question** or **make** someone **question** the other party’s witnesses and have the witnesses representing him called in and interrogated.’

(<http://www.fredmanmansson.fi/lapsisop.htm>, 15.11.2005)

(2) *avauttaa* [open-caus] ‘make s.o. open’  
*etsityttää* [seek-caus-caus] ‘make s.o. find, seek, look’

*Ulosottomiehellä on oikeus avauttaa lukkoja ja ovia sekä etsityttää huoneita ja säilytyspaikkoja, jos täytäntöönpanossa sitä tarvitaan.*

‘The distrainer has the right to **make** [s.o.] **open** the locks and the doors, and **make** [s.o.] **search** the rooms and the depositories, if it is needed.’

(<http://www.finlex.fi/linkit/sd/20030528>, 13.1.2005)

(3) *otattaa* [take-caus] ‘make s.o. take’

*Suojelupoliisin päälliköllä, apulaispäälliköllä ja toimistopäälliköllä on oikeus **ottaa tai otattaa kiinni** sekä tarkastajalla, ylietsivällä ja etsivällä **ottaa kiinni** kuulustelua varten henkilö, jota todennäköisin perustein epäillään valtakunnan itsenäisyyttä tai sen laillista valtio- ja yhteiskuntajärjestystä vastaan kohdistuvasta taikka yleistä järjestystä ja turvallisuutta vaarantavasta rikoksesta.*

‘The director, deputy director and office manager of the Security Police have the right to **bring** or **have** the inspector, chief detective and detective **bring in** a person suspected of a crime against the independence of the state or its legal system of government and society or threatening public order and security for interrogation.’  
(<http://www.finlex.fi/fi/laki/alkup/1966/19660085>, 5.11.2005)

(4) *otatuttaa* [take-caus-caus] ‘make s.o. take’

*/---/ on varmistuttava, että henkilöstöllä, jotka ovat vastuussa tarkastuksista, on oikeus **ottaa haltuun** tai **otatuttaa haltuun** kaupalliset asiakirjat.*

‘/---/ it must be ascertained that the personnel responsible for inspections have the right to **take over** or **make** someone **take over** the mercantile documents.’  
(<http://europa.eu.int/scadplus/leg/fi/lvb/l33030.htm>, 5.11.2005)

Examples of other genres making use of productive CSD denotations include advertisements (5) and official newsletters (6):

(5) *pesetyttää* [wash-cause-caus] ‘let s.o. wash’

*Pesulamme palvelee teitä kaikissa alan asioissa. Meillä voit **pesetyttää** ja huoltaa tekstiilisi matoista hääpukuun.*

‘Our laundry serves all of your needs. **Let us wash** and take care of your textiles, from carpets to wedding dresses.’  
(<http://www.nic.fi/~ruchdi/washinpesula/palvelut.html>, 29.9. 2004)

(6) *kaivattaa* [dig-cause] ‘make s.o. dig’  
*teettää* [do-caus] ‘make s.o. do’

*HTV:n verkkoon liitetyn taloyhtiön ei tarvitse **kaivattaa** kallista lisäkaapelia tai **teettää** erillisiä laiteasennuksia kiinteistön tiloihin*

‘A housing company connected to the HTV net does not need to **make** [s.o.] **dig** an expensive additional cable or **make** [s.o.] **organise** special equipment installations for the property.’  
(<http://www.htv.fi/lehdistotiedotteet.asp?year=2003&f=94&d=23735>, 5.6.2005)

The description of social hierarchies in connection with different kinds of activities obviously motivates the use of CSDs, as in texts discussing historical events.

(7) *toteuttaa* [execute-caus] ‘make s.o. execute, do’

*Mahmud II toteutti vallankaappauksen vuonna 1826 ja tuhosi vanhoilliset janitsaarit. Uudistuspolitiikalla ei ollut enää vastustajia.*  
 ‘Mahmud II **made** [his underlings] **carry out** the coup in 1826 and destroyed the conservative Janissaries. This crushed all opposition to his reform policies.’  
 (<http://www.uta.fi/~hipema/p5.htm>, 3.3.2006)

(8) *vangituttaa* [arrest-caus] ‘make s.o. imprison’

*kuulusteluttaa* [interrogate-caus] ‘make s.o. interrogate’  
*tuomituttaa* [sentence-cause] ‘make s.o. sentence’

*Emmanuel Le Roy Ladurie popularisoi kiehtovasti keskiajan historiaa Montaillou-teoksessaan. Sen rivienvälinen sankari ja konna ovat sama henkilö: Pamiers'n hiippakunnan piispa Jacques Fournier. Hän oli alueensa inkvisiittori, joka **vangitutti, kuulustelutti ja tuomitutti** satoja alueensa asukkaita kerettiläisyydestä epäiltyinä.*

‘Emmanuel Le Roy Ladurie popularized medieval history fascinatingly in his work *Montaillou*. The hero and villain was one and the same person: Jacques Fournier, Bishop of Pamiers. He was the region’s inquisitor, who **had** hundreds of inhabitants suspected of heterodoxy **imprisoned, interrogated and sentenced.**’

(<http://www.kiiltomato.net/?rcat=Muu+kirjallisuus&rid=590>, 5.11.2005)

The examples above have been quite neutral regarding the expression of power relationships. However, a formal text may also contain affective attitudinal implications. The next example is from news imparted by the Finnish channel Mtv3 on their website, reporting on a former headmaster who had been sentenced to pay a fine for bullying his pupils. The CSDs in (9) express the humiliating activity practised by the headmaster. The CSDs are *röyhtäyttää* ‘make s.o. burp’, *itkettää* ‘make s.o. cry’ and *konttauttaa* ‘make s.o. crawl’. Note that *röyhtäyttää* is related to the root verb *röyhtäistä*, which is a momentum derivative; the sentential context ascertains that the burper here is the SAR, not the SAD. Because of the expressive content of these verbs, they were even selected as the subheading of the news text.

- (9) *röyhtäyttää* [burp-caus] ‘make s.o. burp; burp’  
*itkettää* [cry-caus] ‘make s.o. cry’  
*konttauttaa* [crawl-caus] ‘make s.o. crawl’

**Röyhtäytti, itketti ja konttautti** (the subheadline)

*Oikeuden mukaan mies esimerkiksi itketti, röyhtäytti ja konttautti oppilaitaan. Mies myönsi teot, mutta piti niitä kasvatuksellisena menetelmänään.*

‘**Made to burp, cry and crawl on all fours**

According to the court, the man **made** his pupils, amongst other things, **burp, cry** and **crawl**. The man confessed his actions, but considered them to be educational methods.’

(<http://www.mtv3.fi/uutiset/arkisto.shtml/arkistot/rikos/007/05/529485>, 14.2.2008)

My material indicates that CSDs are common in newspaper texts, and bossy causatives in particular are used in headlines. Consider the following examples from online newspaper articles:

- (10) *maksattaa* [pay-caus] ‘make s.o. pay’

*Hallitus maksattaa veronkevennykset köyhillä.*

‘Government **makes** poor **pay** for lower taxes’

(<http://www.vasemmistoliitto.fi/eduskuntaryhma/arkisto/1119.html>, 29.9.2004)

- (11) *kyykyttää* [squat-caus] ‘make s.o. squat’

*Sikspäk kyykyttää sydäntä* ‘Six-pack **puts pressure** on heart’

(<http://www.tiede.fi/uutiset/uutinen.php?id=1336>, 17.11.2008)

- (12) *Taikaviitta kyykyttää karhukonnat*

‘Duck Avenger **beats** Beagle boys’

(<http://www.kvaak.fi/naytajuttu.php?articleID=964>, 17.11.2008)

- (13) *Teemu Selänne kyykytti Detroitia*

‘Teemu Selänne **beats** Detroit’

([http://yle.fi/urheilu/lajit/jaakiekko/nhl/2008/10/teemu\\_selanne\\_kyykytti\\_detroitia\\_125521.html](http://yle.fi/urheilu/lajit/jaakiekko/nhl/2008/10/teemu_selanne_kyykytti_detroitia_125521.html), 17.11.2008)

- (14) *kampittaa* [trip-caus] ‘trip s.o. up’

*Kilpailijaa yritetään kampittaa patenteissa*

‘Attempt to **trip up** competitor with patents’

(<http://www.tekniikkatalous.fi/tk/article32657.ece>, 10.11.2008)



The examples discussed in connection to CSD constructions indicated that CSDs are also quite common in less restricted and informal surroundings. Internet discussions can be seen to be an instance of situations of colloquial language, often with narrative and/or evaluative characteristics. Communication in discussion groups allows the participants to share their thoughts and opinions as well as comment on those of others (Hoffman 2007). A uniting factor behind the use of CSDs is the communities bringing together people with the same interests. Thus a topic of discussion based on a shared interest is often a source of specific, jargon-like language. CSDs can obtain special semantic content within these communities, with the result that some of them are only understood within the contextual environment. The CSDs functioning as legal terms presented above also occur in discussion situations (for instance *etsityttää* ‘make s.o. search’). The examples of *etsityttää* (15a-b) and *haetuttaa* (16a-b) (both meaning ‘make s.o. seek/search’) are taken from discussions held about orienteering. The Perceptual Causative Construction in connection with these verbs has become part of orienteering terminology, referring to a situation where the control points drive the participants’ seeking process:

(15a) *etsityttää* [seek-caus-caus] ‘make s.o. find, seek, look’

*Vauhtia olikin kuin mummolla metrisessä hangessa, mutta jotkut rastit antoivat silti etsityttää ennen löytymistä. illalla toivuttiin pettymyksistä pelaten ...*

‘We were moving like an old woman in a meter-high snowdrift, but some control points **had[us] looking** for them before they appeared. In the evening [we] recovered by playing...’

([http://www.kuopionsuunnistajat.fi/edustus/jutut/seikkailua\\_tn.rtf](http://www.kuopionsuunnistajat.fi/edustus/jutut/seikkailua_tn.rtf), 13.2.2005)

(15b) *Satu Vesalainen puolestaan oli tyytyväinen juoksun sujumiseen vaikka suunnistuksessa hänelle tulikin virheitä. Viitosrastin lippu etsitytti itseään melkein minuutin verran.*

‘Satu Vesalainen in turn was satisfied with the way the race went, even if she made some mistakes in the orienteering. The flag at the fifth control point **had her looking** for it for almost a minute.’

(<http://www.hameensanomat.fi/JSP/templates/standardarticle.jsp?version=381>, 13.2.2005)

(16a) *haetuttaa* [fetch-caus-caus] ‘make s.o. fetch, bring’

*6 ja 7 haetutti turhan kauan*

‘6 and 7 **had [me] looking** for them for far too long.’

([http://www.kokkens.net/reitit/03\\_syksy/Oravattonni/kartat/kommentit.txt](http://www.kokkens.net/reitit/03_syksy/Oravattonni/kartat/kommentit.txt), 13.1.2005)

- (16b) *Arvontapalkinto osui Jarmo Karjalaiselle. Ratamestarin merkkauksista huolimatta tuli rastilippujen viejälle yhden lipun valitettava unohdus, joka paikattiin ensi viestien tultua maalille. Puute **haetutti** vähintään parilla minuutilla, joitakin enemmänkin*  
 ‘Despite the markings of the track master, the control point flag carrier experienced an unfortunate lapse of memory that was fixed when the first relays were at the goal. Its absence **kept** [us] **looking** for at least a couple of minutes, some people even more.’  
 (<http://www.paimionrasti.fi/peimari/00/tulokset/030800.html>, 13.1.2005)

Another subject in which CSDs are used is related to army life. In discussions of experiences and opinions of military days, the PMC in particular and bossy causatives reflect the power relationships in the hierarchy relationships of the army. Some CSDs even seem to have become part of army jargon. Examples (17-18) are the motion verb CSDs *hyppyyttää* ‘make s.o. jump’ and *ryömyyttää* ‘make s.o. crawl’. The verb *poistuttaa* ‘to send back/off’ (see 19a-b) evidently derives from the military order *taakse poistu!* ‘move off/back!’. A special case is example (19b), where the expression *taakse poistuttaa* is used as the only Finnish insertion in otherwise Swedish text, functioning as a code-switching element.

- (17) *hyppyyttää* [jump-caus] ‘make s.o. jump’

*Tässä vähän aikaa sitten sattumalta kattoi salareita. Siinähan se yks sankari on suorittamassa asepalvelustaan. Annettiin taas jälkipolville hyvää kuvaa armeijasta. Jos joku ei sattunu kattomaan, niin kerrotakoon että siinä yhessä jaksossa sotilasmestari **hyppyytti** alokasta pitkin iltaa apinaradalla.*

‘A while ago I came across *Salatut elämät* [‘Secret lives’, a Finnish TV series]. The hero was doing his military service. Again there was this great depiction of the army. If you didn’t see it, the episode saw the sergeant major **make** the recruit **do jumps** all night long on the track.’  
 (sfnet.keskustelu.maanpuolustus: Salarit näyttää mallia ja iltikset May 14 2001)

- (18) *ryömyyttää* [crawl-caus-caus] ‘make s.o. crawl’

*Ikuseksi muistoksi jäi mm. se kun hieman siirtymisestä myöhästyttyämme yliluutnantti otti karmeat pultit ja **ryömyytti** koko poppoota alikit ja kokelaat mukaanlukien lumihangessa puolisen tuntia. Siinä malliksi tuleville aliupseereille syvältäjohtamista.*

‘Something I’ll never forget was when the lieutenant got really angry with us for falling behind schedule a bit and **made** the whole crew, including the corporals and cadets, **crawl** through the snow for about

half an hour. There's a perfect model of terrible leadership for NCOs designate.'

(<http://www.yomaa.org/intti/arkisto/000114.html>, 14.2.2008)

- (19a) *Mikäpä siinä olisikaan taakse poistuttaa komppaniamme kantahenkilökunta, aina komppanian päällikköä myöten.*  
 'Why not **move** the regular staff of our company **back** – anyone up to company commander?'

(<http://koti.mbnet.fi/huhtama/sota-pk/army39.htm>, 4.12.2008)

- (19b) *De e nog ganska fittigt onödigt med värnplikt. Men schwebben är inte rätt plats att joma om sånt. Alla tuffa HankOffare blir så lätt sura. Sen taakse poistuttaa dom dig ända till bakre tölö och kallar dig för en fegis.*

'Compulsory military service is quite unnecessary. But *schwebben* is not the right place to grumble about that kind of thing. All those tough officers in the school of economics are so easily ticked off. They **send** you down to Töölö [city district in Helsinki, GP] and call you a coward.'

(<http://www.shsweb.fi/forum/1/192700/>, 4.12.2008)

A term referring to a military power relationship can in turn makes its way into (for instance) discussions about the economy and politics, as with the (*taakse*) *poistuttaa* 'move off/back' order in (20a-b). The adverb *taakse* 'back' can be left out in a sentence with the derivative variant of the command. Note that this order expresses a strong stance towards the exerciser of power.

- (20a) *Katseet voi Perloksen tapauksessa kääntää Nokian ja Mauri Pekkarisen suuntaan – Nokia lyöttää maihin ja poistuttaa ali-hankkijoitaan mielensä mukaan ja Pekkarisen kädet ovat jo valmiiksi pesuvadissa Fortumin jäljiltä.*

'In Perlos' case we can turn our eyes towards Nokia and Mauri Pekkarinen – Nokia fells and **removes** subcontractors as it pleases and Pekkarinen is already champing at the bit after the Fortum case.'

([http://www2.satakunnankansa.fi/blogit/juhaseppala/2007/01/uusiutu\\_vin\\_luonnonvara\\_ei\\_ehdy.html](http://www2.satakunnankansa.fi/blogit/juhaseppala/2007/01/uusiutu_vin_luonnonvara_ei_ehdy.html), 4.12.2008)

- (20b) *Nokian Ollila käskee ja taakse poistuttaa ministereitä.*

'Nokia's (director) Ollila not only orders ministers around, but **gives** them their **marching orders**, too.'

(<http://portti.iltalehti.fi/keskustelu/post!reply.jspa?messageID=8581035>, 4.12.2008)

An area that makes use of *ttA*-causatives with a figurative meaning in relation to bossy causatives is discussions about technology, especially information technology. I will present some examples using the verb *nukettaa* ‘to nuke’ (compare to the examples of *kyykyyttää* ‘make s.o. squat’ in section 5.2.4.2). The writer of example (21a) says how they took delight in crashing a computer. The possessor of the technological knowledge is at the top of the ‘power hierarchy’ in having control over the functioning of the computer system, and the expert enjoys the feeling of power. Example (21b) describes the preparation of food in a microwave oven by ‘nuking’ it with the microwaves. Other IT verbs include those already presented in the previous section, such as *guruttaa*, *warettaa*, *imuttaa* and *googlettaa* (see examples (11)-(12)). It is not unusual for these kinds of technology CSDs to be derived from English root words. However, this is not the case in example (22); the verb *tunnistuttaa* ‘make s.o. recognize’ denotes the function of an antivirus program.

(21a) *nukettaa* [nuke (Eng.)-cause] ‘kill with a nuclear bomb, radiate’

*Päätin heittää pikaisen PR-tempun, valitsin yhden verkon koneista ja **nuketin** sen nurin. Muutamaa sekuntia myöhemmin puhelin soi; toisessa päässä epätoivoinen sihteeri valittaen, että koneen ruutu oli yllättäen muuttunut siniseksi eikä mikään toimi.*

‘I decided to do a quick PR trick: I chose one of the machines in the network and **nuked** it . A few seconds later the telephone rang; at the other end a desperate secretary was complaining that her screen had turned blue and nothing was working.’

(<http://flipperit.net/apz/kirj/index.php?c=lue&t=evvk>, 15.11.2005)

(21b) *Jos on kovin kiire, voi ruokaa **nukettaa** mikrossa ensin kymmenkunta minuuttia, niin paistoaikaa saa lyhennetyksi tovin.*

‘In a rush, the food may be **nuked** in a microwave first for about ten minutes, which shortens the roasting time.’

(<http://biitsi.com/>, 15.11.2005)

(22) *tunnistuttaa* [recognize-caus] ‘make s.o. recognize’

*Ja hyvähän se on että ISP **tunnistuttaa** mailit virusmaileiksi, kuin että itse **tunnistuttaisit** ne, vai?*

‘And it’s a good thing the ISP **recognizes** emails containing viruses instead of you **recognizing** them yourself, isn’t it?’

(<http://sektori.com/aanestys/131?reply=62833>, 8.9.2004 )

It is fascinating to see how lexicon related to consumption has received features reflecting general trends in society. For instance, eating is not simply an act of nurturing one’s body – eating and food compel modern humans to

think about issues like ethics, responsibility and control. The modern relationship to food is quite contradictory: you have to nourish your body, but at the same time the food should be of the right type ecologically, in terms of its nutrition or dietary quality, and furthermore in the right proportions. The demands and emotions related to food and eating are a source of discussion and diarists' reflection. The personal responsibility is to control one's own eating; thus, phenomena like eating disorders, overeating or ethical considerations can create reasoning about the right diet. Often, discussions concerning eating represent soul-searching about the reasons for overeating or undereating or eating the wrong type of food. The Responsibility Shift Construction can be used to identify 'excuses' out of our own control and psychological reasons; eating has actually also happened. The Emotive Causative Construction enables us to leave the reason for eating quite open and simply note the fact that the speaker is thinking about food; the eating itself does not have to take place. Drinking may display similar features to eating, with an even stronger indication of addictive properties, often giving the drinker very little control over the activity. Consider the examples of *syötättää* 'make s.o. eat' in (23a-b) and *juotattaa* 'make s.o. drink' in (24a-b): (23a) is related to the Emotive Causative Construction, (23b) and (24b) to the RSC and (24a) is a productive CSD. Note that example (24a) even has a power misuse indication.

(23a) *syötättää* [eat-caus-caus] 'make s.o. eat'

*Välillä syötättää niin vietävästi ja tulee repsahdeltuakin, mutta koska pidän ruokapäiväkirjaa, niin tiedän ainakin kuinka kauheasti sitä onkaan sorruttu.*

'Sometimes [I] **feel like eating** so badly and I act on it, too, but because I keep a food diary at least I have a record of the dreadful things I've done.'

(<http://www.tohtori.fi/laihduuskeskus/keskustele.php3?min=617>, 7.1.2009)

(23b) *Yleensä se minulla ainakin on tosin päin: väsymys ja ärtymys syötättää.*

'Usually with me it's the other way round: tiredness and frustration **make [me] eat.**

(<http://www.weightbalance.fi/bin/showmessage?ID=1142&Page=70&Language=fin>, 7.1.2009)

(24a) *juotattaa* [drink-caus-caus] 'make s.o. drink'

*Hauskin juhla vuodessa? Äää... Uusvuos ja Juhannus tuli oltua selvinpäin... Sanotaan vaikka hra A:n polttarit, joissa juotatin Juliuksen kaatokänniin ja nauroin itse ilkeänä, ja selvänä, vierestä.*

*Polttarit yleensä.*

‘Best party this year? Erm... New Year and Midsummer passed soberly... Let’s say Mr. A’s stag night, where I **made** Julius **drink** himself stupid and then laughed at him, mean and totally sober. Stag parties in general.’

(<http://kobaia.net/arkisto/2003/10/>, 7.1.2009)

(24b) *Pikemminkin kannattaa miettiä, mitä alkoholismin takana on, mikä juotattaa ja mitä aikoo asialle tehdä.*

‘Rather, one should contemplate what is *behind* the alcoholism: what **makes** one **drink**, and what one intends to do about it.’

(<http://www.yle.fi/mikaeli/arkisto/tutkimus/alkoholismi/>, 7.1.2009)

A broad area that makes use of CSDs is sports. This is not unnatural, as such a setting involves certain social situations. One part of this is the circumstance of real competition between athletes; another involves the ‘wings’ of sports – the relationship between a coach and an athlete, or the team and their sponsor. In sports commentary and discussions, both issues are discussed. The PMC in general, and the defeat construction in particular, are natural expressions in sports contexts. Example (25) contains the verb *hassuttaa*, which can be related to the form *hassutella*, ‘to fool s.o.’. The verb *hassuttaa* is used here in the meaning ‘to fool around; feint’ and it adapts the defeat construction. The verb is presented in the headline of a text commenting on an ice hockey match. Example (26) is a note on a coach’s activity who has the power to keep players on the bench (*penkittää*), which is here seen as a power misuse situation. A CSD can naturally also be used to describe a neutral power relationship in sports, as in example (27).

(25) *hassuttaa* [funny-caus] ‘fool around; feint’

*Hagman **hassutti** Brodeurin* [Headline]

*Hagman teki ratkaisevan maalin rangaistuslaukausten neljännellä kierroksella ja ohitti New Jerseyyn maalivahti Martin Brodeurin näppärällä rystylaukauksellaan /---/*

‘Hagman **fools** Brodeur

Hagman made the decider in the fourth round of penalties and passed New Jersey keeper Martin Brodeur with a dexterous backshot.’

([http://yle.fi/urheilu/lajit/jaakiekko/nhl/2008/10/hagman\\_hassutti\\_brodeurin\\_125516.html](http://yle.fi/urheilu/lajit/jaakiekko/nhl/2008/10/hagman_hassutti_brodeurin_125516.html))

(26) *penkittää* [bench-caus] ‘make a player sit on the bench’

*Uskomatonta, että joukkueella, jolla on varaa **penkittää** Larsson on pakkialustossa noinkin heikkoja pelaajia.*

‘Unbelievable that a team that can afford to **have** Larsson **sit on the**

**bench** has such weak players on its back line.’  
(<http://plaza.fi/muropaketti/bbs/t437513,175>, 23.4.2007)

(27) *otteluttaa* [compete-caus] ‘make s.o. compete or fight (in a match)’

*Kuitenkin mikäli ottelijoille sopii lepoaikaa voidaan lyhentää. Jotta kilpailujen kesto aika ei näistä lepoajoista pitkittyisi voi **otteluttaa** kahta painoluokkaa yhtäaikaan lomittain.*

‘However, if the fighters agree, the rest time could be shortened. So as not to drag out the competitions, two weight classes could **be made to fight** simultaneously.’

(<http://www.judoliitto.fi/database/judoliit.nsf/fbb9ff80acd21284c22569ee002f6994/211637202df54d2c2256e750072cf4f?OpenDocument>, 3.3.2006)

A complex CSD proposition may even receive additional semantic information – some CSDs are used as verbs expressing linguistic communicative actions, often in a blaming or taunting way. Note that the verbs in (28-29) and (31-32) can also be used as bossy causatives. Example (28) describes a verbal competitive situation; *nokittaa* (peck-CAUSE) is here used with the meaning ‘to taunt’. The verb *rökittää* in (29) describes mockery of the SAR, denoting ‘wipe the floor with s.o.’, and *tylyttää* in (30) ‘say harshly’. Examples (31) and (32) express the disapproval of the SAD; *höykyttää* and *kepittää* are used here as ‘to blame, criticize’.

(28) *nokittaa* [peck-caus]

*Toimittajat ovat myös prinsessanherkkiä. Heihin ei kannata suhtautua ylimielisesti tai väheksyvästi. Loukkaantunut toimittaja ei tee hyvää jälkeä. Heikoilla ollaan myös, jos haastattelija ja haastateltava alkavat **nokittaa** toisiaan.*

‘The journalists are as fragile as princesses. Better not treat them contemptuously or sniffily. An insulted journalist doesn’t leave a good impression. You’re in trouble too if the interviewer and the interviewee start **taunting** each other.’

([http://yliopistolainen.helsinki.fi/yol99\\_8/art5.htm](http://yliopistolainen.helsinki.fi/yol99_8/art5.htm))

(29) *rökittää* ‘defeat’

*Toiset pilkkaavat ja kaikkein kovin sanaseppo **rökittää** hänet töissä julkisesti oikein kunnolla.*

‘Some of them mock [him/her] and the toughest wordsmith **strafes** [him/her] at work good and proper.’

(<http://vastaus.net/luku/media2.php?Hae=yes&noma=ext&idkat=6&extdate=1124>)

(30) *tylyttää* [harch-caus] ‘say harshly’

*Miksi sitten ylipäätään pitää jättää? Miksei asioista voi puhua toisen kanssa jo hyvissä ajoin, kertoa ettei kaikki mene niinkuin pitäisi? Onko se sitten niin paljon helpompaa märehtiä itsekseen ja **tylyttää** lopulta asiat päin toisen naamaa?*

‘Why leave? Why didn’t you discuss things with me at the time, tell me things weren’t going right? Is it really easier to mull things over and then eventually **spit** them all in my face?’

(<http://www.city.fi/keskustelut/view.php?id=22613>)

(31) *höykyttää* ‘hammer’

*Oppositio **höykytti** Vanhasta köyhyyspuheesta* [headline]

*Opposition kansanedustajat panivat pääministeri Matti Vanhasen (kesk) torstaina tilille hänen viimeviikkoisesta puheestaan, jossa Vanhanen moitti viestimiä huono- osaisuuden korostamisesta.*

‘Opposition **hammered** Vanhanen over poverty speech

The opposition called Prime Minister Matti Vanhanen to account on Thursday for his speech last week in which he blamed the media for placing too much emphasis on poverty.’

(<http://www.hs.fi/politiikka/artikkeli/Oppositio+h%C3%B6ykytti+Vanhasta+k%C3%B6yhyyspuheesta/1135235280430>)

(32) *kepittää* [stick-caus] ‘beat s.o.’

*Sitten Vihreiden Erkki Pulliainen **kepitti** hallituksen selontekoa siitä, että siinä käsitellään pankkikriisiin liittyvää lähihistoriaa "niukasti ja silkkihansikkain".*

‘Then Erkki Pulliainen from the Green Party **criticized** the government report for handling the recent history of the bank crisis ‘narrowly and with kid gloves’.’

(<http://www.nettisanomat.com/1999/11/18/n9916pankit2arkisto.htm>)

The CSDs thus seem to function either as a neutral (in respect of the power relationship) division of action or as an expression of an affectual aspect of the utterance. The latter is closely related to interpretation constructions, whose communicative effect appears through an expression of attitudes, feelings and prejudices. The affectual effect seems to mutually influence both the genre the CSD appears in and the verb semantics in relation to the situational context. Why are interpretation constructions used? They express, in Austin’s terms, an ‘illocutionary force’ that represents the effect of an utterance such as a threat, a warning or a command (Austin 1962). These constructions epitomize what is done in expressing an utterance. For instance, a PMC expressing disapproval means that the rules



regulating interpersonal relationships are broken. CSD constructions seem to serve different functions, but some of them also overlap. Observations regarding the use of these constructions suggest that a central function is to express **disapproval**. This is the case for instance with the PMC and the responsibility construction of *tapattaa* ‘make s.o. kill’. A reverse function is expressed by the Responsibility Shift Construction i.e. **avoiding potential disapproval**.

The speaker’s purpose can also be seen in the light of its desired effect on the listener. There is an assumption that if the speaker is genuinely aiming for interaction and cooperation, they will try to avoid expressing disapproval (Leiwo 1985: 21). Because, in the case of the PMC, for instance, the speaker is a third party and the disapproval is not directed at the listener, there is in my opinion no direct conflict. This construction creates another specific effect. The examples presented in this chapter indicate that using the PMC may add a provocative character to a message. The affectiveness related to the interpretation constructions is a reason for their use when the speaker’s intention is to add *expressivity* to the message. In this way, the construction seems to be a method for language users to draw attention to their message. The expressive potential can be seen as one of the reasons why CSDs are excellent headline markers as well as discussion verbs. Also, the RSC is a tool of expressivity – if there is a danger of getting the role of the accused, the RSC functions as a means of defence.

However, achieving the affective effect is not the only textual function of CSDs. Derivatives also serve as style expedients. Examples (33-35) show coordinated derivatives using the conjunction *ja* ‘and’. The CSDs here are a repeated element that creates a strong stylistic effect, at the same time supporting the interpretation in question. Example (33) comprises a ‘double’ coordination structure; the CSDs are coupled with their root verbs by the conjunction *kun* ‘when’. Example (34) starts with a provocative question, and then the intensity grows, culminating in coordinated CSDs which, in this expression, have a similar meaning to their root verbs. In example (35) CSDs are used to underline the speaker’s point and to increase the dramatic effect.

- (33) *leikityttää* [play-caus-caus] ‘feel like playing’  
*opituttaa* [learn-caus-caus] ‘feel like learning’

*Lapselle turvataan mahdollisuus leikkiä kun leikityttää ja oppia kun opituttaa.*

‘The child will have the chance to play when they **feel like playing** and learn when they **feel like learning**.’

([http://www.minedu.fi/opm/ministerio/organisaatio/haatainen\\_puheet/lastentarha.html](http://www.minedu.fi/opm/ministerio/organisaatio/haatainen_puheet/lastentarha.html))

- (34) *otattaa* [take-caus] ‘make s.o. take’  
*jätättää* [leave-caus] ‘make s.o. leave’

*Entä mitä löytyy huonosta ja kosiskelevasta lastenteatterista? Oikeastaan ihan samoja aineksia kuin hyvästäkin. Sen lisäksi huono tulee ja esittää, otattaa ja jätättää. Huono ei osaa asettua lapsen tasolle, sellaisen, joka sylivauvanakin rakastaa loruja, hypytyksiä, taputuksia ja loputonta toistoa.*

‘And what is found in bad children’s theatre? Actually, the same things as in a good one. The bad one comes in, does its things, **takes** and **leaves**. It doesn’t know how to bring itself down to the level of children, who love rhymes, jumping around, clapping along and endless repetition.’

([http://www.kajaaninteatteri.fi/ohjelmisto/kritiikki.php?naytelma\\_id=lorulot](http://www.kajaaninteatteri.fi/ohjelmisto/kritiikki.php?naytelma_id=lorulot))

- (35) *makuuttaa* [lie-caus] ‘have oneself lain in bed’  
*nostatuttaa* [lift-caus-caus] ‘make s.o. lift’  
*vaipotuttaa* [diaper-caus-caus] ‘put in a diaper’  
*pakkosyötättyää* [compulsion.eat-caus-caus-caus] ‘make s.o. feel compelled to eat’

*Sanotaan nyt tuo vielä kerran; jokaisella on oikeus makuutta ja nostatuttaa, pakkosyötättyää ja vaipotuttaa itseään täysin autettuna vaikkapa ikijäähän asti*

‘Let’s say this one more time: everybody has the right to make [the nurses] let [them] lie in bed and lift [them], let [them] **make** [them] **eat** and put them in diapers completely assisted until the permafrost sets in.’

(<http://www.lansivayla.fi/lansivayla/discussion.php?item=20882&t=1081845289>, 20.12.2004)

Stylistically, Finnish verb derivation without a doubt provides a rich idiomatic means of cultivating playful and creative language use. Part of the reason for the use of verb suffixes instead of analytic verb bonds is the chance to modify the root word’s meaning in a dexterous and expressive way. Examples (36-37) from the evening newspaper *Ilta-sanomat* illustrate this. Example (36) reports on the doings of the somewhat eccentric wife of a pig farmer, an art collector and actor known as Madame E, alias Eila Lemmelä<sup>63</sup>. The verb *otatella* is a combination of the causative suffix *ttA* and frequentative suffix *ele* with the root verb *ottaa* ‘to take’; the frequentative meaning component adds the implication that it should not be taken too seriously. Example (37) uses a laid-back, humorous style, with an almost

<sup>63</sup> This information is taken from the Film Catalogue website <http://www.filmkontakt.dk/showroom/da/?id=4&movieid=1389>, 25.2.2008).

indiscernible irony, to describe a visit by a TV licence controller. There are two *ttA*-causatives in this example: one of them, *pyyhittää* ‘make s.o. dust’, encodes the SAR as an instrument, while the other, *kuunteluttaa* ‘make s.o. listen’, is an agent.

(36) *otatella* [take-caus-fre]

*Eila Lemmelä otattelee rooleja, jottei arki olisi ikävystyttävää.*  
 ‘Eila Lemmelä **takes** roles so as to avoid the tedium of the week.’  
 (*Ilta-sanomat* 24.11.2004)

(37) *pyyhittää* [dust-caus] ‘make s.o. dust’  
*kuunteluttaa* [listen-caus] ‘make s.o. listen’

*Kun sitten lupatarkastaja tulee, hänet pitää roudata huoneisiin saakka, tsekata komerot ja tonkia kalusteet, **pyyhittää** hänellä pölyt, tarjota kaffet, kertoa kylän juorut, lukea päivän lehdet, **kuunteluttaa** vähän radiota, /---/ kertoa oma arpihistoria, ja näin todistaa, että elämää ilman televisiota on olemassa.*

‘When the licence controller comes, he has to be hauled upstairs to check the closets and furniture, [he has to be] **dusted** the places with, offered coffee, let in on the village gossip, read the day’s papers, **allowed to listen** to the radio for a while, /---/ have all of one’s cicatrice history recited to him, just to prove that there is life without television.’  
 (*Ilta-sanomat* 9.3.2005)

The preliminary observations about the genre functions of CSDs can thus be summarised as that verb semantics are generally influenced by the situation in which they are used. CSD constructions set their own restrictions on the verbs and genres with and in which they can be used. For instance, the PMC and responsible SAR constructions appear as headline lexica, in newspaper texts generally, and also in discussions. The Responsibility Shift Construction and Perceptual Causative Construction are found in narrative diary genres, such as discussions and blogs. A common factor of the interpretation constructions is their expressivity attribute arising from the illocutionary force. The study of derivatives can thus be extended to larger language units. From the discussion above we get at least the following topics for future research: How does a text type emerge? What is the textual function of CSD expressions? How are responsibility shift and reproach expressed across languages?

## 6. Conclusion

In this study I have investigated derivative verbs and their lexical relationships. The basis of this examination has been Finnish causative verbs denoting social dominance (CSD), derived with the suffix *(U)ttA*. The objectives of this study can be generalised as two questions, closely related to the essential nature of the topic: how does word derivation function? And what is the nature of social causation? When it comes to the first question, I seek to clarify how causative derivatives relate to one another and how lexical verb groupings take form. Is there a cohesive force, a shared characteristic or structure uniting the derived verbs? What kind of relationship is there between the root word and the derivative? The second research question is related to the characteristic semantic feature of these verbs: CSDs typically refer to a situation where one person, via interaction, impels another person to act. Hence CSDs provide an opportunity to examine how social relationships are encoded in language. In order to capture the derivational phenomena and the social dimension involved, the research questions are approached by combining both information from language use and a formal description.

I have argued against the assumption that causative derivatives are a syntactic transformational rule. In view of the classification of derivatives, criteria based directly on the root verb and the morpheme characteristics do not necessarily describe the actual behaviour of the derivatives. Therefore, it has been necessary to broaden the perspective on verb derivation from the morphosyntactic premise to lexical dynamics. The results of this study support the lexicalist hypothesis of Chomsky (1970), which assumes that word derivation does not take place in syntax but in the lexicon (the lexicalist hypothesis is revised in Chomsky 1995). In other words, I do not assume that causatives are formed syntactically (for the lexical syntax view, see e.g. Halle & Marantz 1993). Derivation does not function without gaps, and derivatives should therefore be treated as independent lexemes with particular mappings to phonological, syntactic and semantic information.

Alongside the consideration involving questions of word formation and lexical processes, it has been necessary to adopt a view concerning diverse phenomena closely related to morphological causatives. When analysing CSDs, it has been necessary to discuss such traditional grammatical notions as transitivity, agentivity, causation and prototypes. The examination of this study departs from the general characteristics of CSDs to constructional grounds, thus also concerning the theory of constructions. The nature of constructions is discussed in connection with a special type of construction, introduced as the interpretation construction, concerning the relationship between language and interaction along with the foundation of social conceptualisation. In connection with CSDs the study also deals with

constructions of more traditional types (Fillmore 1975 & 1985; Kay 1990; Goldberg 1995, Fried & Östman 2004).

The starting point for this study was the derivational group of deverbal verbs traditionally classified as curative causatives (Cannelin 1931, Penttilä 1963, Siro 1964 & 1996, Hakulinen & Karlsson 1979, Kytömäki 1978 and ISK 2004). This verb group proved to be not as clear-cut as proposed in earlier research. The range of variation in the syntactic and semantic behaviour of causatives in relation to their root verb properties suggests that these derivatives have an individual lexical structure and that the traditional criteria used to define curative causatives are problematic (the criteria applied to define curatives are discussed in detail in section 1.2). The analysis in this study indicates that in actual cases, the criteria of prototypical curative causatives partly overlap, and the notion of a derivative verb class based on morphosyntactic criteria does not entirely explain the behaviour of these verbs.

The derivative process forming curatives is based on the expectation that by adding the *ttA*-morpheme to a transitive verb, the derivative entails an extra causer and an adjunct marked with the adessive case. Since this study comprises verbs extending from traditional curatives, including causatives derived from different types of root verbs and even some *ttA*-causatives derived from nouns, I use the term **causatives of social dominance (CSDs)**. I refer to the two basic classification traditions of the curative causatives as the morphosyntactic view and the morphosyntactic-semantic view. The notion of curative causatives thus functions as the starting point for the contemplation of linguistic categorization. The transitivity criterion of the root verb as the requirement for a derivative to enter this verb group is contemplated here on several occasions. The status of transitivity as a lexical property has been shown in this study to be problematic, because transitivity cannot be regarded as a constant quality of the verbs. This is the conclusion of the syntactic analysis of CSDs as well as the constructional phenomena related to CSDs. The discussion in this study indicates that verb transitivity is rather a prototypical notion related to the sentential level explaining the possible types of syntactic environments in which the verb may occur.

While the morphosyntactic approach only classifies causatives derived from transitive root verbs as curatives, representing the 'ideal' curative causative as a result of the syntactic process, the morphosyntactic-semantic approach is more flexible in its categorization of the curative causatives, taking into consideration the large variety of verbs within transitives and intransitives. The morphosyntactic-semantic approach emphasises the notion of the activity of the root verb and the non-participation of the subject argument of the derivative in the activity denoted by the root verb. These features were found to encapsulate an essential aspect of the information encoded by these derivatives; however, it was also inferred that it is not beneficial to add these features directly to syntactic criteria or to root verb

---

requirements. I therefore argue that in order to keep syntax as straightforward as possible, transitivity should be analysed at a separate, syntactic level in respect of the semantic description of verbs; at least a satisfactory account of verb classification cannot be based on the transitivity criterion. The description of the semantic properties of CSDs should be identified in a more precise way in connection to the derivatives. The syntactic analysis of CSDs derived from various types of root verbs in chapter 3 in particular can be seen as a test of the morphosyntactic approach. The semantic criteria of CSDs are involved in particular in the conceptual structure analysis of this study, discussed in detail in chapters 4 and 5.

Causatives of social dominance are an excellent topic for examining both causation and social representation. I have approached these phenomena from different viewpoints. The emphasis on the one hand is on the lexical description of the verbs, and on the other on usage-based analysis. The materials were collected from the Internet and the Finnish Language Text Collection *Kielipankki*. Data from language use allows us to study the verbs in context, and this has revealed new aspects of the behaviour and lexical properties of CSDs and more broadly of word formation and lexical groupings. The Internet material in particular has indicated a large range of stylistic and, above all, situational contexts in which CSDs can be used.

This study aims to present an exact formal description of the observations. In order to integrate information from different levels, we need a strict semantic description of the lexemes and the morpho-syntactic processes. The theoretical framework and basis for the semantic analysis in this study is the conceptual semantics theory and its methodology. Methodologically, the description of the lexical conceptual structure enables us to include the contextual information in an explicit way. Another goal of this work is to integrate the generalisations of the nature of social causation into the established language description. The discussion in chapter 2 introduces the basic ideas and methods of conceptual semantics; these are then adopted in the actual analysis of the subsequent chapters.

One of the basic ideas of conceptual semantics is that the syntactic and semantic properties of linguistic phenomena are approached on separate levels. The semantic characteristic of verbs is described via their conceptual structure – a level of understanding linguistic information and a link between linguistic representations such as phonology and syntax and other cognitive domains (spatial, social, haptic knowledge etc.) (Jackendoff 1983 & 1990; Nikanne 1990 & 2008). In the conceptual structure analysis, I have focused on the thematic structure, the action tier level and the temporal tier of CSDs. The formalism of conceptual semantics provides a theory for the notions of ‘causation’ (expressed on the thematic tier) and ‘activity’ (described on the action tier level) separately. This implies, among other things, that action does not automatically equal causation.

Another objective of this study was thus to elucidate the nature of linking between the linguistic and conceptual structures of CSDs. The relationship from syntax to conceptual structure is not assumed to display a one-to-one correspondence; therefore, for the analysis of deverbal causatives, a determination of the intermediate linking level is useful in order to distinguish the particular linking relationships. I included the morpholexical level and morphoroles (introduced in section 2.2.2) in the analysis for an accurate mapping of the root verb arguments as a description of syntactic and conceptual levels. As such, for a more detailed account of root verb arguments, this analysis of causatives operates with the morphoroles **SAD** (the subject argument of the derivative), **SAR** (the subject argument of the root verb), **OAR** (the object argument of the root verb) and **ORadj** (the optional object or the adjunct of the root verb in the object position) in the analysis of causatives. The morpholexical level thus functions as an additional intermediate linking level besides the direct argument level (the DA system) that determines the subject argument and object argument among the conceptual arguments. In the actual analysis, the morphoroles proved to be a feasible means of explication of the mapping relations of the selected CSDs from the conceptual structure to syntax. Hence the involvement of the morpholexical arguments in the description of causation and activity is visible in their linking to the conceptual structure.

The syntactic structure of CSDs and the effect of the root verb on the derivative were examined in chapter 4. This analysis primarily comprised the level of morphoroles, syntax and the thematic tier. Furthermore, the linking relations between the morphosyntactic and conceptual representation were accounted for. The status of the morphoroles was approached from two perspectives: their mapping to the conceptual level; and in relation to the DA level. The result was that morphoroles have a somewhat different status in terms of these levels: the SAR has a higher position in the thematic tier, but the OAR is higher in the DA2 linking hierarchy. The language instinct test of comprehension of CSD sentences discussed in section 3.1.4 enlightens the argument structure and the morphosyntactic behaviour of CSDs as well as the syntax-semantics interface of these verbs. With a view to future research I would highlight the contribution of the language instinct test, which raises new questions about language use and the intuition of language users. How does language instinct operate? What is lexically encoded information? What is the role of context, and what leads to certain interpretations? Why are certain argument structures ambiguous?

The discussion in chapter 4 is basically a conceptual semantic analysis of the essential semantic properties of the curative causatives proposed by Kytömäki (1978), referred to as the activity criterion and the non-participation criterion in section 1.2. The activity of the SAR is regarded as part of agentive features, described on the action tier level; the participation of the SAR in the activity is in turn dependent on the temporal characteristic

of the causation(s) involved in the CSD proposition. The CSDs were thus approached in chapter 4 from two points of view. Firstly, the agent properties of the main human arguments, the SAD and the SAR, were discussed. It was shown that the agent properties are not distributed completely equally between the actors of the CSD prototypes. Depending on the number of causations in the conceptual structure of a CSD, the SAR was separated into two types: the causer-SAR and the theme-SAR. As a point of comparison, the proto-agent properties defined by Dowty (1991: 571-575) were used. In terms of the present methodology, the Dowtian agent features are divided between different levels in the conceptual structure; instead of a list of features, the semantic description of a complex CSD situation is expressed as an interplay between different levels of description. The motion and causation features are stipulated in the thematic tier. The properties related to the control, volitionality and consciousness of an agent are analysed as (primary or privative) semantic features, added to functions where needed. Aspectual parameters such as directional and bound nature in turn form part of the thematic feature systems analysed further under semantic functions (cf. the methodology of conceptual semantics in section 2.2.1). Instigating and performing features are closely connected to the temporal structure of the LCS. This section showed that in addition to the SAD, the SAR-actors are strong agents, especially the causer-SAR. All of the agents involved were found to include proto-patient features (see section 4.2).

The second approach to causation in chapter 4 was a study of temporal relations by analysing the temporal tier. As mentioned above, this is the level affecting the agentive features of instigating and performing. The internal temporal structure of causation events was analysed as two types according to the models of Jackendoff (1990) and Nikanne (1990): entrainment causative events, describing causation that lasts as long as the caused event does; and launching events, causation that is related only to the starting point of the caused event. The study of the temporal tier reveals that the first causation is a launching event when the SAD does not take part in the action denoted by the root verb. Hence the temporal type of causation is closely connected to the question of whether the SAD takes part in the event encoded by the root verb. When it comes to participation, the type of activity in respect of the activity denoted by the root verb is not always significant (the activity of the SAR is not necessarily equal to the sense of the root verb). It also appeared that both double-causative and single-causative prototype verbs could have launching and entrainment readings. The agent properties of the CSD actors in an actual situation thus influence the verb's temporal reading: when the first causation is launching, the actor assigned by its argument (the SAD) is an instigator; when the causation is entrainment, the actor assigned by the SAD is not necessarily the performer of the root verb activity, but participates in the event in some way.



In section 4.3.5 the causation analysis was extended from the core CSD sentence to causative subordinate structures. The combination of temporal tier and subordinate causative structures clarified the causative relationship within complex sentences with causative and temporal elements spread between conceptual elements. As a result of the analysis, the relationship between the subordinate causative and the matrix structure is divided into two types:

**LEAD TO** – the matrix sentence causes the situation denoted by the adjunct, as in the effect on the adjunct structure *ykkösvahdin paikasta* ‘for the position of first keeper’ in:

*Benitez ottelutti maalivahteja ykkösvahdin paikasta*  
 Benitez compete-caus-past-3sg first.keeper-gen place-ela  
 ‘Benitez had the goalkeepers **compete** (in a match) for the position of first keeper’

**BECAUSE OF** – the adjunct structure causes the situation expressed in the matrix sentence, as in the causing effect of the adjunct structure *töräytyksillä* ‘the slurs’ in:

*Lue, millä töräytyksillä Idols-tuomarit itkettivät tänä vuonna kilpailijoita*  
 read, what-ade slur-pl-ade Idols.judge-nom-pl weep-caus-past-3pl  
 this-ess year-ess contestant-part-pl  
 ‘Read about the slurs the Idols-judges came out this year to **make** the contestants **cry**’

The metatheoretical contemplation in chapter 2 was based on the nature of the categories used within linguistics in the light of word formation. How successfully do the notions of different types describe the nature of derivation? Is it methodologically more convenient to assume the linguistic categories to be classic or prototypical? My hypothesis is that the notion of ‘prototype’ is a useful concept when describing the inner dynamics of a heterogeneous derivative group. In contrast, the clear-cut features and their combination principles that e.g. conceptual semantics methodology operates within can be used in the identification of the grades of the continuum of the examined entities. Thus, the actual analysis of the lexical and contextual information in this study can be seen as an attempt to unify these basic categorical concepts. In order to identify the combinatorial variation between lexical entries that gives ground for graded relationships within a lexically related group, I have combined an essentially componential semantic analysis with the theory of prototypes and gradual categories.

How is the clear-cut and gradual nature of derivatives taken into consideration? The methodological basis of analysis is structured around classical categories: syntactic and semantic properties of CSDs are analysed on separate levels, both of them with their own primitives. These primitives are considered to be clear-cut categories. Graduality appears through instantiations of patterns of syntactic and semantic combinations. The prototype in this study is seen to be a combination of (combinatorial) primitives, a template of reduced structure behind the derivatives typifying independent lexical units with certain common features. It represents the abstract type of prototype, the conceptual core that the structures of single verbs can be compared to. Basically, formal analysis of the prototype structures of CSDs aims to define the abbreviations between patterns with shared structural elements. In other words, the idea behind prototype analysis is that by defining the constant and variable features, we can detect the prototypical and non-prototypical combinations of primitives.

Throughout this study, the goal of the verb analysis has been to identify the prototype structures of CSDs and to contrast the defined patterns with actual cases. The basis for the analysis of CSD prototypes is the lexical conceptual structure and the linking system comprising the DA and morpholexical levels. The linking organization illustrates the mapping between the conceptual and syntactic structures. The prototype patterns of CSDs are defined in section 3.4 as the result of the syntactic and conceptual structure analysis of the selected causatives of root verbs with varied transitivity values (specifying the first outline of the prototypes given in section 2.4.2). These verbs were tested in different sentential contexts from two viewpoints: firstly, the acceptability of the sentences was tested on language users in the form of a language instinct test; and secondly, the conceptual structure of the sentences was analyzed. It appeared that the crucial aspects of the CSDs were the linking of the SAR (subject of the root verb) and the social type of causation. The shared properties of the studied CSDs are defined in (1), depicting the core of different CSD structures, such as the prototypical core. Note that the angles brackets < > around the implicitness marker, index I, indicate that the argument linked to the SAR is optionally implicit or explicit. The action tier function AC marks the role actor, meaning that this argument is an active participant.

## (1) Core of CSD prototypes (PT):

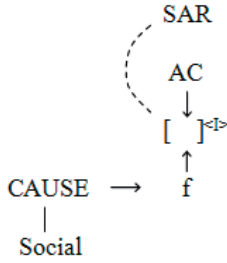

In the present approach to causative verbs, which can be called the prototype-constructional view, I have made the distinction between the two main prototype structures based on the linking regularities of CSDs, presented in 2a and 2b:

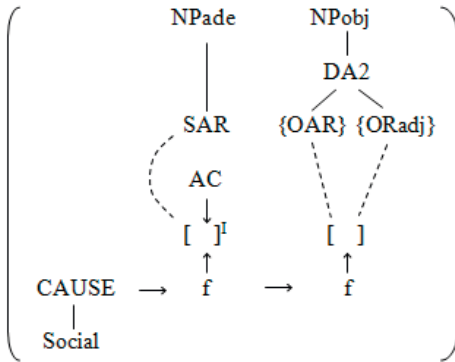
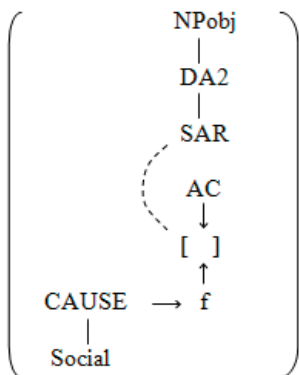
2a) Adessive adjunct-actor prototype **PT1**:b) Objective actor prototype **PT2**:

In both PT1 and PT2, the second argument, the SAR, is an active participant (actor on the action tier level). The main distinction between the prototypes is the linking of the SAR: in PT1, the SAR appears as the adessive adjunct, while in PT2 the SAR assigns the object function. Within PT1 and PT2, further structures are separated and analyzed as subprototypes PT1.1, PT1.2, PT2.1 and PT2.2 based on f-chain linking (the analyses of these structures are given in section 4.4). Characteristic of these subprototypes is the fact that the SAR may or may not be a causer. Compared to PT1 and PT2, the formal description of the further subprototypes breaks up the optionality indicators as angled brackets and the bare notion *f* (identified as an f2 or f3 function in the more detailed descriptions). The following examples illustrate the subprototypes: the sentences with the CSD *ompeluttaa* ‘make s.o. sew’ in (3a) and (3c) represent causer-SAR structures, and the CSD *juoksuttaa* ‘make s.o. run’ non-causer-SAR structures. Note that PT1.1 represents the morphosyntactic notion of curative causatives, a double causative derivative with the adessive adjunct.

(3a) Example corresponding to PT1.1

*Matti ompeluttaa Pekalla puvun*  
 Matti sew-caus-pres-3sg Pekka-ade dress-acc  
 ‘Matti makes Pekka sew a dress.’

(3b) Example corresponding to PT1.2

*Matti juoksuttaa Pekalla lenkin*  
 Matti run-caus-pres-3sg Pekka-ade run-acc  
 ‘Matti makes Pekka go for a run.’

(3c) Example corresponding to PT2.1

*Matti ompeluttaa Pekkaa*  
 Matti sew-caus-pres-3sg Pekka-part  
 ‘Matti had Pekka sew.’

(3d) Example corresponding to PT2.2

*Matti juoksuttaa Pekkaa*  
 Matti run-caus-pres-3sg Pekka-part  
 ‘Matti makes Pekka run.’

The crucial outcome of chapter 3 was that regardless of the syntactic characteristics of the root verb of a CSD, the derivative can, in principle, be associated with both PT1 and PT2 patterns. This implies that CSDs cannot be divided into different groups according to prototypes i.e. into PT1 and PT2 verbs. Another implication is that the adessive adjunct-actor pattern is not a consequence of double-causative CSDs: the adessive SAR can be linked to both an f3 and f2 function (this is also the basis for the further division of

PT1). The causation-based prototypes, PT1.1 (the adessive adjunct prototype of a double-causative) and PT2.2 (the objective actor prototype of a single-causative), proved useful as models in the study of action tier configurations and the temporal analysis of CSDs in chapter 4.

As such, the PT1 structure generally functions in connection with different types of verbs irrespective of their degree of transitivity. There may be arguments for the linking arrangement of the SAR in the adessive case being a specific syntactic-conceptual linking configuration, a constructional pattern rather than a lexical property of some CSDs (those derived from the transitive root verbs). Does this special type of argument-linking configuration correspond to the traditional definition of construction, a particular form-meaning constellation independent of lexical items that instantiates them in the sense of Fillmore (1975 & 1985), Kay (1990) and Fried & Östman (2005)? In a sense, a PT1 proposition functions in a similar way to the resultative construction – in order to license the SARade, there has to be an object or an object-like constituent. As the language instinct test in section 3.1.4 indicated, when this type of sentence lacks an object argument, for instance, the locative function of the adessive case is activated. In this study, I have argued against the traditional view that there is a curative causative verb group. Instead, there is a prototype, the PT1 that licenses the curative interpretation. I treat the PT1 basically as one of the main prototype structures in which CSDs can occur; it can be seen as a default pattern besides the PT2. The PT1 functions as a regular linking configuration common to most CSDs and represents a pattern structure to which CSD structures are compared.

In this study, constructions are regarded as patterns which do not match the prototypes in some respects. Following the line of conceptual semantics, I assume that there are productive, regular rules in language as well as exceptional phenomena (Nikanne 2005 & 2008; Pörn 2004). Based on this approach, the exceptional rules describe the constructional patterns and refer to particular linking configurations regarding syntactic, semantic, morphological or lexical categories. I thus argue that the prototypes represent the general nature of CSDs while the more particular structural mappings represent constructional patterns.

The route of analysis in this study of CSDs begins with a description of the regular rules and then examines irregular phenomena. The data from language use has disclosed some deviations from the prototype structures. The variations may be related to the dominance relationship between the participants or to the nuances of the semantic field of social causation. Consider in this light examples (4a-c), illustrating idiosyncrasy in the dominance relationship (these examples were discussed in section 5.2.3):

(4a) *juoksuttaa* [run-caus] ‘make s.o. run’

*Miten reagoit, jos säyseästä ja hymyilevästä naisesta tuleekin kiukkupussi, joka juoksuttaa sinua vähän väliä asioillaan ja itkee usein?*

‘How would you react if a shy, smiling woman turned into a furious monster who **was running** you **around** the whole time with her business and often crying?’

([http://www.soneraplaza.fi/ellit/artikkeli/0,2705,h-2091\\_a-0869,00.html](http://www.soneraplaza.fi/ellit/artikkeli/0,2705,h-2091_a-0869,00.html), 30.8.2005)

(4b) *pyörittää* [spin-caus] ‘make s.o. spin’

*Tytöt osaavat pyörittää isäänsä kyllä ostamaan kaikenlaista pehmolelua, tiimarikamaa sun muuta.*

‘The girls know how to **wrap** their father **round their little fingers** (spin him around) to buy them all kinds of cuddly toys, knick-knacks and things like that.’

(<http://www.eroperhe.net/keskustelu/index.php?topic=14755.0>, 30.8.2005)

(4c) *kyykyttää* [squat-caus] ‘make s.o. squat’

*Vallan harvinaista ei ole sekään, että keskijohto pönkittää asemaansa kyykyttämällä alaisia. Etätyöntekijää on vaikeata kyykyttää, ja silloin esimies tuntee oman asemansa uhatuksi. Siinä yksi syy, miksi etätyö etenee jähmeästi. (Kielipankki: kesu 1999)*

‘It is not unheard of for central management to shore up its position **by snookering** subordinates. It is difficult to snooker telecommuters; the boss then feels that his pitch is threatened.’

The conceptual structure of these examples is analysed in (5) below; because of the particular dominance relationship between the participants, I call it the Power Misuse Construction. The notation UN- in the formal description stands for the malefactive, a subrole of the undergoer, meaning that the activity of the actor in this action tier has a negative effect on the argument linked to this undergoer (the SAR).

## (5) Power Misuse Construction (PMC)

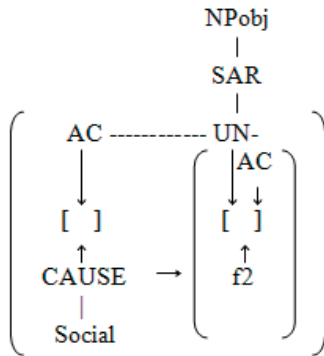

Another particular pattern of social dominance appears in examples (6a-b), analyzed in (7). The essential characteristic in this case is that a stimulus on the mental level (the disappointment in (6a)) has the power to control the SAR's activity, even moreso; this power is explicitly transferred away from the SAR (the eater or drinker in (6a-b)) in this proposition. The fact that the SAR is at the same time the only +human participant capable of consciousness involved in this proposition strengthens the control transition reading. Therefore, I call this construction the Responsibility Shift Construction. Note that in the formal description of the construction in (7) the type of causation is expressed by the psychophysical semantic field, defined as a subfield of social causation in section 5.3.1 (discussed also in 5.4).

(6a) *syötättää* [eat-caus-caus] 'make s.o. eat'

*Varsinkin varhainen hylätyksi tulemisen kokemus tuo sisällemme syöjättären. Se on olemisen malli, jossa ratkaistaan piilotajuisia ongelmia syömällä. Sisällämme oleva pettymys **syötättää** meitä.*  
 'Early experience of abandonment in particular awakens the eater in us. It is a model of existence where subconscious problems are solved by eating. Inner disappointment **makes** us **eat**.'  
 (<http://users.kymp.net/olmoi/paa/kurssi/kurssiku.html>, 22.3.2006)

(6b) *juotattaa* [drink-caus-caus] 'make s.o. drink'

*Mitä enemmän pyrimme tälle hengelliselle tielle, sitä enemmän Paholainen tarrasi kiinni. Se **juotatti** kahta kauheammin!*  
 'The more we tried to achieve this spiritual way, the more the Devil got hold of [us]. This **made** [us] **drink** twice as much!  
 (<http://www.rukousystavat.fi/mparan.html>, 7.01.2009)

## (7) Responsibility Shift Construction (RSC)

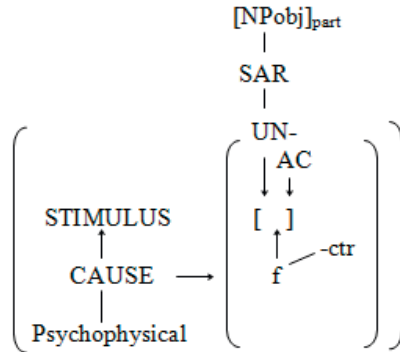

The aspects important to social conceptualisation and power relationships are closely connected to the human participants and their relationship expressed in the linguistic utterance. The relevant properties of the participants involved in a **power misuse event** (expressed by sentences (4a-c)) are thus the following: the SAD controls the activity of the SAR and misuses its power position in respect to the SAR (at least from the speaker's perspective). The SAR is an active (assigning both the roles actor and malefactive) theme whose activity is humiliating and often done in vain. The lexicalised negative dominance is thus the crucial characteristic of the Power Misuse Construction. The SAR of the Responsibility Shift Construction is not acting under an active SAD's dominance. The essential property of the **responsibility removal event** (sentences (6a-b)) is the control shift from the SAR to the non-active SAD. The changed cognitive background of the causation is in this case expressed by the psychophysical semantic field. For these constructions, the properties of SAR are thus central. What is common to the PMC and the RSC is that they do not encode 'joint intention' in Jackendoff's (2007:173) terms as the CSDs in a prototypical case do.

How does the negative effect on the SAR appear? Language use examples reveal that the SAR is not necessarily aware of the misuse situation. The constructions mentioned above, the PMC and the RSC, license the interpretation of a verb as part of the construction if the context strengthens the interpretation. Both the PMC and RSC have a special connection to the context and communicative situation; therefore, I have concluded that these constructions are **interpretation constructions** (see chapter 5). The 'look of reproach' in the case of the power misuse event is not necessarily directed towards the participants in the linguistic utterance, but towards the situation in which the power is misused. The observer and interpreter is the speaker, whose judgment of the power abuse situation is stated; thus, the communicative situation forms an important part of the meaning. The



speaker expressing the RSC transfers power in the form of control and responsibility from the participant normally accountable for the activity. The result is the proposition that it is not the SAR's fault that they are carrying out the activity expressed by the root. The SAR performs a self-harming action (eating) but cannot be held responsible for it.

Hence the speaker's perspective on the PMC situation is at the same time the *interpretation* of it, based on their experience and recognition that the SAD is misusing its power. This construal includes information on social dimensions like dominance and causation and additionally an attitude towards the described situation. Disapproval is a particularity of this construction; it does not follow directly from the verb, but from the interface between verb and interactional context. The identification of this special kind of construction as an interpretive construction is based on an assessment and conventionalized interpretation of the situation expressed by a proposition. A property of the interpretative construction is that the contextual reading is a precondition for the possibility of occurrence of such a construction. Thus, here we have to work with an interface construction. There may be a range of conventionalized interpretative implications from which the language user selects the most appropriate. From this perspective, the Emotive Causative Construction (Fin. *tunnekausatiivikehys*, see Siirinen 2001; Pörn 2004, discussed in section 5.3.1) with the experiencer linked to the syntactical object, can on a broader level also be seen as an interpretive construction. An example of an Emotive Causative Construction with two CSDs is (8):

- (8) *syötättää* [eat-caus-caus] 'make s.o. eat'  
*juotattaa* [drink-caus-caus] 'make s.o. drink'

*Itseni tuntien minua varmasti syötättää ja juotattaa koko illan*  
 'Knowing me, I will undoubtedly **feel like eating** and **drinking** all night.'

What are the essential aspects of an evaluative construction? The interpretation constructions discussed in chapter 5 indicate that CSDs can be used in different ways in respect of the prototypes. The interpretation of these verbs partly depends on their root verb properties, but the essential aspect is that the interpretation constructions add pragmatic information to the expression. By a fixed structural form like the PMC, the construction is activated and the negative domination interpretation from one participant towards another is launched. The discussion in section 5.2.3 indicates that CSDs derived from motion verbs in particular have a probability of triggering the power abuse construction. The social conceptualisation hence comprises aspects of the power relationship. With the PMC, there are several contextual cues that lead to the constructional reading. Firstly, there is a reference to a social hierarchy. Secondly, the following features of the malefactive SAR affect the reading: the SAR's activity has no purpose, it can be repeated, and

typically the SAR is not aware of misuse. From these aspects arises the accusatory attitude, which strengthens the PMC reading.

In addition to the interpretation construction involving pragmatic evaluative implications for the expressed situation, there are also lexical constructions in connection with CSDs, such as the lexical particularity *tapattaa* ‘make s.o. kill’ discussed in sections 4.3.6 and 5.3.3. There are distinctive patterns of dominance relationships and characters of causation in both kinds of constructions. The argument structure of the verb *tapattaa* does not appear to completely correspond to the prototype structures of CSDs; consider (9) below:

- (9) *Kenraali tapatti sotilaitaan rintamalla*  
 general kill-caus-past-3sg soldier-pl-part-px3sg front-adessive  
 ‘The general got his soldiers killed on the front.’

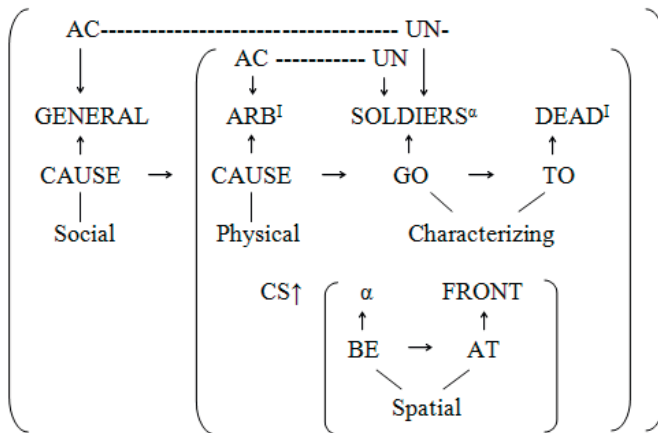

The linguistic form of the construction consists of the object and a PP or adverb that expresses location, as in (8). The causation relations in (8) are exceptional in that the first causer (the general) is not intentionally forcing a second agent to kill the soldiers. The locative phrase ‘on the front’ adds a causative effect to the proposition by expressing the causing event. Thus, the general is not making anyone kill the soldiers, as it is undoubtedly the enemy that is doing this, and the general has not asked or forced them to do so. However, the general is held *responsible* for the death of his soldiers – he made a wrong decision or is just irresponsible. The locative phrase, ‘on the front’, expresses the causing event and refers to the place and the circumstances in which the soldiers are killed.

The Perceptual Causative Construction discussed in connection with *haetuttaa* ‘make s.o. fetch’ and *etsityttää* ‘make s.o. search, seek’ in section 5.3.4 turns the semantic field of causation into a psychosocial one and

includes the parameter of success (Jackendoff (1990: 130-133)) in the causation, depending on the outcome of the causation. In (10), the causation does not have any effect:

- (10) *Telttapaikka haetuttaa itseään*  
 tent.space fetch-caus-pres-3sg self-part-px3sg  
 ‘The camping area [gets you looking] for it.’

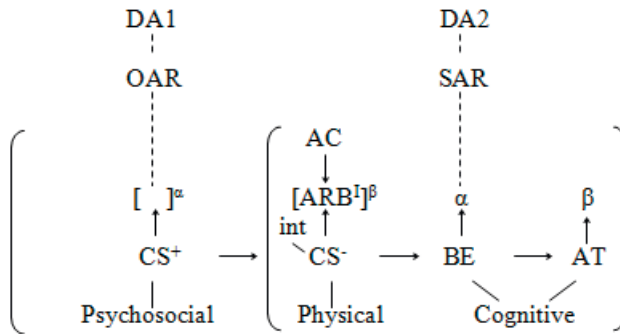

The notion of prototype represents an abstract categorization, a semantic-morphological template with which the verbs can be compared, not a form of regular compositional word formation. This does not have the same mandatory power as e.g. the notion of base form. It is seen as the connective force that gives the verbs licence to be a member of a group. Thus, the prototype idea is a possible way of approaching verb groupings. The discussion of CSD constructions and the verbs associated with them suggests that in addition to regular linking, which corresponds to the prototype structure, there are constructions that in some cases build related patterns that contribute to the verb grouping arrangement. In other words, CSD constructions also have an effect on lexical relationships among *ttA*-verbs. The constructional patterns have an effect based on analogical relationships, attracting existing lexemes to behave within the limitations of the construction. As such, for a more precise description of CSDs it is essential to also take into account the possible constructions in which they may participate.

An outcome of chapter 5 was that CSD constructions too may be related to each other and form constructional networks within a construction family i.e. constructions that are related but convey their own nuances (for constructional networks, see Fillmore 1999, Goldberg 1995; the notion of construction family is introduced by Björklund, Nikanne and Virtanen 2003). The PMC was found to comprise associative subconstructions with the *ttA*-suffix and the special power relationship between the participants as common features (see the discussion of PMC subconstructions in section 5.2.5). The

research results of this study indicate that attaching a verb to the construction family is determined partly by the prototypical qualities and partly by the effect of the constructions. For instance, the necessary features of the PMC construction family are +human arguments, social causation (or its subfield, competition, in the case of the defeat construction) and the malefactive theme argument, as well as the activity of the theme argument. The PMC reading is possible as long as these features are present.

As a result of the examination of the syntactic and idiosyncratic behaviour of these derivatives, I suggest that the relationship between different types of CSDs can be described as a network of prototype structures, functioning as a formation of lexical groupings within CSDs. This network of related prototypes and constructions is presented in Figure 1 below. The RSC construction is related to the PT2 structure; the PMC, the Emotive Causative Construction (Emotive CC in Figure 1) and the Perceptual Causative Construction occurring in connection with *haetuttaa* ‘make s.o. fetch’ and *etsityttää* ‘make s.o. search’ are comparable with the PT2.2 structure. The responsible SAD construction of *tapattaa* ‘make s.o. kill’ is in turn related to the PT1.1 structure. The outline in Figure 1 is not the ultimate depiction of CSDs; there may be subprototypes of the level from PT1.1. For instance, I have not included PMC subconstructions (see section 5.2.5). Also, further constructions related to social dominance and even new combinations may emerge, based on some of the prototype structures. Figure 1 describes CSD prototypes in the direction from the more general (PT) to the more specific. It cannot be ruled out that even more specific prototypes (PT1.1.1 etc.) are possible. The case of *tapattaa* ‘make s.o. kill’ represents the lexical level constructions. Prototypes PT1 and PT2 have the common structure PT, but differ in their argument structure.

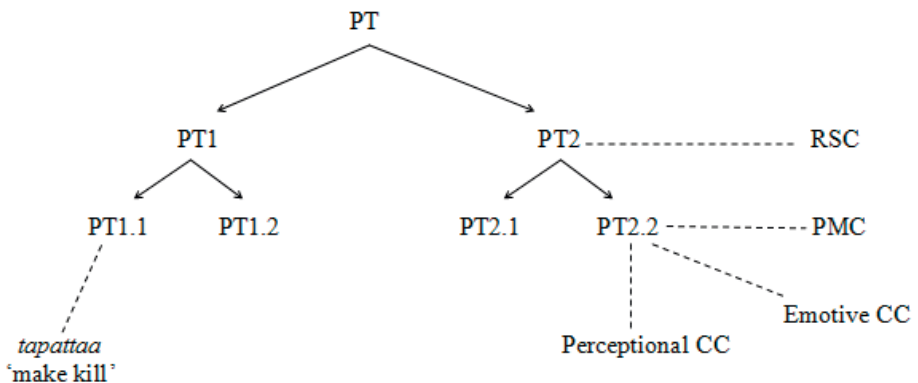

Figure 1. Prototypes and constructions

Figure 1 reflects the idea that the derivatives are not seen as a static lexical class but rather as lexemes with a varying ability to adapt to the defined (sub)prototypes or constructions. As was inferred in section 3.6 after the syntactic investigation of different types of CSDs, the defined prototypes cannot be seen as dividers of these derivatives into different classes, but rather as an explanation for the possibility of single CSDs occurring in different structural patterns. The verbs can thus change groups based on the constructions they form part of, and this ability is different in connection with different verbs.

What kind of relationship is there between prototypes and constructions? Prototypes represent the regular linking principles of CSDs on an abstract level, whereas constructions specify the particular syntactic and conceptual information. I suggest that CSD constructions can be seen as a factor behind verb groupings. The constructional patterns have an effect similar to analogy, by attracting the existing lexemes to behave within the limits of the construction. The question is: do the structures of constructions function as prototypes themselves i.e. are the constructions a type of prototype? If so, how are they related? Since the prototype structure also serves as a basic structure for construction, do they represent a part-whole relationship? What then is the independent meaning of the words in a CSD sentence? What are the prospective constructions for a CSD?

In this approach, the notion of prototype can be seen as a methodological tool, explicating the shared attributes of CSDs in the argument structure and linking connections. The constructions examined in this study are basically of two types: (i) constructions in a 'traditional' sense i.e. particular lexical-morphological form-meaning constellations; and (ii) interpretation constructions. The latter have received additional meaning components and, via interaction connected to specific attitudes, represent the outside observer's modality. What are the principal differences between prototypes and constructions? Although in this study both categories are built from the same 'bricks' of primitives and both can be said to function as an analogy, these notions have formally different status i.e. the prototypes represent a model of the described phenomena, whereas constructions depend on a fixed/irregular structure. The differences between prototypes and constructions can be summarized as follows:

<b>Prototype</b>	<b>Construction</b>
- a template to which concrete structures, expressions or constructions can be compared	- a specified structure into which appropriate linguistic material may be inserted; the concrete constructions can be compared to the prototypes
- a template of a reduced structure behind derivatives instantiating independent lexical units with certain common features	- may include specific syntactic, conceptual, pragmatic/ interactional elements; linkage to contextual information
- manifests both constant and variable features of the phenomenon in question	- manifests fixed features of a pattern

As a point of comparison for the relational configurations presented in Figure 1, consider the idea of metaconstruction and inheritance used within construction grammar. The notion of metaconstruction is introduced by Leino and Östman (2005: 206-207) to capture the analogical relationships within related constructions – “the systematic similarities and differences which occur between ‘several pairs of constructions’.” Metaconstruction is emphasized as standing for a generalization over construction while constructions stand for generalization over expressions. For a different view, based on a network of constructions with various combinations, see Petrova 2011. The consequence of this approach is that no construction in the network is given the status of metaconstruction.

The linking particularities in this study suggest that the connections and associations are not always straightforward. Whereas prototypes may be described via hierarchical relationships, as in Figure 1, constructions do not necessarily have a hierarchical relationship among themselves or in relation to prototypes. CSDs in turn may relate to the prototypes and constructions in a network-like manner. As analysis of *kyykittää* in section 5.2.4.2 suggests, even other aspects like idioms (*köyhät kyykkyy* ‘the poor into a squat’) could be included in the network. A CSD can shift the prototype structures and construction patterns it may adapt. The observations made on the basis of language use data suggest that the argument structure of CSDs does not follow directly on from verb structure but is additionally influenced by constructions. The reading of a verb can, for instance, be influenced by interpretative constructions like the PMC and RSC. The background hypothesis can be formulated so that in addition to regular linking (corresponding to the prototypes), there are closely related and more particularly defined constructions that contribute to the lexical arrangement. The constructions can be seen as the patterns determining the sorting of verbs into families, and the prototypes can explain the behaviour of the constructions. Recall for instance the case study of the verb *leikittää* ‘make

s.o. play’ in section 3.5; according to the linking configuration alternations of this verb, it can be related to the prototype-constructional network as illustrated in Figure 2:

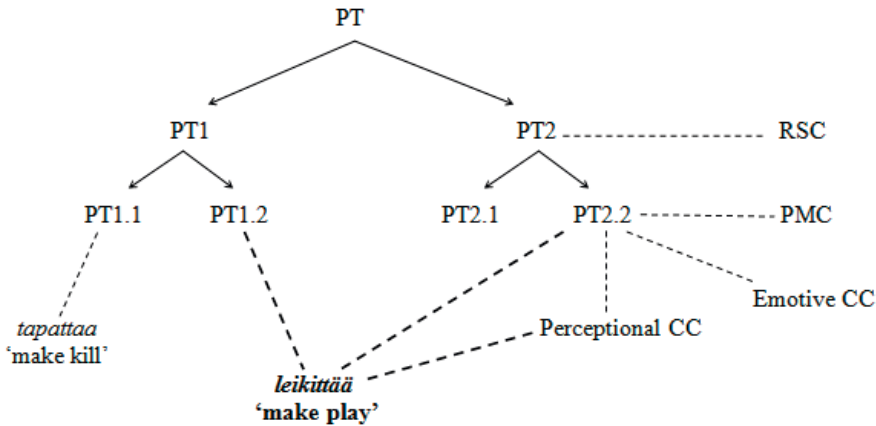
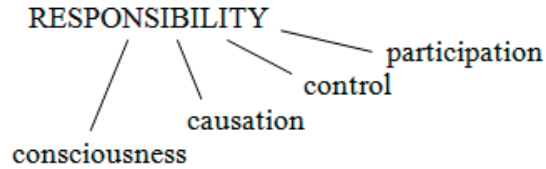

Figure 2. The verb *leikittää* ‘make s.o. play’ and the prototype-constructional approach

The constructions can be seen as an explanation for the observation that compositional productive derivation does not work when it comes to the use of causative verbs in Finnish. Causative verbs can have specialised uses where expressions of social relations and attitudes have important roles. In addition, when studying the patterns related to CSDs, we have seen that social hierarchies and dominance relations are manifested in the meaning and different uses of verbs. The social relations between the participants in events are encoded in the representation of social understanding. The building blocks of social understanding are the type of causation, agent properties (activity/passivity, dominance, control, consciousness, volitionality and responsibility), pragmatic implications via attitudes and certain perspectives on situations and interpretations. Thus, the malefactive reading of the SAR is connected to the speaker’s perspective and attitude: in the Power Misuse Construction reading, the speaker is accusing the SAD of making the SAR perform a meaningless activity. This reading does not imply that the SAR is aware of the power misuse; it is the speaker’s experience and claim. In my opinion, interpretation constructions open up aspects of interaction with the concept of responsible social activity and its function in constructions. Based on the discussion in this study, the following semantic aspects (as a minimum) are emphasized in responsible activity in language:



The prototype idea has proven to be a functional tool because it is not a result of regular word formation. The prototype structures employed in this study do not place requirements on the base verb, but rather represent the lexical properties of CSDs. The results of my examination suggest that the suffix *ttA* is a sign of lexical membership. This study confirms that derivation is a complex linguistic phenomenon with various aspects influencing the process: morphological, syntactic, semantic, constructional and analogical. The goal of this study was not to provide an exhaustive explanation of causatives of social dominance. I have examined different aspects of this verb group, with the result that these causatives are a dynamic and heterogeneous group of derivatives with cohesive as well as idiosyncratic features. It has turned out to be more natural to approach this phenomenon on its own premises, in order to discover the relationship between lexemes as well as the contextual and constructional effects. The degree of transparency of these verbs varies, and in practice the idiosyncrasy appears in different ways – as a result, the derivational and verb-specific senses often show a unique correlation. A contribution of this approach to the derivation system is the prospect of discovering the emergence of natural verb groupings and an attempt to account for the emergence of the clustering of verbs.

This study is not an exhaustive examination of all *ttA*-causatives expressing social relations. It has highlighted several avenues that should be investigated further. One is the linkage from social conceptualization to interaction and the development of interpretation constructions. Are there further constructions based on the social dimension, and do they correspond cross-linguistically? What are the rules of interpretation based on? The social interaction between the speaker and the listener(s) plays an important role: people talk about people and strive to outline the relevant elements in the assessment of situations based on social norms. In a simplified form, the behavior of people can be assessed on a scale from good to bad in respect of other people. Can social representation be regarded as a domain of its own? Another issue for future research is the testing of language intuition and the grammaticality of innovative derivations. What is the psychological status of prototypes? Does a novel CSD verb form part of the lexicon? This could perhaps be tested using semantic priming. And finally, an interesting area of research for the future is the textual function of the verbs, prototypes and constructions discussed in this study.



## Svensk sammanfattning

En väsentlig fråga inom lingvistiska såväl som kognitiva teorier är, hur språket beskriver kausala relationer. I finskan finns det förutom lexikala och analytiska medel en speciell typ av kausativa verb avledda med suffixet (*U*)*ttA* som används för att uttrycka att handlingen i fråga utförs av någon annan än subjektreferenten, t.ex. *Maija haetuttaa Matilla kirjastosta kirjan* 'Maija låter Matti hämta boken från biblioteket' och *Matti juoksuttaa Maijan kaupunkiin* 'Matti låter Maija springa till staden'.

Syftet med denna avhandling är att med exempel av den sociala dominansens kausativer undersöka ordbildningens natur samt begreppet 'socialt förorsakande'. Via den förra problemställningen strävar jag efter att fastställa hur kausativa avledningarna är relaterade med varandra. För att beskriva de gemensamma egenskaperna hos dessa verb använder jag avledningarnas prototypiska strukturer. Prototypen fungerar här som en abstrakt schablon som manifesterar den regelbundna argumentstrukturen samt kopplingen mellan syntaxen och semantiken. De särskilda och idiosynkratiska egenskaperna hos den sociala dominansens kausativer är definierade som konstruktioner. Konstruktionerna omfattar speciella syntaktiska och/eller semantiska element och utöver det också pragmatiska värderande implikationer i förhållande till den uttryckta situationen med en stark förbindelse till interaktionen. Resultaten av denna avhandling tyder på att förenlighet med olika konstruktioner och beroende av kontexten är karakteristiskt för den sociala dominansens kausativer.

Det sociala förorsakandet som ett koncept relaterat till den sociala dimensionen har en direkt förbindelse med undersökningsobjektet: detta begrepp syftar på situationen där en (typiskt mänsklig) aktör får en annan aktör att göra något. Uppbyggnaden av den sociala dimensionen i förbindelse med de undersökta kausativerna består av egenskaper förbundna med typen av förorsakande, argumentens agentiva egenskaper (aktivitet eller passivitet, dominans, kontroll, viljestyrighet och ansvarighet) samt pragmatiska implikationer, manifesterade genom konventionaliserade attityder och tolkningar. Ett exempel på en s.k. 'tolkningskonstruktion' är den negativa dominansens uttryck som jag kallar Maktmissbruks-konstruktionen (Power Misuse Construction) och som inkluderar en starkt kritisk hållning till den uttryckta situationen, t. ex. *Asiakas juoksuttaa lentoemäntää* 'Kunden låter flygvärdinnan springa'.

---

Metodologiskt har jag i denna avhandling kombinerat information baserad på det aktuella språkbruket och formell analys för att undersöka de forskningsfrågor som jag presenterade ovan. För att bättre förstå den sociala dominansens kausativer, var det ändamålsenligt att studera fenomenet via språkbruket. Jag har upprättat ett korpus med material från CSC:s databas Kielipankki samt material från Internet. Ett annat perspektiv ger resultatet av det test som jag har genomfört för att kartlägga språkbrukarnas tolkning av dessa verbs syntaktiska beteende och gestaltning av deras betydelse. På så sätt har jag kunnat variera satsomgivningarna samt de stilistiska parametrarna och fått ett tillräckligt representativt material. Det metodologiska verktyget i min avhandling är den konceptuella semantikens formalism, utvecklad av Jackendoff (1983, 1990, 1997), Nikanne (1990) och Pörn (2004). Jag har analyserat verbens samt konstruktionernas konceptuella lexikala struktur (conceptual lexical structure) och fastställt de prototypiska strukturerna med hjälp av den konceptuella semantikens verktyg. Teoretiskt sett var mitt mål att integrera den sociala dimension som de undersökta verben uttrycker i den konceptuella analysen och komplettera teoribildningen på detta område.

## References:

- Anttila, Raimo 1977. *Analogy*. Mouton, The Hague.
- Austin, John Langshaw 1962. *How to Do Things with Words*. Clarendon Press, Oxford.
- Björklund, Martina; Nikanne, Urpo & Virtanen, Tuija 2003. *Konstruktioistako herne nenään?* Presentation at XXX Kielitieteen päivät (linguistics conference) at the University of Joensuu, 15–16 May 2003.
- Cannelin, Knut 1931. Sanasyntyopin asema äidinkielen opetuksessa. *Virittäjä*, 186-195.
- Chomsky, Noam 1957. *Syntactic structures*. Mouton de Gruyter.
- Chomsky, Noam 1965. *Aspects of the theory of syntax*. MIT Press, Cambridge, MA.
- Chomsky, Noam 1972. Remarks on Nominalizations. In *Studies on semantics in generative grammar* (11-61), Noam Chomsky. The Hague, Mouton.
- Chomsky, Noam 1986. *Knowledge of language: its nature, origin, and use*. New York, Praeger.
- Chomsky, Noam 1995. *The minimalist program*. The MIT Press, Cambridge.
- Crystal, David 2001. *Language and the Internet*. Cambridge University Press, Cambridge.
- Croft, William 1993. Case marking and the semantics of mental verbs. In *Semantics and the Lexicon* (55-72), James Pustejovsky (ed.). Kluwer Academic Publishers, Dordrecht.
- Croft, William 1998. The Structure of Events and the Structure of Language. In *The new psychology of language: cognitive and functional approaches to language structure* (67-92), Michael Tomasello (ed.). Lawrence Erlbaum Associates, Mahwah, New Jersey.
- Croft, William 2001. *Radical Construction Grammar: Syntactic Theory in Typological Perspective*. Oxford University Press, Oxford.
- Culicover, Peter W. & Jackendoff, Ray 1995. Something Else for the Binding Theory. *Linguistic Inquiry* Vol. 26, 249-275.
- Dixon, Robert M. W. 2000. A typology of causative: form, syntax and meaning. In *Changing Valency: Case Studies in Transitivity* (30-79), Robert M. W. Dixon & Alexandra Y. Aikhenvald (eds.). Cambridge University Press, Cambridge.
- Dowty, David 1991. Thematic Proto-Roles and Argument Selection. *Language* 67, 547-619.
- Fillmore, Charles J. 1968. The case for case. In *Universals in linguistic theory* (1-88), Emmon Bach & Robert T. Harms (eds.). Holt, Rinehart & Winston, New York.
- Fillmore, Charles J. 1988. The mechanisms of 'Construction Grammar'. *Berkeley Linguistic Society* 14, 35-55.

- Fillmore, Charles J. 1999. Inversion and constructional inheritance. In *Lexical and constructional aspects of linguistic explanation* (113-128), Gert Webelhuth, Jean-Pierre Koenig & Andreas Kathol (eds.). CSLI, Stanford.
- Fillmore, Charles J., Kay, Paul & O'Connor, Catherine 1988. Regularity and Idiomaticity in Grammatical Constructions: The Case of *Let Alone*. *Language* 64, 501-538.
- Flint, Aili 1980. *Semantic structure in the Finnish lexicon: verbs of possibility and sufficiency*. SKST 360. Finnish Literature Society, Helsinki.
- Fodor, Jerry 1975. *The Language of Thought*. New York, Crowell.
- Fodor, Jerry 1983. *The modularity of mind: An essay on faculty psychology*. MIT Press, Cambridge, MA.
- Foley, William, A. & van Valin, Robert D. 1984. *Functional syntax and universal grammar*. Cambridge University Press, Cambridge.
- Geeraerts, Dirk 1989. Prospects and problems of prototype theory. *Linguistics* 27, 587-612.
- Gibbs, Raymond W. 2006. *Embodiment and Cognitive Science*. Cambridge University Press, Cambridge.
- Givón, Talmy 1974. *Cause and control: on the semantics of interpersonal manipulation*. Indiana University Linguistics Club, Bloomington.
- Goldberg, Adele 1995. *Constructions*. University of Chicago Press, Chicago.
- Goldberg, Adele 2006. *Constructions at Work: The Nature of Generalization in Language*. Oxford University Press, Oxford.
- Grice, H. Paul 1975. Logic and conversation. In *Speech acts* [Syntax and semantics, Vol.3.], (41-58), Peter Cole & Jerry L. Morgan (eds.). Academic Press, London.
- Gruber, Jeffrey 1965. *Studies in lexical relations*. Massachusetts Institute of Technology. Dept. of Modern Languages. Thesis Ph.D.: <http://dspace.mit.edu/handle/1721.1/13010> (downloaded on 13 September 2010.)
- Gruber, Jeffrey 1970. *Studies in lexical relations*. Indiana University Linguistics Club. Bloomington, Indiana.
- Hakulinen, Auli & Karlsson, Fred 1979. *Nyky-suomen lauseoppi*. Finnish Literature Society, Helsinki.
- Hakulinen, Lauri 1979. *Suomen kielen rakenne ja kehitys*. Otava, Helsinki.
- Halle, Morris & Marantz, Alec 1993. Distributed Morphology and the Pieces of Inflection. In *The View from Building 20: Essays in Linguistics in Honor of Sylvain Bromberger* (111-176), Kenneth Hale & Samuel J. Keyser (eds.). MIT Press, Cambridge, MA.
- Halliday, Michael A. K. 1967. *Intonation and grammar in British English*. Mouton, The Hague.
- Herlin, Ilona 1998. *Suomen kun*. Finnish Literature Society, Helsinki.

Hoffmann, Sebastian 2007. Processing Internet-derived Text – Creating a corpus of Usenet Messages. *Literary and Linguistic Computing* 22/2, 151-165.

Hopper, Paul J. & Thompson Sandra A. 1980. Transitivity in grammar and discourse. *Language* 56, 251-299.

ISK = *Iso suomen kielioppi* (The Big Finnish Reference Grammar). Hakulinen, Auli; Vilkuna, Maria; Korhonen, Riitta; Koivisto, Vesa; Heinonen, Tarja Riitta & Alho, Irja 2004. Finnish Literature Society, Helsinki.

Itkonen, Esa 2005. *Analogy as Structure and Process: Approaches in Linguistics, Cognitive Psychology and Philosophy of Science*. John Benjamins Publishing Company, Amsterdam.

Itkonen, Esa 2006. Three fallacies that recur in linguistic argumentation. In *Papers on Language Theory* (122–126), Timo Haukioja (ed.). University of Turku, Publications in General Linguistics 10, Turku.

Jackendoff, Ray 1972. *Semantic interpretation in generative grammar*. MIT Press, Cambridge, MA.

Jackendoff, Ray 1975. Morphological and semantic regularities in the lexicon. *Language* 59, 639-671.

Jackendoff, Ray 1983. *Semantics and Cognition*. MIT Press, Cambridge, MA.

Jackendoff, Ray 1985. Multiple Subcategorizations and the  $\theta$ -Criterion: the Case of Climb. *Natural Language and Linguistic Theory* 3, 271-295.

Jackendoff, Ray 1987. The status of thematic relations in the linguistic theory. *Linguistic Inquiry* 18, 369-411.

Jackendoff, Ray 1990. *Semantic structures*. MIT Press, Cambridge, MA.

Jackendoff, Ray 1991. Parts and boundaries. *Cognition* 41, 9-45.

Jackendoff, Ray 1992a. *Languages of the mind: essays on mental representation*. Massachusetts Institute of Technology

Jackendoff, Ray 1992b. Mme. Tussaud meets the binding theory. *Natural Language and Linguistic Theory* 10, 1-31.

Jackendoff, Ray 1997. *The architecture of the language faculty*. MIT Press, Cambridge, MA.

Jackendoff, Ray 2003. *Foundations of language: brain, meaning, grammar, evolution*. Originally published 2002. Oxford University Press, Oxford.

Jackendoff, Ray 2007. *Language, consciousness, culture: essays on mental structure*. MIT Press, Cambridge, MA.

Jääskeläinen, Petri 2004. *Instrumentatiivisuus ja nykysuomen verbinjohto. Semanttinen tutkimus*. University of Jyväskylä, Jyväskylä.

Kainlauri, Tero 2005. The illative case in Finnish: a force dynamic or a directional marker? Talk given at the 21<sup>st</sup> Scandinavian Conference of Linguistics at the Norwegian University of Science and Technology (2 June 2005).

Kangasmaa-Minn, Eeva 1977. Verbien piiloderivaatiosta. *Sananjalka* 19, 5-25.

Kangasmaa-Minn, Eeva 1981. Derivaatiopuun putonnaiset. *Sananmuodostuksen ongelmia*. Suomen kielitieteellisen yhdistyksen julkaisuja, Turku.

Kangasmaa-Minn, Eeva 1994. Derivaatio kielellisenä prosessina ('Form and Function in Derivation'). *Sananjalka* 36, 37-43.

Karlsson, Fred 1983. *Suomen kielen äänne- ja muotorakenne*. WSOY, Juva.

Kay, Paul 1995. Construction Grammar. In *Handbook of Pragmatics. Manual* (171-177), Jef Verschueren, Jan-Ola Östman & Jan Blommaert (eds.). Amsterdam & Philadelphia, John Benjamins.

Kay, Paul & Fillmore, Charles J. 1999. Grammatical constructions and linguistic generalizations: The *What's X doing Y?* construction. *Language* 75, 1-33.

Kytömäki, Leena 1977. *Suomen verbijohdosten generointia*. Lisensiaatintyö. Suomen kieli, Turun yliopisto.

Kytömäki, Leena 1978. Kuratiivikausatiivit. *Rakenteita*. Juhlakirja Osmo Ikolan 60-vuotispäiväksi 6. 2. 1978 (129-150). Turun yliopiston suomalaisen ja yleisen kielitieteen laitoksen julkaisuja 6. Turku.

Kytömäki, Leena 1989. Teettoverbit: johdon ja taivutuksen välimaastoa. *Sananjalka* 31, 61-79. Suomen kielen seuran vuosikirja. Turku.

Kytömäki, Leena 1991. Mikä on johdosten paikka (English summary: The place and status of derivatives). *Sananjalka* 33, 7-29. Miscellany of the Department of Finnish and General Linguistics of the University of Turku. Offprint.

Kytömäki, Leena 1992. *Suomen verbiderivaation kuvaaminen 1600-luvulta nykypäiviin*. Turku.

Labov, William 1973. The boundaries of words and their meanings. In *New Ways of Analyzing Variation in English* (340-373), Charles-James Bailey, Roger Shuy (eds.). Georgetown University Press, Washington, D.C.

Lakoff, George 1987. *Women, fire, and dangerous things: what categories reveal about the mind*. University of Chicago Press, Chicago.

Langacker, Ronald 1987. *Foundations of cognitive grammar*. Vol. 1. *Theoretical prerequisites*. Stanford University Press, Stanford.

Langacker, Ronald 1991. *Concept, Image and Symbol: the cognitive basis of grammar*. Mouton de Gruyter, Berlin.

Leino, Jaakko 2003. *Antaa sen muuttua. Suomen kielen permissiivirakenne ja sen kehitys*. Finnish Literature Society, Helsinki.

Leino, Jaakko & Östman, Jan-Ola 2005. Constructions and variability. In *Grammatical constructions: back to the roots* [Constructional Approaches to Language 4] (191-213), Mirjam Fried, Hans Boas (eds.). John Benjamins, Amsterdam.

Leino, Pentti 1991. *Lauseet ja tilanteet. Suomen objektin ongelmia*. Finnish Literature Society, Helsinki.

Leino, Pentti 2001. Verbit, konstruktiot ja lausetyypit. In *Roolit ja rakenteet. Henkilöviitein allatiivi Biblian verbikonstruktioissa* (11-66). Finnish Literature Society, Helsinki.

Leiwo, Matti 1985. Syyttämisen ja moittimisen pragmatiikkaa ja semantiikkaa. In *Lauseita ja ajatuksia*. Suomen kielen laitos, Åbo Akademi, Turku.

Levin, Beth 1993. *English verb classes and alternations: a preliminary investigation*. The University of Chicago Press, Chicago.

Levin, Beth & Rappaport Hovav, Malka 1992. The Lexical Semantics of Verbs of Motion: The Perspective from Unaccusativity. In *Thematic Structure: Its role in Grammar* (247-269), Iggy Roca (ed.). Mouton de Gruyter, Berlin.

Levinson, Stephen C. 2003. *Space in Language and Cognition: explorations in cognitive diversity*. Cambridge University Press, Cambridge.

Lyons, John 1968. *Introduction to theoretical linguistics*. Cambridge University Press, Cambridge.

Länsimäki Maija 1987. *Suomen verbikantaiset in:ime -johdokset*. Finnish Literature Society, Helsinki.

Maling, Joan 1993. Of Nominative and Accusative: the Hierarchical Assignment of Grammatical Cases in Finnish. In *Case and other functional categories in Finnish syntax* (51-76), Anders Holmberg and Urpo Nikanne (eds.). Mouton de Gruyter, Berlin, New York.

Nikanne, Urpo 1990. *Zones and Tiers*. Finnish Literature Society, Helsinki.

Nikanne, Urpo 1994. Notes on movement to the Spec (IP) position in Finnish. In *Studies on scrambling: movement and non-movement approaches to free word-order phenomena* (431-457), Norbert Corver & Henk van Riemsdijk (eds.). Mouton de Gruyter, Berlin, New York.

Nikanne, Urpo 1995. Action Tier formation and Argument Linking. *Studia Linguistica* 49, 1-32.

Nikanne, Urpo 1997a. Locative Case Adjuncts in Finnish: Notes on Syntacto-Semantic Interface. *Nordic Journal of Linguistics* 20, 155-178.

Nikanne, Urpo 1997b. Suomen infiniittisten adjunktien temporaalinen tulkinta. *Virittäjä* 3, 338-357.

Nikanne, Urpo 1997c. Lexical Conceptual Structure and Syntactic Arguments. *SKY Journal of Linguistics* 10, 81-118.

Nikanne, Urpo 1998a. The Lexicon and Conceptual Structure. *Papers from the 16<sup>th</sup> Scandinavian Conference on Linguistics* (305-319), Timo Haukioja (ed.). Turun yliopiston suomalaisen ja yleisen kielitieteen laitoksen julkaisuja, Turku.

Nikanne, Urpo 1998b. Semanttiset roolit. In *Kiinnostuksesta kieleen*, *Fennistica* 13 (127-143). Åbo kademin Suomen kielen laitos, Turku.

Nikanne, Urpo 2002. *Kerrokset ja kytkenät* ('Tiers and links'): <http://www.abo.fi/fak/fin/kurssit/KONSEM/> (downloaded on 18 November 2010).

Nikanne, Urpo 2005. Constructions in conceptual semantics. In *Construction grammars: cognitive grounding and theoretical extensions* (191-242), Jan-Ola Östman, Mirjam Fried (eds). John Benjamins, Amsterdam.

Nikanne, Urpo 2006. Aspectual case marking of object in Finnish. *Research in Language* 4, 215-242.

Nikanne, Urpo 2008. Conceptual semantics. In *Handbook of Pragmatics*, Jan-Ola Östman and Jef Verschueren in collaboration with Eline Versluys. John Benjamins, Amsterdam.

Nenonen, Marja 2007. Unique, but not cranberries: idiomatic isolates in Finnish. In *Collocations and Idioms 1. Papers from the First Nordic Conference on Syntactic Freezes, Joensuu, 19–20 May 2006*, Marja Nenonen & Sinikka Niemi (eds.). Studies in Languages 41. University of Joensuu, Joensuu.

Östman, Jan-Ola & Fried, Mirjam 2004. Historical and intellectual background of Construction Grammar. In *Construction Grammar in a Cross-Language Perspective* (1-10), Mirjam Fried (ed.). In series: Constructional approaches to language, vol. 2. John Benjamins, Amsterdam.

Östman, Jan-Ola & Fried, Mirjam (eds.) 2005. *Construction grammars: cognitive grounding and theoretical extensions*. John Benjamins, Amsterdam.

Pajunen, Anneli 1988. *Verbien leksikaalinen kuvaus*. Helsingin yliopisto, Helsinki.

Pajunen, Anneli 2001. *Argumenttirakenne. Asiantilojen luokitus ja verbien käyttäytyminen suomen kielessä*. Finnish Literature Society, Helsinki.

Paulsen, Geda 2004. *Kuka tekee mitäkin? Kuratiivikausatiivit kielenkäyttäjien näkökulmasta* ('Who does what? Curative causatives from language users' perspective'). Master's thesis. Åbo akademi.

Paulsen, Geda 2005a. Features of causative deverbal verbs with motion verbs as their bases. Talk given at the 21<sup>st</sup> Scandinavian Conference on Linguistics at the Norwegian University of Science and Technology (2 June 2005).

Paulsen, Geda 2005b. 'Bossy' causative verbs in Finnish: Power abuse and social attitudes lexicalized in the derived causative verbs. A presentation given in Workshop on Spatial Language and Dialogue at Bremen University (24 October 2005).

Pennanen, Esko 1984. Havaintoja suomen teettoverbeistä. *Virittäjä* 88, 431–443.

Penttilä, Aarni 1957. *Suomen kielioppi*. WSOY, Porvoo.

Petrova, Oksana 2007. Phraseological component isolation in computer-mediated discourse: a formal approach. In *Collocations and Idioms 1. Papers*



from the First Nordic Conference on Syntactic Freezes (269-281), Marja Nenonen & Sinikka Niemi (eds.). Studies in Languages 41. University of Joensuu, Joensuu.

Petrova, Oksana 2009. Negative Modality in Finnish Phraseological Units. In *Phraseologie disziplinar und interdisziplinär* (237-251), Csaba Földes (ed.). Gunter Narr verlag, Tübingen.

Petrova, Oksana 2010. Computer-Mediated Discourse vs. Traditional Text Corpora as a Data Source for Idiom Variation Research in Finnish. In *Computergestützte und korpusbasierte Methoden in der Phraseologie, Phraseografie und der Lexikografie*, Stefaniya Ptashnyk, Erla Hallsteinsdottir, Noah Bubenhofer (eds.). Schneider Verlag Hohengehren, Baltmannsweiler.

Petrova, Oksana 2011. 'About Pearls and Pigs' Conceptual-semantic Tiernet approach to formal representation of structure and variation of phraseological units. A PhD study, Åbo Akademi.

Pinker Steven 1989. *Learnability and cognition: the acquisition of verb-argument structure*. Harvard University Press, Cambridge, MA.

Pörn, Michaela 2001. Valinnaisesti ja pakollisesti kausatiiviset tunnekausatiivit ja niiden argumenttirakenne. *Puhe ja kieli* 3, 115-128.

Pörn, Michaela 2004. *Suomen tunnekausatiiviverbit ja niiden lausemaisiet täydennykset*. Finnish Literature Society, Helsinki.

Pörn, Michaela 2007. Causative Spatial Expressions in Finnish and Swedish. *SKY Journal of Linguistics* 20, 345-366.

Rosch, Eleanor 1978. Principles of categorization. In *Cognition and categorization* (27-48), Eleanor Rosch & Barbara B. Lloyd (eds.). Hillsdale, Lawrence Erlbaum, New York.

Räisänen, Alpo 1988. *Suomen kielen u-johtimiset verbit*. Finnish Literature Society, Helsinki.

Räisänen, Alpo 1983. Kantasanan ja johdoksen suhteesta. In *Nykysuomen rakenne ja kehitys* (112-137), Auli Hakulinen & Pentti Leino (eds.). Tietolipas 93. Finnish Literature Society, Helsinki.

Räisänen, Alpo 1979. Segmentaation ongelmasta suomen kielen johtopissa. *Virittäjä* 83, 167-178.

Saussure, Ferdinand de 1966. *Course in general linguistics*. Bally, Charles & Sechehaye, Albert (eds.). McGraw-Hill Paperback Edition, New York. (First published in 1915 as *Cours de Linguistique Générale*. Paris, Pyot.)

Schippan, Thea 1984. *Lexicologie der deutschen Gegenwart-sprache*. Leipzig.

Shibatani, Masayoshi 1976. The Grammar of Causative Constructions: A Conspectus. In *The grammar of Causative Constructions* (43-116), Masayoshi Shibatani (ed.). Syntax and Semantics, Vol. 6. Academic Press, New York.

Shibatani, Masayoshi 2002. Some basic issues in the grammar of causation. In *The Grammar of Causation and Interpersonal Manipulation* (1-

22), Masayoshi Shibatani (ed.). John Benjamins Publishing Company, Amsterdam.

Shibatani, Masayoshi & Pardeshi, Prashant 2002. The causative continuum. In *The Grammar of Causation and Interpersonal Manipulation* (85-126), Shibatani, Masayoshi (ed.). John Benjamins Publishing Company, Amsterdam.

Siironen, Mari 2001. *Kuka pelkää, ketä pelottaa. Nykysuomen tunneverbien kielioppia ja semantiikkaa*. Finnish Literature Society, Helsinki.

Siitonen, Kirsti 1999. *Agenttia etsimässä: U-verbijohdokset edistyneen suomenoppijan ongelmana*. Turun yliopiston suomalaisen ja yleisen kielitieteen laitoksen julkaisuja, Turku.

Siro, Paavo 1996. *Lauseopin periaatteita: kaksitoista artikkelia*. Pentti Leino (ed.). Helsingin yliopiston suomen kielen laitos, Helsinki.

Siro, Paavo 1964. *Suomen kielen lauseoppi*. Tietosanakirja, Helsinki.

Sperber, Dan & Wilson, Deidre 1986. *Relevance: communication and cognition*. Blackwell, Oxford.

Talmy, Leonard 1976. Semantic Causative Types. In *The grammar of Causative Constructions* (43-116), Masayoshi Shibatani (ed.). Syntax and Semantics. Vol. 6. Academic Press, New York.

Talmy, Leonard 1988. Force dynamics in language and cognition. *Cognitive science* 12, 49-100.

Taylor, John R. 1989. *Linguistic categorization: Prototypes in linguistic theory*. Clarendon Press, Oxford.

Tenny, Carol 1994. *Aspectual roles and the syntax-semantic interface*. Kluwer, Dordrecht.

Toivainen, Jorma 1993. The Nature of the Accusative in Finnish. In *Case and other functional categories in Finnish syntax* (111-128), Anders Holmberg and Urpo Nikanne (eds.). Mouton de Gruyter, Berlin, New York.

Tomasello, Michael 1999. *The cultural origins of human cognition*. Harvard University Press, Cambridge.

Tuomikoski, Risto 1978. Objektinsijaisista määrän adverbialaaleista, ('On object-cased adverbials of amount'), *Virittäjä* 82, 26-51.

Vainikka, Anne 1993. The Three Structural Cases in Finnish. In *Case and other functional categories in Finnish syntax* (129-159), Anders Holmberg & Urpo Nikanne (eds.). Mouton de Gruyter, Berlin, New York.

Vendler, Zeno 1967. Verbs and times. *Linguistics in Philosophy*. Cornell University Press, Ithaca, London.

Vilkuna Maria 1992. *Referenssi ja määräisyys suomenkielisten tekstien tulkinnassa*. Finnish Literature Society, Helsinki.

Vilkuna Maria 1996. *Suomen lauseopin perusteet*. Kotimaisten kielten tutkimuskeskuksen julkaisuja 90. Edita, Helsinki.

Wierzbicka, Anna 1996. *Semantics: primes and universals*. Oxford University press, Oxford.

Wiik, Kalevi 1972. *Suomen akkusatiiviobjektin muoto*. Turun yliopiston fonetiikan laitoksen julkaisuja 12, Turku.

Zee, Emile van der & Nikanne, Urpo 2000. Introducing cognitive interfaces and constraints on linking cognitive information. In *Cognitive interfaces: Constraints on linking cognitive information* (1-17), Emile van der Zee & Urpo Nikanne (eds.). Oxford University Press, Oxford.

### **Corpus material source:**

The Finnish Language Text Collection (Suomen kielen tekstikokoelma) from the Language Bank of Finland (<http://www.csc.fi/kielipankki/>), developed by CSC, the Finnish IT centre for science (Tieteen tietotekniikan keskus).

### **Dictionaries:**

KS = Kielitoimiston sanakirja 'The New Dictionary of Modern Finnish' parts 1–3, electronic dictionary 2004 (<http://mot.kielikone.fi>). Kotimaisten kielten tutkimuskeskuksen julkaisuja 140. Kotimaisten kielten tutkimuskeskus, Helsinki 2006.

NS = *Nyky-suomen sanakirja I-IV* [The Dictionary of Modern Finnish]. 3<sup>rd</sup> edition (1970). WSOY, Porvoo 1951-1961.

SKE = Suomen kielen etymologinen sanakirja 'The Etymological Dictionary of Finnish'. Finnish Literature Society, Helsinki 1983.

Suomen murteiden sanakirja 'The Dictionary of Finnish Dialects'. Kotimaisten kielten tutkimuskeskus: Valtion painatuskeskus, Helsinki 1985.

Urbaani Sanakirja 'The urban dictionary' electronic dictionary available online at <http://www.urbaanisanakirja.com/index.php>.

## Abbreviations and symbols

/	the slash stands for the possibility of alternatives
< >	these brackets stand for the option nature of a notion
{ }	these brackets stand for the mutually exclusive relation to different positions in the LCS
1sg	1 <sup>st</sup> person singular
2sg	2 <sup>nd</sup> person singular
3sg	3 <sup>rd</sup> person singular
1pl	1 <sup>st</sup> person plural
2pl	2 <sup>nd</sup> person plural
3pl	3 <sup>rd</sup> person plural
abl	ablative case ('from')
acc	accusative
ade	adessive case ('on' & 'at')
all	allative case ('onto' & 'towards')
ARB	the arbitrary argument
AT	T-tier of adjunct
CS↓	matrix sentence causes adjunct's situation ('leads to')
CS↑	adjunct structure causes situation in matrix sentence ('because of')
CSD	Causatives of Social Dominance
CT-tier	constructional T-tier
Aver	average value
b	feature [bounded]
D	directionality node
ECC	Emotive Causative Construction
ela	elative case ('from')
inch	inchoative derivative verb suffix
freq	frequentative derivative verb suffix
gen	genitive case
gl	feature [goal]
ill	illative case ('to' & 'into')
inf	infinitive marker
inf1	infinitive marker <i>tA</i>
inf2	infinitive marker <i>te</i>
inf3	infinitive marker <i>mA</i>
LCS	lexical conceptual structure
MT	T-tier of matrix sentence
nom	nominative case
neg	negation element
OAR	object argument of root verb
OARobj	OAR in object position in both accusative & partitive case

OARacc	OAR in object position in accusative case
OARpart	OAR in object position in partitive case
ORadj	optional object or adjunct of root verb in object place
part	partitive case
past	past tense
ptc	participle
pl	plural
PMC	Power Misuse Construction
px	possessive suffix
RESADJ	resultative adjunct
RSC	Responsibility Shift Construction
ro	feature [route]
SAD	Subject argument of the derived causative verb
SAR	Subject argument of the root verb
SARade	SAR adjunct in adessive case
SARobj	SAR in object position
so	feature [source]
TP	test person
T	time-node
SD	standard deviation
Z1	zone 1 (location zone)
Z2	zone 2 (thematic zone)
Z3	zone 3 (causative zone)
X	T-tier of adjunct
Y	T-tier of matrix sentence

## Appendix 1

Miten luontevilta seuraavat lauseet mielestäsi tuntuvat? Merkitse rasti asteikkoon tuntemuksesi mukaan sopivaan kohtaan (0 = täysin mahdoton; 10 = täysin luonteva). Kirjoita sama asia toisin sanoin lauseen alla olevalle viivalle. Silloinkin, kun lause on outo, sano, miten tulkitisit sen. Sano myös, jos et ymmärrä lausetta lainkaan. Kiitos avusta!

- |   |                |
|---|----------------|
| 1) Matti ompeluttaa Pekalla puvun/pukua | 0   .....   10 |
| 2) Matti jonotuttaa Pekkaa.             | 0   .....   10 |
| 3) Matti ompeluttaa Pekan komeaksi.     | 0   .....   10 |
| 4) Matti syötättää Pekan.               | 0   .....   10 |
| 5) Matti jonotuttaa tunnin.             | 0   .....   10 |
| 6) Matti syötättää Pekalla puuron.      | 0   .....   10 |
| 7) Matti ompeluttaa puvun               | 0   .....   10 |
| 8) Matti jonotuttaa Pekalla tunnin      | 0   .....   10 |
| 9) Matti ompeluttaa Pekan.              | 0   .....   10 |
| 10) Matti syötättää Pekalla.            | 0   .....   10 |
| 11) Matti jonotuttaa Pekan uuvuksiin    | 0   .....   10 |
| 12) Matti syötättää puuron.             | 0   .....   10 |
| 13) Matti jonotuttaa Pekan.             | 0   .....   10 |
| 14) Matti ompeluttaa Pekalla.           | 0   .....   10 |
| 15) Matti syötättää Pekkaa.             | 0   .....   10 |
| 16) Matti jonotuttaa Pekalla.           | 0   .....   10 |
| 17) Matti ompeluttaa Pekkaa             | 0   .....   10 |
| 18) Matti syötättää Pekan kylläiseksi.  | 0   .....   10 |





## Causation and social dimension in language

The analysis of social causation accounts for both language and cognition, explaining how the perception and categorization of reality is represented in grammar and lexicon. The focus of present study is on the derived causative verbs in Finnish that typically express an event involving two active human participants, one of whom makes the other one do something. The questions of control, activity and perspective on the situation expressing social relations are addressed within the conceptual semantics theoretical framework. The analysis is based on a two prototype model of the causative derivatives. The prototypes are used for describing the similarities and differences between the causative verbs of social dominance.

Åbo Akademi University Press  
ISBN 978-951-765-556-9

